

## METHOD 1330A

### EXTRACTION PROCEDURE FOR OILY WASTES

#### 1.0 SCOPE AND APPLICATION

1.1 Method 1330 is used to determine the mobile metal concentration (MMC) in oily wastes.

1.2 Method 1330 is applicable to API separator sludges, rag oils, slop oil emulsions, and other oil wastes derived from petroleum refining.

#### 2.0 SUMMARY OF METHOD

2.1 The sample is separated into solid and liquid components by filtration.

2.2 The solid phase is placed in a Soxhlet extractor, charged with tetrahydrofuran, and extracted. The THF is removed, the extractor is then charged with toluene, and the sample is reextracted.

2.3 The EP method (Method 1310) is run on the dry solid residue.

2.4 The original liquid, combined extracts, and EP leachate are analyzed for the EP metals.

#### 3.0 INTERFERENCES

3.1 Matrix interferences will be coextracted from the sample. The extent of these interferences will vary considerably from waste to waste, depending on the nature and diversity of the particular refinery waste being analyzed.

#### 4.0 APPARATUS AND MATERIALS

4.1 Soxhlet extraction apparatus.

4.2 Vacuum pump or other source of vacuum.

4.3 Buchner funnel 12.

4.4 Electric heating mantle.

4.5 Paper extraction thimble.

4.6 Filter paper.

4.7 Muslin cloth disks.

4.8 Evaporative flask - 250-mL.

4.9 Balance - Analytical, capable of weighing to  $\pm 0.5$  mg.

## 5.0 REAGENTS

5.1 Reagent grade chemicals shall be used in all tests. Unless otherwise indicated, it is intended that all reagents shall conform to the specifications of the Committee on Analytical Reagents of the American Chemical Society, where such specifications are available. Other grades may be used, provided it is first ascertained that the reagent is of sufficiently high purity to permit its use without lessening the accuracy of the determination.

5.2 Reagent water. All references to water in this method refer to reagent water, as defined in Chapter One.

5.3 Tetrahydrofuran,  $C_4H_8O$ .

5.4 Toluene,  $C_6H_5CH_3$ .

## 6.0 SAMPLE COLLECTION, PRESERVATION, AND HANDLING

6.1 Samples must be collected in glass containers having a total volume of at least 150 mL. No solid material should interfere with sealing the sample container.

6.2 Sampling devices should be wiped clean with paper towels or absorbent cloth, rinsed with a small amount of hexane followed by acetone rinse, and dried between samples. Alternatively, samples can be taken with disposable sampling devices in beakers.

## 7.0 PROCEDURE

7.1 Separate the sample (minimum 100 g) into its solid and liquid components. The liquid component is defined as that portion of the sample which passes through a  $0.45\ \mu\text{m}$  filter media under a pressure differential of 75 psi.

7.2 Determine the quantity of liquid (mL) and the concentration of the toxicants of concern in the liquid phase (mg/L).

7.3 Place the solid phase into a Soxhlet extractor, charge the concentration flask with 300 mL tetrahydrofuran, and extract for 3 hours.

7.4 Remove the flask containing tetrahydrofuran and replace it with one containing 300 mL toluene.

7.5 Extract the solid a second time, for 3 hours, with the toluene.

7.6 Combine the tetrahydrofuran and toluene extracts.

7.7 Analyze the combined extracts for the toxicants of concern.

7.8 Determine the quantity of liquid (mL) and the concentration of the toxicants of concern in the combined extracts (mg/L).

7.9 Take the solid material remaining in the Soxhlet thimble and dry it at 100°C for 30 minutes.

7.10 Run the EP (Method 1310) on the dried solid.

7.11 Calculate the mobile metal concentration (MMC) in mg/L using the following formula:

$$\text{MMC} = 1,000 \times \frac{(Q_1 + Q_2 + Q_3)}{(L_1 + L_2 + L_3)}$$

where:

$Q_1$  = Mass of toxicant in initial liquid phase of sample (amount of liquid x concentration of toxicant) (mg).

$Q_2$  = Mass of toxicant in combined organic extracts of sample (amount of liquid x concentration of toxicant) (mg).

$Q_3$  = Mass of toxicant in EP extract of solid (amount of extract x concentration of toxicant) (mg).

$L_1$  = Volume of initial liquid (mL).

$L_2$  = Volume of liquid in THF and toluene extract (Step 7.8) (mL).

$L_3$  = Volume of liquid in EP (mL) = 20 x [weight of dried solid from Step 7.9 (g)].

## 8.0 QUALITY CONTROL

8.1 Any reagent blanks or replicates samples should be subjected to exactly the same analytical procedures as those used on actual samples.

8.2 Refer to Chapter One for specific quality control procedures.

## 9.0 METHOD PERFORMANCE

9.1 No data provided.

## 10.0 REFERENCES

1. Rohrbough, W.G.; et al. Reagent Chemicals, American Chemical Society Specifications, 7th ed.; American Chemical Society: Washington, DC, 1986.

2. 1985 Annual Book of ASTM Standards, Vol. 11.01; "Standard Specification for Reagent Water"; ASTM: Philadelphia, PA, 1985; D1193-77.

Figure 1. Extractor

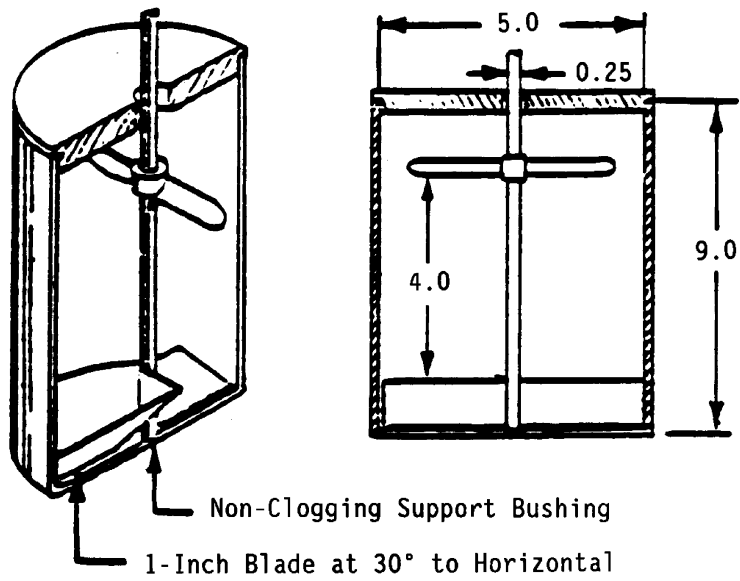

Figure 2. Rotary Extractor

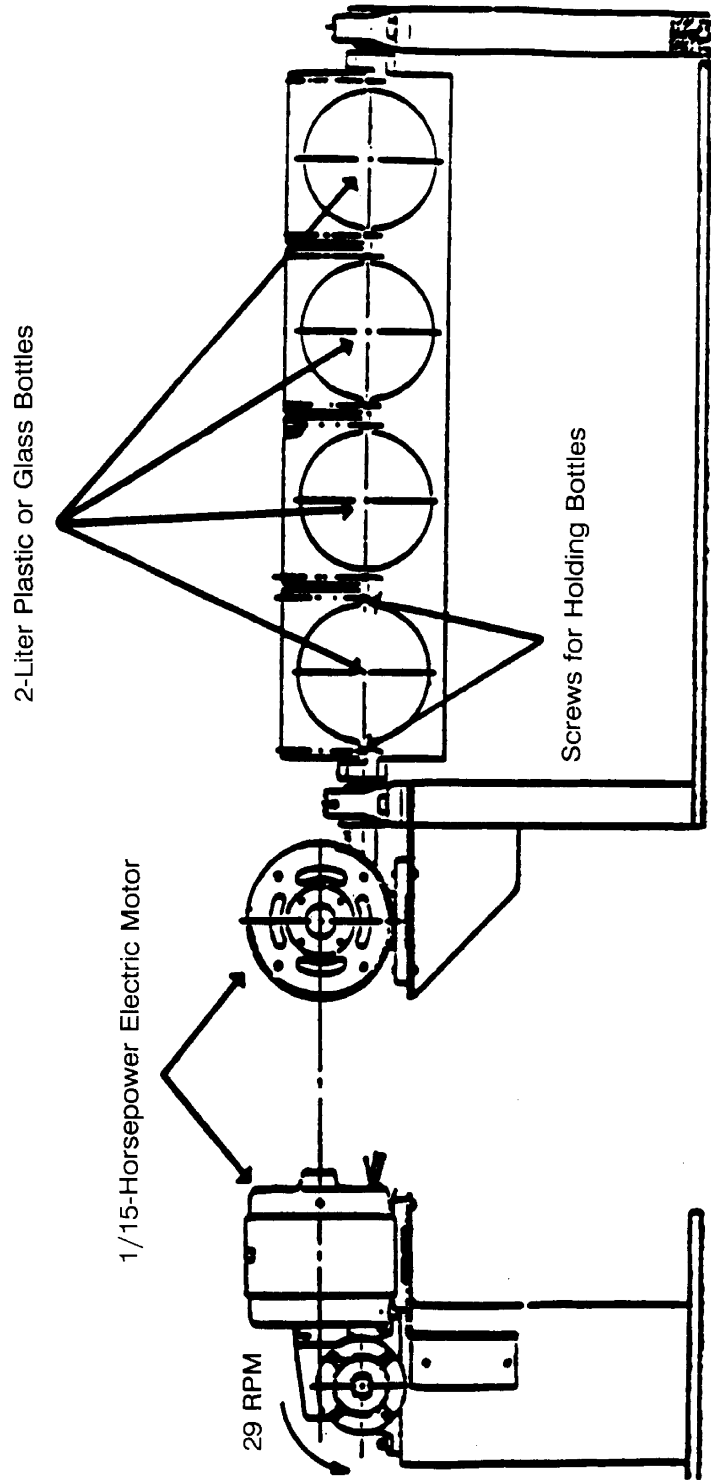

Figure 3. EPRI Extractor

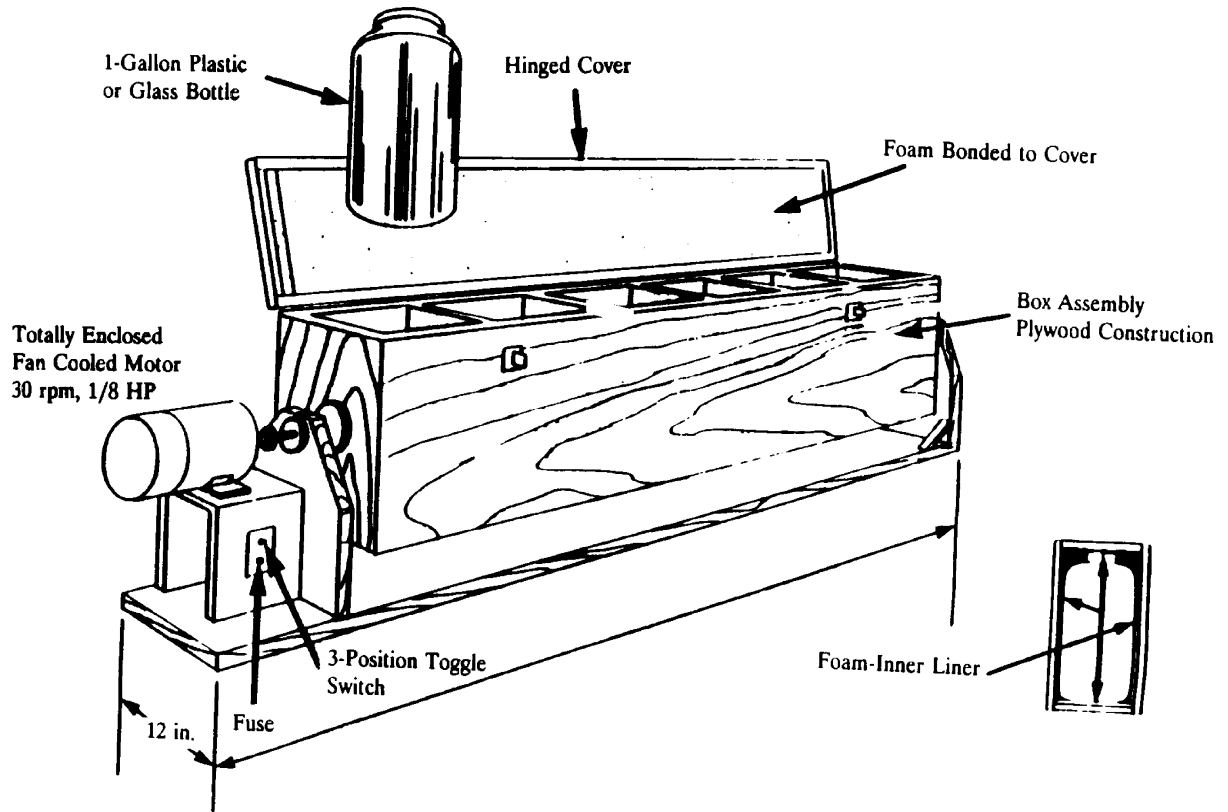
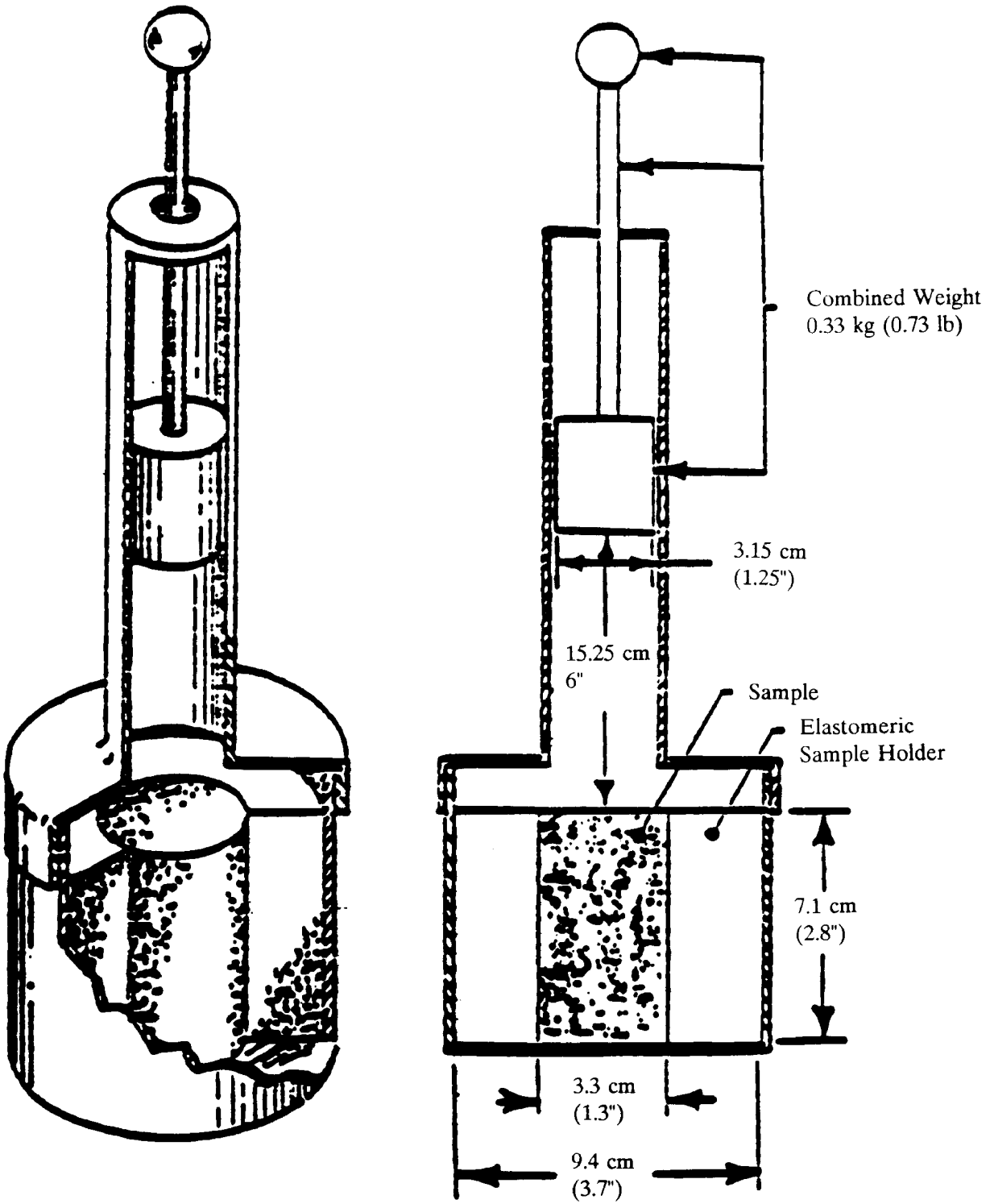

Figure 4. Compaction Tester





METHOD 1330A  
EXTRACTION PROCEDURE FOR OILY WASTE

