



AECOM
303 E. Wacker Drive, Suite 900
Chicago, Illinois 60601

312-938-0300 tel
312-938-1109 fax

October 4, 2013

Ms. Michele Pisterzi
AT&T Illinois
2427 Union Street
Blue Island, Illinois 60406

RE: Radiological Survey of Right-of-Way Utility Excavation
Permit No.: 375593475
Permit Address: 630-631 N. McClurg Ct.
AECOM Project No. 60163572

Dear Ms. Pisterzi:

Pursuant to conditions specified in a permit (attached) issued by the City of Chicago, radiation monitoring was required to be performed at the above referenced site. AECOM Technical Services, Inc. (AECOM) provided the required radiation monitoring on September 24 and 25, 2013 for a trench excavation to install a telephone communications service package.

Surveying was conducted in 18-inch lifts for soils removed from an approximately 3-foot wide by 37-foot long trench excavation to a depth of 36-inches in the Right of Way (ROW) near the intersection of East Ontario Street and North McClurg Court (refer to annotated drawing), required for the installation of a telephone communications service package. The monitoring revealed no indication of soils above the specified cleanup value established by the U.S. Environmental Protection Agency (USEPA) for the Streeterville area of Chicago. The USEPA cleanup value for Chicago's Streeterville area is 7.1 picocuries per gram (pCi/g) total radium (Ra-226 + Ra-228).

Gamma radiation count measurements for the project were made using a Ludlum Model 2221 survey meter and an unshielded 2 x 2 inch sodium iodide (NaI) probe Model 44-10. For the instrument used, the gamma count indicative of the USEPA 7.1 pCi/g cleanup value was 17,920 counts per minute (cpm) unshielded. Thus, gamma readings above 17,920 cpm would be considered a potential indication of the presence of radiologically contaminated fill soil.

The field gamma background for the area was measured at approximately 7,900 cpm unshielded. Field gamma measurements greater than twice the background represent potential anomalous results that require more cautious and frequent field screening, but are not necessarily indications of the presence of thorium contaminated fill soil.

The field gamma measurements within the excavation and the spoil materials generated during the excavation process did not exceed the field instrument threshold equivalent to the USEPA cleanup value and ranged from a minimum of 7,500 cpm to a maximum of 15,800 cpm unshielded. Thus, there was no indication of the presence of radiologically-contaminated fill soil and/or an exceedance of the USEPA cleanup value of 7.1 pCi/g total radium.

As part of the permit conditions this letter has been forwarded to:

Chicago Department of Public Health
Attn: Ms. Rahmat Begum
333 South State Street, Rm. 200
Chicago, Illinois 60604

Radiological Survey of Right-of-Way Utility Excavation
Permit No.: 375593475
Page 2

Please contact us with any questions you have regarding this letter or the reported results.

Regards,



Brian R. Schmidt
Project Scientist II



Steven C. Kornder, Ph.D.
Senior Project Geoscientist

cc: Rahmat Begum, Chicago Department of Public Health
Verneta Simon, USEPA

Attachments: Permit
Sketch
AT&T Drawing

Permit # 375593475

AMENDED



Received Date: Sep 12, 2013 5:20:13

SBC ILLINOIS

2427 UNION

BLUE ISLAND, IL 60406

MICHELE 708-824-2817

**City of Chicago
Department of Transportation
(312) 744-4652**

ACTIVITY HOURS

Start no earlier than 9 AM. Stop no later than 4 PM. - Street Opening (Curb Lane & Traffic Lane)

DATES

Sep 12, 2013 through Oct 12, 2013

ACTIVITIES

Street Opening (Curb Lane & Traffic Lane):

Dig #: TBD

There will be 1 opening(s) in the public way for the purpose: INTERCEPT DUCT PKG.

8 Feet x 4 Feet x 5 Feet

Excavation may commence on - NO SOONER.

629 N MCCLURG CT

DAS PROJECT

ALSO MH ACCESS IN C/T LANE & INTERSECTION (APPROX 75' AT WORK LOCATION AS IT MOVES ALONG)

RESTORATION: TO CDOT STANDARDS / CITY OF CHICAGO AGREEMENT EFF 8/2010 FOR THIS PROJECT

CONTRACTOR: SBC / WESTERN UTILITY
JOB NO# IL4663 / APPL NO# 2013-1031

PLEASE NOTE: WE WILL BE REMOVING EXISTING DAS EQPT FROM

Street Opening (Curb Lane & Traffic Lane):

Dig #: TBD

POLE @ 362 E. ONTARIO AND ATTACHING TO THE NEW POLE @ 629-631 N MCCLURG CT THAT IS BEING PLACED BY POWER CONSTRUCTION - THEY ARE WORKING ON THE HOSPITAL RENOVATION PROJECT. ATT/ WESTERN WILL NOT BE DIGGING AT THE NEW POLE LOCATION. WE WILL BE NEEDING PARKING FOR ROOM TO WORK AT THAT LOCATION.

OK TO RELEASE PE RAHMAT BEGUM ON 9/16/13
400 - 400 E ONTARIO ST

Street Opening (Intersection):

Dig #: TBD

There will be 1 opening(s) in the public way for the purpose: INTERCEPT DUCT PKG.

8 Feet x 4 Feet x 5 Feet

Excavation may commence on - NO SOONER.

629 - 629 N MCCLURG CT

400 - 400 E ONTARIO ST

Parking Work Vehicle - Maint (Curb-Traffic Lane):

Dig #: TBD

A WORK VEHICLE - C/T & INTERSECTION vehicle will be using 75 feet in the Curb and Traffic Lanes for Maintenance.

Vehicle License Number N/A and State issued NA.

621 - 631 N MCCLURG CT

362 - 401 E ONTARIO ST

Restrictions:

1. A copy of the permit must remain on-site for inspector's review.

Restrictions:

2. Permit fees must be paid within 24 hours of the date of issuance. Failure to pay will result in you being considered in violation of the terms and agreement of the permit and subject to any applicable fine and fees as if you never attained a permit. Additionally, you will still be responsible for the cost of the original permit. Monthly billing accounts are not applicable to the 24 hour payment criteria but failure to pay the monthly bill by the due date will result in the same penalties applying.
3. All directional boring must be pre-approved by the Office of Underground Coordination.
4. Contractor must secure plating over all openings in the roadway and secure all sidewalk/parkway openings during non-working hours until such time when the road surface is restored.
5. All traffic control will be the responsibility of the contractor and must comply with all MUTCD standards.
6. Restore all lanes to normal operation during non-working hours.
7. Must use flagmen and/or arrow boards to maintain traffic operations through the work zone.
8. Contractor must notify DIGGER at 312-744-7000 no less than 48 hours (exclusive of Saturdays, Sundays and Holidays) but no more than 14 calendar days in advance of the start of the excavation or demolition, unless the excavation date was provided with the application and remains unchanged. Prior to 26 calendar days the Contractor must notify DIGGER to renew the dig date!
9. It is the Excavator's responsibility to request refreshing of marks when needed, but no longer than 28 calendar days after the last requested date.
10. When applicable, all excavation areas are to be clearly marked in safety white paint prior to calling DIGGER. White paint is not required for joint meets or emergency work.
11. Excavators requesting dig tickets are responsible for the protection of utility markings at the job site. Any markings of underground utilities utilizing utility colors, must be done by facility owners or authorized agents only.
12. Use of pneumatic equipment must not begin before 8:00 A.M. or continue after 8:00 P.M.
13. Permittee must provide a sign which identifies the telephone number and company or person performing the work. Signage may be affixed to barricades.
14. Permanent base pavement restoration to follow within 5 days after the completion of underground work.
15. All pavements and pavement markings are to be restored in accordance with CDOT Construction Standards.
16. All street openings must be restored with concrete base to grade.
17. Work to be performed as per plans and specifications.
18. Streets recently resurfaced must be restored to proper standards (resurface to nearest 1/4 pt, see CDOT Construction Standards for further details).
19. WARNING: THIS WORKSITE(S) CONTAINS RADIOACTIVE MATERIAL. ANY QUESTIONS PERTAINING TO HANDLING OF MATERIALS, CONTACT THE DEPT. OF ENVIRONMENT AT 312-744-3152.
20. Contractors to post signs to indicate: BIKE LANE CLOSED - SHARED LANE YIELD TO BIKES.

Restrictions:

It is also the permit holder's responsibility to restore to original condition any damage to any bikeway, including replacement pavement markings and signage. You must contact Ben Gomberg (312) 744-8093 48 hours in advance of any activity.

21. No work in or use of the public right of way is to be done when a special event is taking place. It is up to the applicant to determine if an event is scheduled. To obtain a listing of programs or events within the City of Chicago please dial 311 when you are within the City boundaries.
22. It is the responsibility of the applicant to fund Traffic Control Aides if the City deems it necessary due to heavy congestion situations.
23. Pursuit to City Ordinances 10-20-150 and 10-28-281.3 a re-inspection fee of \$100 may be assessed for each inspection conducted after the initial inspection.
24. All metal plates used for public way construction or placed within the right-of-way must indicate Ownership!
25. Maintain vehicular traffic at all times.
26. Maintain pedestrian traffic at all times.
27. Cranes must be operated by a licensed crane operator.
28. Work area to be backfilled to grade or plated when site is unattended.
29. Restoration to follow immediately upon completion of underground work. Weather permitting. (If excavating)

Affected CUAN Sites: 7, 15, 21, 22, 24, 28, 29, 34, 36, 38, 53, 61, 68, 70, 141, 147

EFFECTIVE DATES OF PERMIT

Current: Sep 12, 2013 through Oct 12, 2013 (Input date: Sep 12, 2013 5:20:13 p.m.)

END OF PERMIT

JOB TITLE AT+T ROW Utility Installation 630-31 N. McCaughey
 JOB NO. 60163572 T. 9100 CALCULATION NO. _____
 ORIGINATOR BRIAN SCHMIDT DATE 9/24-25/2013
 REVIEWER BRIAN SCHMIDT DATE 9/24-25/2013
 SCALE N/A SHEET NO. 1 OF 1

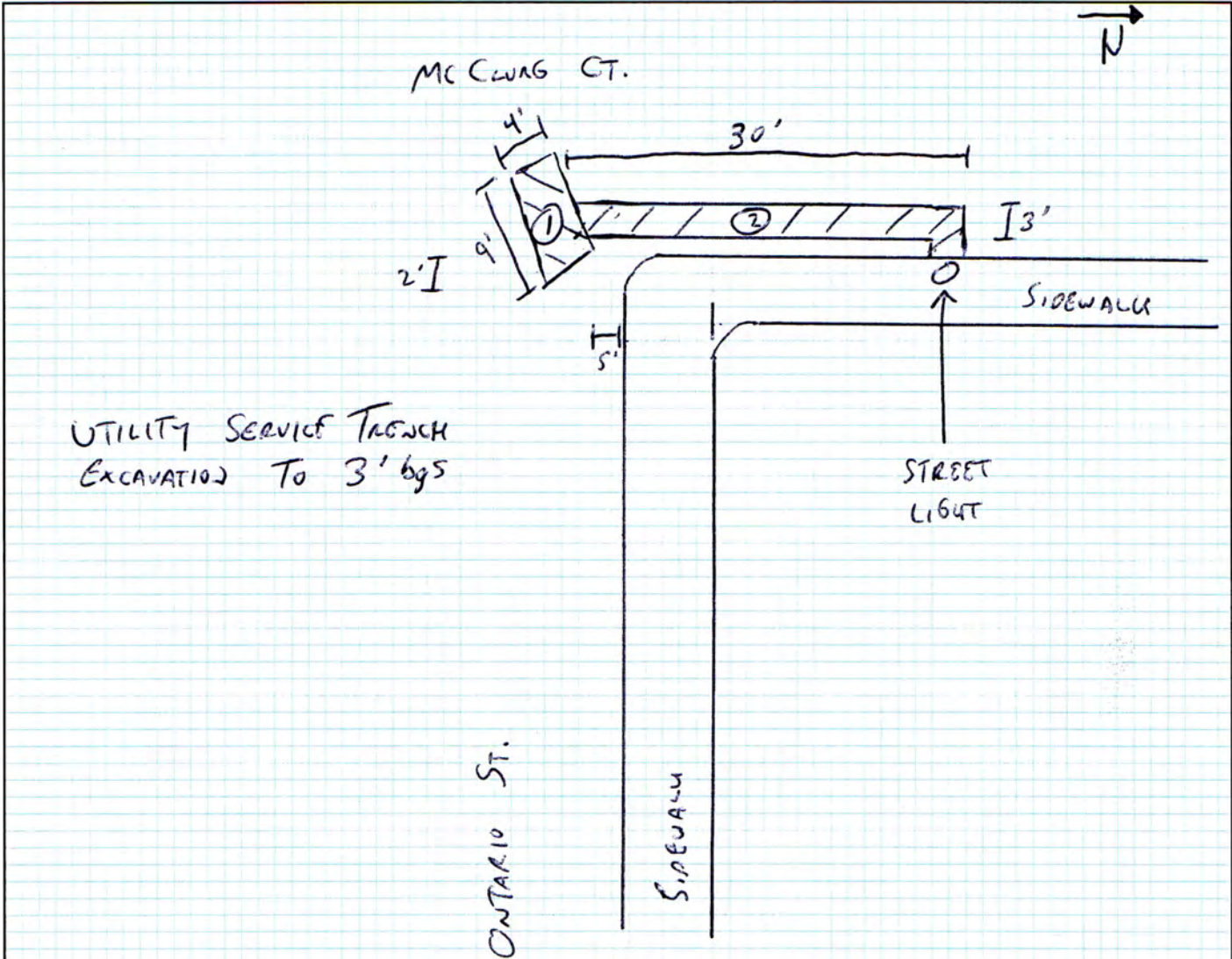

UTILITY SERVICE TRENCH
EXCAVATION TO 3' bgs

9' x 4' x 36"

①	DEPTH	CPM
	0-12"	CONCRETE
	12-30"	7500
	30-48"	9300
	36-54"	9100

30' x 3' x 36"

②	DEPTH	CPM
	0-12"	CONCRETE
	12-30"	10,100
	30-48"	11300
	36-54"	15800

SURVEYED w/ A Ludlum - 2221 w/ 2x2 NAI Probe
(UNSHIELDED) - S/N 176944

BACKGROUND VALUE = 7900 CPM (1 MINUTE COUNT)

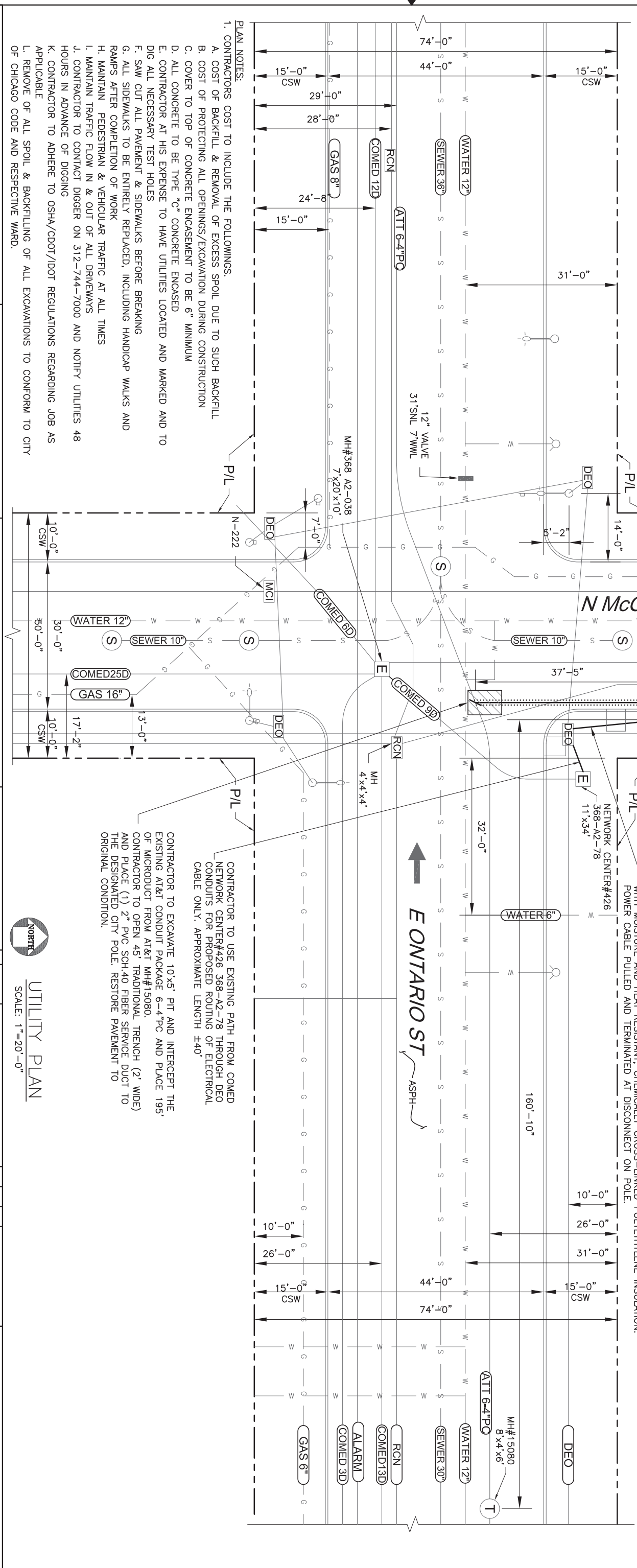
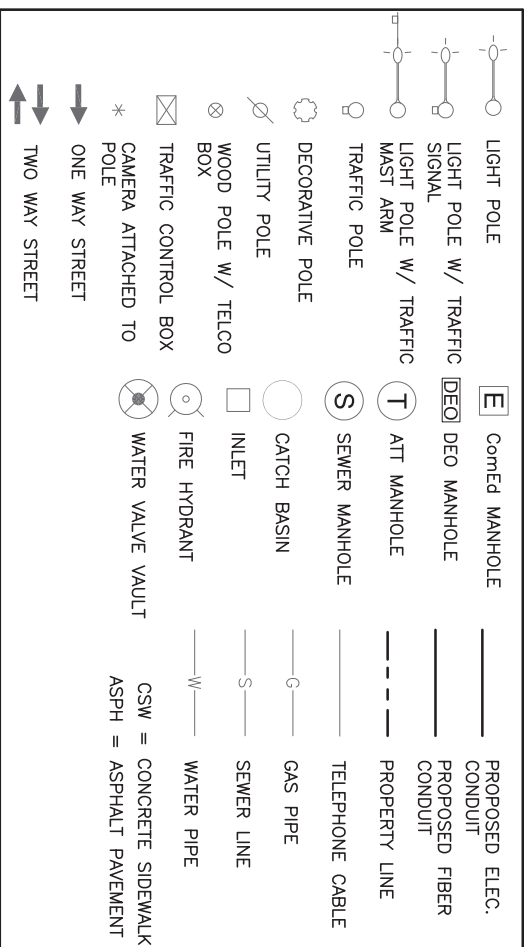

NOTE:
COLOR OF NEW LIGHT/TRAFFIC POLE TO MATCH EXISTING.

EXISTING TRAFFIC/LIGHT POLE & FOUNDATION TO BE REMOVED & REPLACED WITH:

FOUNDATION: EXISTING POLE FOUNDATION TO BE REMOVED & REPLACED W/ NEW 30"x11'-0" WITH 1-1/2" ANCHOR RODS ON EXACT SAME POLE LOCATION. REFER CITY OF CHICAGO DEPARTMENT OF TRANSPORTATION DIVISION OF ELECTRICAL OPERATIONS DRAWING #817. SEE SHEET S01.

LIGHT POLE: REPLACE EXISTING POLE WITH STEEL, 3/4"-6" LONG, POLE BASE 12.5" DIAMETER 3GA THK. REFER CITY OF CHICAGO DEPARTMENT OF TRANSPORTATION DIVISION OF ELECTRICAL OPERATIONS DRAWING #827.

REINSTALL OR REPLACE NEW MAST ARMS, SIGNS, TRAFFIC SIGNAL HARDWARE AND INSTALL NEW 8' LUMINAIRES 400W H.P.S.V. AS PER CITY STANDARDS.

TYPE OF POLE: ~~TRAFFIC~~ OR LIGHT IS THE POLE DECORATIVE? YES OR ~~NO~~

OTHER EQUIPMENT ALREADY INSTALLED ON POLE? YES OR ~~NO~~

BASE OF POLE - BALLAST HOUSING? YES OR ~~NO~~

SIDE WALK VAULTED? YES OR ~~NO~~

NEAREST BLDG ADDRESS: 633 N McClurg Ct, CHICAGO, IL 60611

COLOR OF POLE: GREEN

CONTRACTOR TO PLACE 70' (2) #2 AWG SINGLE COPPER CONDUCTORS, STRANDED, INSULATED WITH MOISTURE AND HEAT RESISTANT, CHEMICALLY CROSS-LINKED POLYETHYLENE INSULATION. POWER CABLE PULLED AND TERMINATED AT DISCONNECT ON POLE.

CONTRACTOR TO USE EXISTING PATH FROM COMED NETWORK CENTER#426 368-A2-78 THROUGH DEO CONDUITS FOR PROPOSED ROUTING OF ELECTRICAL CABLE ONLY. APPROXIMATE LENGTH ±40'

CONTRACTOR TO EXCAVATE 10'x5' PIT AND INTERCEPT THE EXISTING AT&T CONDUIT PACKAGE 6-4"PC AND PLACE 195' OF MICRODUCT FROM AT&T MH#15080. CONTRACTOR TO OPEN 45' TRADITIONAL TRENCH (2' WIDE) AND PLACE (1) 2" PVC SCH.40 FIBER SERVICE DUCT TO THE DESIGNATED CITY POLE. RESTORE PAVEMENT TO ORIGINAL CONDITION.

- PLAN NOTES:**
- CONTRACTORS COST TO INCLUDE THE FOLLOWINGS:
 - COST OF BACKFILL & REMOVAL OF EXCESS SPOIL DUE TO SUCH BACKFILL
 - COST OF PROTECTING ALL OPENINGS/EXCAVATION DURING CONSTRUCTION
 - COVER TO TOP OF CONCRETE ENCASEMENT TO BE 6" MINIMUM
 - ALL CONCRETE TO BE TYPE "C" CONCRETE ENCASED
 - CONTRACTOR AT HIS EXPENSE TO HAVE UTILITIES LOCATED AND MARKED AND TO DIG ALL NECESSARY TEST HOLES
 - SAW CUT ALL PAVEMENT & SIDEWALKS BEFORE BREAKING
 - ALL SIDEWALKS TO BE ENTIRELY REPLACED, INCLUDING HANDICAP WALKS AND RAMPS AFTER COMPLETION OF WORK
 - MAINTAIN PEDESTRIAN & VEHICULAR TRAFFIC AT ALL TIMES
 - MAINTAIN TRAFFIC FLOW IN & OUT OF ALL DRIVEWAYS
 - CONTRACTOR TO CONTACT DIGGER ON 312-744-7000 AND NOTIFY UTILITIES 48 HOURS IN ADVANCE OF DIGGING
 - CONTRACTOR TO ADHERE TO OSHA/CDOT/IDOT REGULATIONS REGARDING JOB AS APPLICABLE
 - REMOVE OF ALL SPOIL & BACKFILLING OF ALL EXCAVATIONS TO CONFORM TO CITY OF CHICAGO CODE AND RESPECTIVE WARD.

UTILITY PLAN
SCALE: 1"=20'-0"

Apex Engineers, Inc.
Structural & Civil Engineers
500 E. 22nd STREET
LOMBARD, Illinois 60148
Ph. (630) 627-1800
Fax. (630) 627-1165
APEX JOB No.AT11-001-22

SITE NAME: ONTARIO ST & McCLURG CT
DAS #: IL4663
633 N McClurg CT
CHICAGO, IL 60611

at&t
Mobility
930 NATIONAL PARKWAY
SCHLAUBURG, IL 60173

NO.	DATE	ISSUED FOR CONSTRUCTION	BY	CHK	APP'D
0	08/08/13	ISSUED FOR CONSTRUCTION	GR	RG	RG
SCALE: AS SHOWN		DESIGNED BY:	DRAWN BY:		

at&t
UTILITY PLAN
JOB NUMBER: _____
SCOPE: _____
DRAWING NUMBER: IL4663-02
REV: _____