

**SAMPLING AND ANALYSIS PLAN/QUALITY ASSURANCE
PROJECT PLAN
FOR
GOLD KING MINE RELEASE
SILVERTON, SAN JUAN COUNTY, COLORADO**

Prepared for
UNITED STATES ENVIRONMENTAL PROTECTION AGENCY

Region 8
1595 Wynkoop Street
Denver, CO 80202

Prepared by
WESTON SOLUTIONS, INC.
1435 Garrison Street, Suite 100
Lakewood, CO 80215

Contract No.: EP-S8-13-01
Technical Direction Document No.: 1508-04, 1509-02

September 2015

SAP/QAPP Revision Log

Project: Gold King Mine Blowout

Task Monitors: Craig Myers/Steve Way

Technical Direction Document (TDD): 0001/1508-04 and 0001/1509-02

Date	Revision Number	Reason for Change of Scope/Procedures	SAP Section Superseded
8/10/15	Addendum 1	Add residential water sampling	N/A
8/10/15	Addendum 2	Add sediment sampling	N/A
8/11/15	Addendum 3	Add surface soil sampling	N/A
8/20/15	Addendum 4	Add biological sampling	N/A

TABLE OF CONTENTS

Title	Page
EXECUTIVE SUMMARY	vi
Introduction	1
Worksheet 1 & 2 — Title and Approval Page	4
Worksheet 3 & 5 — Project Organization and QAPP Distribution	5
Worksheet 4, 7 & 8 — Personnel Qualifications	6
Worksheet 6 — Communication Pathways	9
Worksheet 9 — Project Planning Session Summary	11
Worksheet 10 — Conceptual Site Model	12
Worksheet 11 — Project/Data Quality Objectives	14
Worksheet 12 — Measurement Performance Criteria Tables	16
Worksheet 13 — Secondary Data Uses and Limitations	17
Worksheet 14 & 16 — Project Tasks & Schedule	19
Worksheet 15 — Project Action Limits and Laboratory-Specific Detection/Quantitation Limits	21
Worksheet 17 — Sampling Design and Rationale	29
Worksheet 18 — Sampling Locations and Methods	33
Worksheet 19 & 30 — Sample Containers, Preservation, and Hold Times	34
Worksheet 20 — Field Quality Control Sample Summary	35
Worksheet 21 — Field SOPs	36
Worksheet 22 — Field Equipment Calibration, Maintenance, Testing, and Inspection	38
Worksheet 23 — Analytical SOPs	40
Worksheet 24 — Analytical Instrument Calibration	42
Worksheet 25 — Analytical Instrument and Equipment Maintenance, Testing, and Inspection ..	44
Worksheet 26 & 27 — Sample Handling, Custody, and Disposal	45
Worksheet 28 — Analytical Quality Control and Corrective Action	46
Worksheet 29 — Project Documents and Records	47
Worksheet 31, 32 & 33 — Assessments and Corrective Action	50
Worksheet 34 — Data Verification and Validation Inputs	51
Worksheet 35 — Data Verification Procedures	53
Worksheet 36 — Data Validation Procedures	55
Worksheet 37 — Data Usability Assessment	57

LIST OF APPENDICES

Title	
Appendix A	EPA Region 8 QA Document Review Crosswalk
Appendix B	Site Specific Data Management Plan

LIST OF ACRONYMS

°C	degrees Celsius
%D	percent difference
%R	percent recovery
%RSD	percent relative standard deviation
ACM	asbestos containing material
AES	Atomic Emission Spectrometry
ANSI	American National Standards Institute
APP	Accident Prevention Plan
ARAR	applicable or relevant and appropriate requirements
ASQ	American Society for Quality
AST	aboveground storage tank
B	bias
CA	Corrective Action
CB	calibration blank
CCB	continuing calibration blank
CCV	continuing calibration verification
CERCLA	Comprehensive Environmental Response, Compensation, and Liability Act
CHMM	Certified Hazardous Materials Manager
CLP	Contract Laboratory Program
cpm	counts per minute
CO	Contracting Officer
COC	Chain-of-Custody
COR	Contracting Officer Representative
Cr+6	Hexavalent Chromium
CRL	Central Regional Laboratory
CRQL	Contract Required Quantitation Limits
CSM	Conceptual Site Model
CVAA	Cold Vapor Atomic Absorption
D	absolute range
DMP/BMP	Region 8 Data Management Plan/Best Management Practices
DQI	Data Quality Indicator
DQO	Data Quality Objective
EDD	electronic data deliverable
EDX	Energy Dispersive X-Ray
ERM	Emergency Response Manager
ERT	Environmental Response Team
ESI	Expanded Site Inspection
FID	Flame Ionization Detector
FS	Feasibility Study
FSP	Field Sampling Plan
GC	gas chromatography
GC/MS	gas chromatography/mass spectrometry
GIS	Geographic Information System
HASP	Health and Safety Plan
HRGC/HRMS	high resolution gas chromatography/high resolution mass spectrometry
HRGC/LRMS	high resolution gas chromatography/low resolution mass spectrometry
HRS	Hazard Ranking System
HPLC	high performance liquid chromatography
ICB	initial calibration blank

LIST OF ACRONYMS

ICP	inductively coupled plasma
IDW	investigation-derived waste
ISTD	Instrument Standard
ITRC	Interstate Technology and Regulatory Council
LBP	lead based paint
LCS	laboratory control sample
LOD	limit of detection
LOQ	limit of quantitation
MDL	method detection limit
mg/kg	milligrams per kilogram
MPC	Measurement Performance Criteria
MS	matrix spike
MSD	matrix spike duplicate
NA	not applicable
NCP	National Contingency Plan
ND	non-detect
NIOSH	National Institute of Occupational Safety and Health
NPL	National Priorities List
NRCS	Natural Resource Conservation Service
PA	Preliminary Assessment
PAH	Polycyclic Aromatic Hydrocarbons
PAL	Project Action Limit
PCB	Polychlorinated biphenyls
PCDD	Polychlorinated Dibenzo-P-Dioxins
PCDF	Polychlorinated Dibenzofurans
PCM	Phase Contrast Microscopy
P.E.	Professional Engineer
PID	Photoionization Detector
PLM	polarized light microscopy
PM	Project Manager
PMP	Project Management Professional
POC	Point of Contact
PQL	Project Quantitation Limit
PQO	Project Quality Objectives
PT	proficiency testing
PTL	Project Team Lead
PUF	polyurethane foam
QA	quality assurance
QAPP	Quality Assurance Project Plan
QC	quality control
QMP	Quality Management Plan
Ra	Radium
RA	Risk Assessment
RAS	Routine Analytical Services
RCRA	Resource Conservation and Recovery Act
RI	Remedial Investigation
RL	reporting limit
RM	Removal Manager

LIST OF ACRONYMS

RML	Removal Management Levels
RPD	relative percent difference
RSD	relative standard deviation
RSL	regional screening levels
SAP	Sampling and Analysis Plan
SAS	Special Analytical Services
SCDM	Superfund Chemical Data Matrix
SI	Site Inspection
SOP	Standard Operating Procedure
SRM	Standard Reference Material
SSDMP	Site-Specific Data Management Plan
SSL	soil screening level
START IV	Superfund Technical Assessment and Response Team 4
SVOC	Semi-volatile Organic Compounds
TAL	Target Analyte List
TBD	to-be-determined
TCL	Target Compound List
TDD	Technical Direction Document
TEM	transmission electron microscopy
TSA	Technical Systems Audit
UFP-QAPP	Uniform Federal Policy–Quality Assurance Project Plan
USACE	United States Army Corps of Engineers
USDA	United States Department of Agriculture
U.S. EPA	United States Environmental Protection Agency
USGS	United States Department of the Interior Geologic Survey
UST	underground storage tank
VOC	Volatile Organic Compounds
WAM	Work Assignment Manager
WESTON	Weston Solutions, Inc.
XRD	x-ray diffraction
XRF	X-Ray Fluorescence

EXECUTIVE SUMMARY

PROBLEM STATEMENT

The Gold King Mine site consists of a mine adit and waste rock piles in the Cement Creek watershed. The mine historically discharged low pH, metals-laden water at a flow rate of approximately 100 gallons per minute (gpm). The water flows through a concrete channel, through a Parshall flume, through a plastic conduit, over a steep waste rock pile, and either into the subsurface (low flow), or toward North Fork Cement Creek. A pond was constructed at the base of the waste rock pile to collect water during 2014 site activities. North Fork Cement Creek flows into Cement Creek, which discharges to the Animas River in Silverton, Colorado.

On August 5, 2015, approximately 1 million gallons of acidic metals-laden water was unexpectedly released from the Gold King Mine. The mine water flowed across the site and to Cement Creek and then to the Animas River in Silverton, Colorado. Historically, EPA and the State of Colorado Division of Mining Reclamation and Safety (DRMS) had been working to control the existing flow from the Gold King Mine along with similar discharge that was emanating from the nearby Red and Bonita mine site. The project team was setting up to incorporate the flow from the Gold King Mine into the ongoing treatment of the flow from the Red and Bonita Mine when water that had been dammed in the Gold King Mine behind a collapsed section of adit broke through rock and debris.

PROJECT GOAL - The goal of the study is to determine the impact of the release on downstream waters and water users.

PROJECT AREA - The study area includes the Gold King Mine site and downstream locations potentially impacted from the Gold King release including Cement Creek and the Animas River.

PROJECT TASKS - EPA has requested that START assist to:

- a. Collect samples from areas potentially affected by the release, including surface water, sediment, groundwater, and/or soil
- b. Provide GPS data for sampling locations
- c. Provide georeferenced site photodocumentation
- d. Monitor conditions at the on-site water treatment at the Gold King Mine area

PROJECT UPDATE

This SAP/QAPP was originally issued on 8/8/2015 for the emergency response to the Gold King Mine release. This update, Revision 1, was provided for approval on 9/11/2015 for the purposes of 1) formally incorporating the previously submitted addendums into the document and 2) formally documenting inclusion of both the original assigned TDD 0001-1508-04 and the mine treatment TDD 0001-1509-02.

Introduction

This Sampling and Analysis Plan (SAP)/Quality Assurance Project Plan (QAPP) identifies the data collection activities and associated QA/QC measures specific to the mine water release that occurred on August 5, 2015 from the Gold King Mine site (the Site) located near Silverton, San Juan County, Colorado.

Sampling for this emergency response field mobilization related to the removal activities will consist of surface water and sediment sampling at specific locations downstream from the Red and Bonita Removal site and the Gold King Mine site (the Site(s)) on the Cement Creek and Animas River. This SAP/QAPP has been prepared as part of the emergency response activities for the site(s). Any deviations or modifications to the approved SAP/QAPP will be documented using the Revision Log.

This SAP/QAPP is produced in accordance with the Uniform Federal Policy for Quality Assurance Project Plans (UFP-QAPP). A QAPP is a formal document describing in comprehensive detail the necessary quality assurance (QA), quality control (QC), and other technical activities that must be implemented to ensure that the results of the work performed will satisfy the stated performance criteria. A QAPP presents the steps that should be taken to ensure that environmental data collected are of the correct type and quality required for a specific decision or use. The UFP-QAPP is a consensus document prepared by the Intergovernmental Data Quality Task Force (IDQTF).

Addendums to this document will be issued if needed to address any new procedures required.

Project Organization and Team

Refer to the QAPP Worksheet 3 & 5, and 4, 7, & 8 for the program organizational chart, communication pathways, personnel responsibilities and qualifications, and special personnel training requirements. Project-specific information is provided below.

The following are key individuals identified for this project:

Name	Title/Role	Organization	Receive Copy of SAP?
Pete Stevenson	OSC	EPA	Y
Steve Way	OSC	EPA	Y
Hays Griswold	OSC	EPA	Y
Craig Myers	OSC	EPA	Y
John West	Project Team Lead	START	Y
Elliott Petri	Engineer	START	Y
Jan Christner	Principal Engineer	START	Y
Roy Weindorf	Senior Geoscientist	START	Y
David Robinson	Project Manager	START	Y

The program QA Manager and the Project Manager will maintain the approved SAP/QAPP on file. The PTL will distribute the most current copy of the project QA documents via electronic or hard copy, as directed by the OSC. Files for this project will be kept in accordance with Section H.20 of Contract No.: EP-S8-13-01, stating a length of 10 years from close of the project or end of litigation.

The following summarizes the relationship of the UFP-QAPP worksheets to the QA/G5 guidance.

Crosswalk: UFP-QAPP Workbook to 2106-G-05 QAPP

Optimized UFP-QAPP Worksheets		2106-G-05 QAPP Guidance Section	
A. Project Management and Objectives			
1 & 2	Title and Approval Page	2.2.1	Title, Version, and Approval/Sign-Off
3 & 5	Project Organization and QAPP Distribution	2.2.3	Distribution List
		2.2.4	Project Organization and Schedule
4, 7, & 8	Personnel Qualifications and Sign-Off Sheet	2.2.1	Title, Version, and Approval/Sign-Off
		2.2.7	Special Training Requirements and Certifications
6	Communication Pathways	2.2.4	Project Organization and Schedule
9	Project Planning Session Summary	2.2.5	Project Background, Overview, and Intended Use of Data
10	Conceptual Site Model (CSM)	2.2.5	Project Background, Overview, and Intended Use of Data
11	Project/Data Quality Objectives	2.2.6	Data/Project Quality Objectives and Measurement Performance Criteria
12	Measurement Performance Criteria	2.2.6	Data/Project Quality Objectives and Measurement Performance Criteria
13	Secondary Data Uses and Limitations	Chapter 3	QAPP ELEMENTS FOR EVALUATING EXISTING DATA
14 & 16	Project Tasks & Schedule	2.2.4	Project Organization and Schedule
15	Project Action Limits and Laboratory-Specific Detection/Quantitation Limits	2.2.6	Data/Project Quality Objectives and Measurement Performance Criteria
B. Measurement/Data Acquisition			
17	Sampling Design and Rationale	2.3.1	Sample Collection Procedure, Experimental Design, and Sampling Tasks
18	Sampling Locations and Methods	2.3.1	Sample Collection Procedure, Experimental Design, and Sampling Tasks
		2.3.2	Sampling Procedures and Requirements
19 & 30	Sample Containers, Preservation, and Hold Times	2.3.2	Sampling Procedures and Requirements
20	Field Quality Control (QC)	2.3.5	QC Requirements
21	Field Standard Operating Procedures (SOPs)	2.3.2	Sampling Procedures and Requirements

Optimized UFP-QAPP Worksheets		2106-G-05 QAPP Guidance Section	
22	Field Equipment Calibration, Maintenance, Testing, and Inspection	2.3.6	Instrument/Equipment Testing, Calibration and Maintenance Requirements, Supplies and Consumables
23	Analytical SOPs	2.3.4	Analytical Methods Requirements and Task Description
24	Analytical Instrument Calibration	2.3.6	Instrument/Equipment Testing, Calibration and Maintenance Requirements, Supplies and Consumables
25	Analytical Instrument and Equipment Maintenance, Testing, and Inspection	2.3.6	Instrument/Equipment Testing, Calibration and Maintenance Requirements, Supplies and Consumables
26 & 27	Sample Handling, Custody, and Disposal	2.3.3	Sample Handling, Custody Procedures, and Documentation
28	Analytical QC and Corrective Action	2.3.5	QC Requirements
29	Project Documents and Records	2.2.8	Document and Records Requirements
C. Assessment/Oversight			
31, 32, & 33	Assessments and Corrective Action	2.4	ASSESSMENTS AND DATA REVIEW (CHECK)
		2.5.5	Reports to Management
D. Data Review			
34	Data Verification and Validation Inputs	2.5.1	Data Verification and Validation Targets and Methods
35	Data Verification Procedures	2.5.1	Data Verification and Validation Targets and Methods
36	Data Validation Procedure	2.5.1	Data Verification and Validation Targets and Methods
37	Data Usability Assessment	2.5.2	Quantitative and Qualitative Evaluations of Usability
		2.5.3	Potential Limitations on Data Interpretation
		2.5.4	Reconciliation with Project Requirements

Worksheet 1 & 2 — Title and Approval Page

(UFP-QAPP Manual Section 2.1)

(EPA 2106-G-05 Section 2.2.1)

1. Project Identifying Information

- a) **Site Name/Project Name:** Gold King Mine Release
- b) **Site Location/Number:** Silverton, San Juan County, Colorado.
- c) **Contract/Work Assignment Number:** EP-S8-13-01/TDD 1508-04

- 2) **List Plans and reports from previous investigation relevant to this project.**
Not applicable

Lead Investigative Organization's Program Manager:

W. Scott Butterfield, CHMM/WESTON
Printed Name/Title

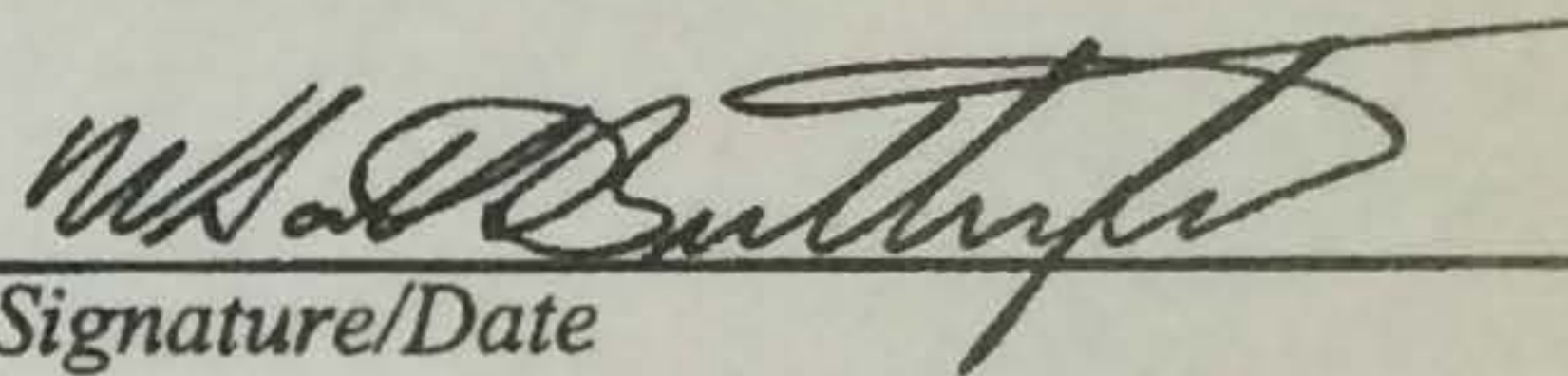
 9/11/15
Signature/Date

Lead Investigative Organization's Project Manager:

David Robinson/WESTON
Printed Name/Title

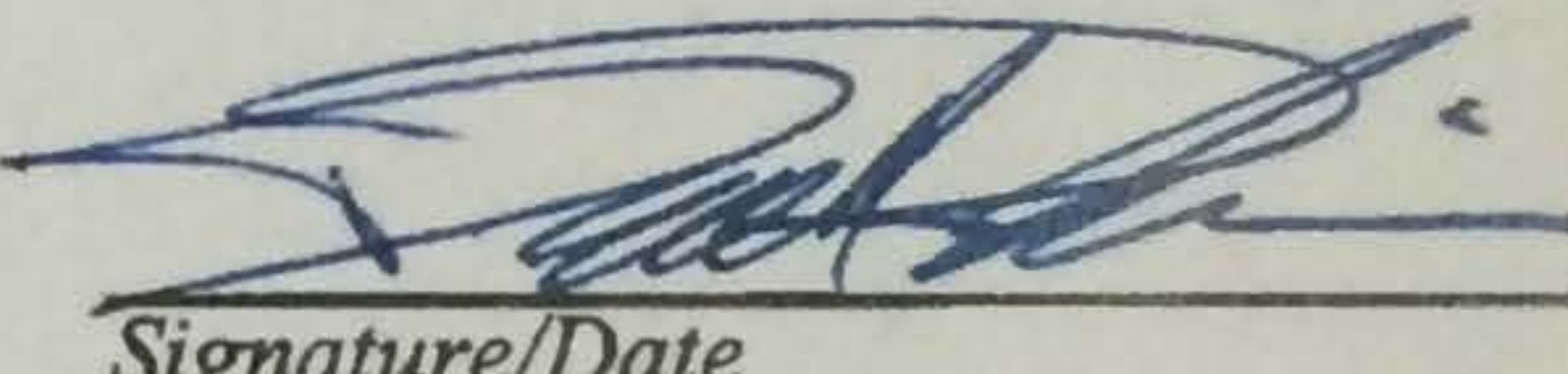
 9/11/15
Signature/Date

Lead Investigative Organization's Delegated Quality Assurance Manager:

Tana Jones/WESTON
Printed Name/Title

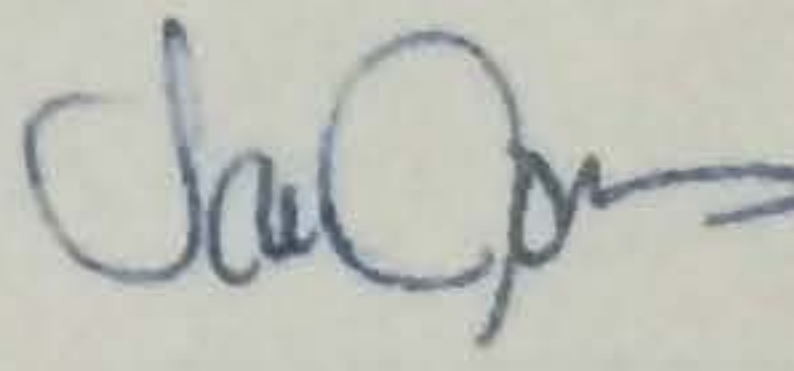
 9/11/15
Signature/Date

Federal Regulatory Agency On Scene Coordinator/Delgated Approval Officer:

Craig Myers/EPA
Printed Name/Title

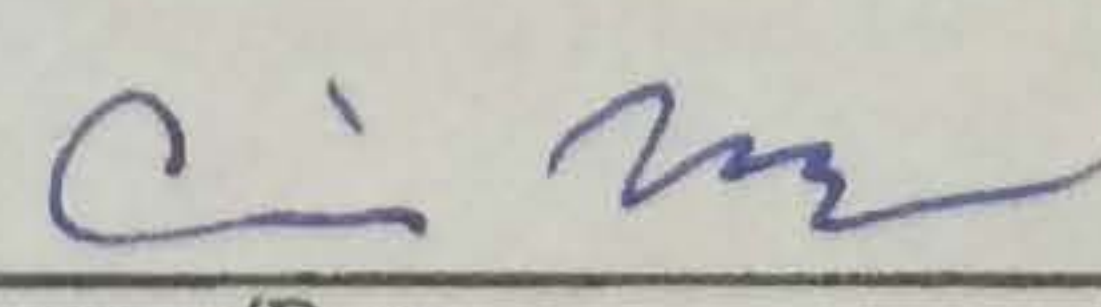
 9/11/15
Signature/Date

Document Control Numbering System: W0267.1E.00614

Worksheet 3 & 5 — Project Organization and QAPP Distribution

(UFP-QAPP Manual Section 2.3 and 2.4)

(EPA 2106-G-05 Section 2.2.3 and 2.2.4)

The most current and approved copy of the QAPP will be delivered to recipients using a web-based system in use by EPA and START at the time of submittal.

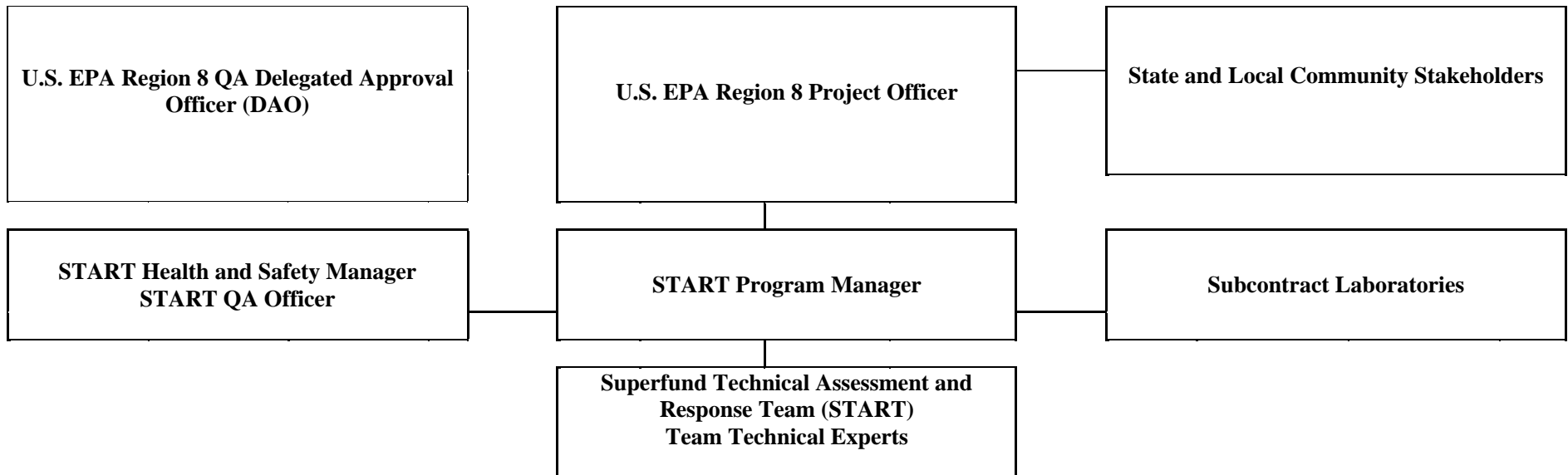

Worksheet 4, 7 & 8 — Personnel Qualifications

(UFP-QAPP Manual Sections 2.3.2 - 2.3.4)

(EPA 2106-G-05 Section 2.2.1 and 2.2.7)

Name	Project Title / Role	Education / Experience	Specialized Training / Certifications ¹	Training Provider ²
W. Scott Butterfield, CHMM	Program Manager / Point of contact (POC) with EPA CO, COR, and Team Leader. Ensures adherence to contract and project requirements/deliverables.	B.S., Environmental Science, M.S., Zoology/Estuarine Ecology / 32 years of diversified technical and program management experience on EPA Superfund contracts.	FEMA IS Levels 100, 200, 700, and 800, and EPA Hazard Ranking System, Documentation Record, Preliminary Assessment, Site Inspection, Air Monitoring, Emergency Response, Level A Team, and Multi-Media Sampling / Certified Hazardous Materials Manager (CHMM)	WESTON, Registered Training Organization – Various
David Robinson	PM / Operational POC for project level communications with EPA Removal Managers (RMs) and Emergency Response Managers (ERMs), ensure performance associated with the contract, coordinate and communicate with EPA in the pre-planning phase of individual Technical Direction Document (TDD) assignments, provide technical direction to the Project Team Lead (PTL), and support any functions delegated by the Program Manager.	B.S., Chemistry / Over 25 years' environmental experience, 7 years experience on Region 5 START contracts.	FEMA IS Levels 100, 200, 300, 400, 700, and 800; 32-Hour Advanced Radiation Training; Response Readiness Training; Biological Response Training; Nuclear, Biological, and Chemical Emergency Responders Training; 40-Hour OSHA Hazardous Waste Site Worker Training; 8-Hour OSHA Refresher Training; First Aid and CPR	WESTON, Registered Training Organization – Various

Name	Project Title / Role	Education / Experience	Specialized Training / Certifications ¹	Training Provider ²
Jan Christner, P.E.	Delegated QA Manager / Delegated authority for quality systems implementation and management, review and approval of quality documents, review and approval of contract deliverables, and performing quality assessments and quality systems audits. Maintains authority over implementation of quality systems management.	B.S., Chemical Engineering, M.S. Environmental Science and Engineering / Over 18 years of environmental experience including emergency response; planning and preparedness; removal assessments and actions; and remedial assessments, evaluations, and actions	Professional Engineer (P.E.); Nuclear, Biological, and Chemical Emergency Responders Training; 40-Hour OSHA Hazardous Waste Site Worker Training; 8-Hour OSHA Refresher Training; First Aid and CPR	URS, WESTON, Registered Training Organization – Various
John West	PTL / Supervises field sampling and coordinates all field activities. Ensures all training/certifications are satisfied for field team personnel.	TBD	40-Hour OSHA Hazardous Waste Site Worker Training; 8-Hour OSHA Refresher Training; First Aid and CPR	WESTON, Registered Training Organization – Various
Elliot Petri	Field Support / Assist with field sampling activities.	M.S., Environmental Science and Engineering / 3+ years of experience in the field of environmental sciences including Phase I/II ESAs, site investigations, assessments and remediation.	40-Hour OSHA Hazardous Waste Site Worker Training; 8-Hour OSHA Refresher Training; First Aid and CPR.	WESTON, Registered Training Organization – Various
Roy Weindorf	Assistant PTL / Assists PTL and supervises field sampling and coordinates all field activities. Ensures all training/certifications are satisfied for field team personnel.	B.S., Geology / Over 10 years of project experience including conducting site assessments, Phase I/II ESAs. FSs, etc.	40-Hour OSHA Hazardous Waste Site Worker Training; 8-Hour OSHA Refresher Training; 30-Hour OSHA Field Supervisor Course; First Aid and CPR; P.G. in Texas	WESTON, Registered Training Organization – Various

Name	Project Title / Role	Education / Experience	Specialized Training / Certifications ¹	Training Provider ²
Other field Technicians Geologists, Environmental Scientists, Engineers as needed	TBD	TBD	40-Hour OSHA Hazardous Waste Site Worker Training; 8-Hour OSHA Refresher Training; First Aid and CPR	Registered Training Organization – Various

¹ Training records and/or certificates are on file at the Weston Solutions, Inc., West Chester, Pennsylvania office and are available upon request.

² Training provider and date of training will vary from person to person due to individual scheduling of training.

Worksheet 6 — Communication Pathways

(UFP-QAPP Manual Section 2.4.2)

(EPA 2106-G-05 Section 2.2.4)

Communication Drivers	Organization	Name	Contact Information	Procedures (Timing, Pathways, Documentation, etc.)
Regulatory Agency Interface	EPA CO	Maria Houston	303-312-7022	Maintain lines of communication between EPA Contracting Officer and WESTON Program Manager.
Approves Site-Specific QA Documents	EPA OSC/Task Monitor	TBD	TBD	Approves site-specific FSPs, SAPs, and/or QAPPs in accordance with EPA guidance documents and policy. Provides guidance or instruction for site-specific QA documents.
POC with EPA CO	WESTON Program Manager	W. Scott Butterfield, CHMM	303-729-6113	Maintain lines of communication between EPA CO, WAM/COR and Team Leader.
Manage all Project Phases	WESTON PM	David Robinson	937-572-3630	Manage day to day operations of the project. Reports to Program Manager and EPA WAM/COR issues with cost, schedule, etc.
Health and Safety Monitoring/Reporting	WESTON Health and Safety Manager	David Robinson	937-572-3630	Communicates with PTL and PM regarding safety issues/reporting on a daily basis, when required.
QAPP Changes Prior to Field Work and Field and Analytical Corrective Actions	WESTON Delegated QA Manager	Tana Jones.	720-232-4399	Communicates changes to Removal Action and Emergency Response QAPP to QA Officer and site-specific FSPs, SAPs, and/or QAPPs to PM and EPA WAM/COR. Communicates with PTL to determine need for field and analytical corrective actions.
QAPP Changes in the Field and Daily Field Progress Reports	WESTON PTL	John West,	303-729-6148	Communicate QAPP changes and field activities to Delegated QA Manager, EPA WAM/COR, and PM on a daily basis, when required.
QAPP Amendments	WESTON QA Officer	Cecilia H. Shappee, P.E.	713-985-6701	Major changes to the Removal Action and Emergency Response QAPP must be approved by the QA Officer and Delegated QA Manager before implementation.
Data Tracking and Management, Release of Analytical Data	WESTON Data Manager	John Lucotch	970-301-1416	The need for corrective actions will be determined by the Delegated QA Manager upon review of the data. No analytical data will be released prior to validation and all releases must be approved by the Delegated QA Manager and EPA WAM/COR.

Worksheet 6 — Communication Pathways (Continued)

(UFP-QAPP Manual Section 2.4.2)

(EPA 2106-G-05 Section 2.2.4)

Communication Drivers	Organization	Name	Contact Information	Procedures (Timing, Pathways, Documentation, etc.)
Lab Data Quality Issues	Laboratory PM	TBD	TBD	Laboratory PM will report any issues with project samples to the Delegated QA Manager within 2 business days.

Worksheet 9 — Project Planning Session Summary

(UFP-QAPP Manual Section 2.5.1 and Figures 9-12)
(EPA 2106-G-05 Section 2.2.5)

Date: 8/7/15

Location: Email – OSC Joyce Ackerman to START Program Manager Scott Butterfield

Purpose: Identification of sampling needs for Gold King Mine release assessment

Notes/Comments: OSC Joyce Ackerman sent email to START that identified needs for sampling based on public meeting that OSC Pete Stevenson attended. START followed up with brief phone call with OSC Stevenson confirming that START will prepare the Sampling and Analysis Plan (SAP). The following are the anticipated sampling needs:

- Water quality samples with field parameters and at drinking water intakes
- Residential wells along the river on request
- Water in irrigation ditches that were impacted
- River sediments
- Sediment in irrigation ditches
- Soil samples from irrigated land
- Also consider long term monitoring methods

Consensus Decisions Made:

- START to prepare SAP

Action Items:

Action	Responsible Party	Due Date
Prepare site-specific SAP	START	8/9/15

Worksheet 10 — Conceptual Site Model

(UFP-QAPP Manual Section 2.5.2)

(EPA 2106-G-05 Section 2.2.5)

- **Problem Definition**

The Gold King Mine site consists of a mine adit and waste rock piles in the Cement Creek watershed. The mine historically discharged low pH, metals-laden water at a flow rate of approximately 100 gallons per minute (gpm). The water flows through a concrete channel, through a Parshall flume, through a plastic conduit, over a steep waste rock pile, and either into the subsurface (low flow), or toward North Fork Cement Creek. A pond was constructed at the base of the waste rock pile to collect water during 2014 site activities. North Fork Cement Creek flows into Cement Creek, which discharges to the Animas River in Silverton, Colorado.

On August 5, 2015, approximately 1 million gallons of acidic metals-laden water was unexpectedly released from the Gold King Mine. The mine water flowed across the site and to Cement Creek and then to the Animas River in Silverton, Colorado. Historically, EPA and the State of Colorado Division of Mining Reclamation and Safety (DRMS) had been working to control the existing flow from the Gold King Mine along with similar discharge that was emanating from the nearby Red and Bonita mine site. The project team was setting up to incorporate the flow from the Gold King Mine into the ongoing treatment of the flow from the Red and Bonita Mine when water that had been dammed in the Gold King Mine behind a collapsed section of adit broke through rock and debris.

- **Background Information/Site History**

The Red and Bonita Mine and the Gold King Mine are in the Cement Creek watershed, which originates high in the rugged San Juan Mountains of southwestern Colorado near the San Juan County and Ouray County line on the south slopes of Red Mountain Number 3 and the north slopes of Storm Peak.

The rugged and relatively inaccessible western San Juan Mountains were first prospected in the area around Silverton in 1860. The extension of the railroad from Silverton up Cement Creek to Gladstone in 1899 encouraged the mining of low grade ores, and the establishment of a lead-zinc flotation plant in 1917 allowed for the treatment of the low grade complex ores found in the area. Over a 100-year period between 1890 and 1991, mining activities in the upper Animas River Basin, including Cement Creek, produced the waste rock and mill tailings sources from which contamination spread throughout the surface water pathway. Over 18 million tons of ore were mined from the Upper Animas River Basin area, with more than 95 percent of this being dumped directly into the Animas River and its tributaries in the form of mill waste. Older waste rock piles and stope fillings were reworked and sent to mills as technology allowed lower grade ores to be processed economically. A great deal of abandoned waste was also milled during World War II when many older mining and milling structures were cannibalized for scrap metal. The last producing mine in the area was the Sunnyside Mine, which ceased production in 1991. The closing of the Sunnyside mine occurred after Lake Emma drained into the mine and out the American Tunnel into Cement Creek in 1978. The flood water from the Lake Emma “blow-out” was reported to have flowed down Cement Creek in a 10-foot wall of water that would have transported a large quantity of tailing and other mine waste down Cement Creek to the Animas River.

Numerous historic and now abandoned mines exist within a two-mile radius of Gladstone. They include: the Upper Gold King 7 Level, American Tunnel, Grand Mogul, Mogul, Red and Bonita, Evelynne, Henrietta, Joe and John, and Lark mines. Some of these mines have acid mine drainage that flows between 30 and 300 gpm directly or indirectly into Cement Creek and eventually into the Animas River. The confluence of Cement Creek and the Animas River is located approximately eight miles downstream of Gladstone.

The Animas River Stakeholders Group (ARSG), U.S. Bureau of Land Management (BLM), DRMS, EPA, and private stakeholders have participated in various projects to manage mine waste and to reduce the flow of contaminated water in the watershed. In addition, under the terms of a consent decree with the State of Colorado, Sunnyside Gold Mine Company performed several large scale projects related to historic operations on properties associated with the company's operations. One project was plugging (installing concrete bulkheads) within the Sunnyside mine workings, including the American Tunnel, during the period from 1996 to 2002. The American Tunnel is located in Gladstone, approximately $\frac{3}{4}$ to 1 mile south of the Red and Bonita and Gold King mines. During the mine operation, the American Tunnel discharged approximately 1,700 gpm of metal laden water and was treated prior discharging to Cement Creek. Following the installation of the last of the three plugs, flow from the American Tunnel has decreased to approximately 100 gpm, the result of leakage around the concrete bulkhead. The flow from the Red and Bonita Mine, the Gold King (Level 7) Mine, and the Mogul Mine all experienced significant increases in flow following the plugging of the American Tunnel.

Contaminants found in the Red and Bonita discharge water include low pH and metals. Cadmium concentrations from the mine discharge ranged from 33.3 micrograms per liter ($\mu\text{g/L}$) to 39.3 $\mu\text{g/L}$, copper concentrations ranged from 4.5 $\mu\text{g/L}$ to 50.6 $\mu\text{g/L}$, iron concentrations range from 76,700 $\mu\text{g/L}$ to 97,600 $\mu\text{g/L}$, lead concentrations ranged from 34 $\mu\text{g/L}$ to 71.2 $\mu\text{g/L}$, and zinc concentrations ranged from 13,600 $\mu\text{g/L}$ to 17,500 $\mu\text{g/L}$.

Contaminants in the Gold King discharge water include low pH and metals. From 2009 to 2011, cadmium concentrations from the mine discharge ranged from 38 micrograms per liter ($\mu\text{g/L}$) to 136 $\mu\text{g/L}$, copper concentrations ranged from 2400 $\mu\text{g/L}$ to 12,000 $\mu\text{g/L}$, lead concentrations ranged from 2 $\mu\text{g/L}$ to 29 $\mu\text{g/L}$, and zinc concentrations ranged from 14,500 $\mu\text{g/L}$ to 44,700 $\mu\text{g/L}$.

Background Reference:

- URS Operating Services, Inc. 2010. Red and Bonita Mine Remedial Action Field Sampling Plan. October 2010.
- Weston Solutions Inc., 2014. Sampling and Analysis Plan for Red and Bonita Mine. Nov 2014.

Worksheet 11 — Project/Data Quality Objectives

(UFP-QAPP Manual Section 2.6.1)

(EPA 2106-G-05 Section 2.2.6)

Data quality objectives are based on the following seven steps.

State the Problem

On August 5, 2015, approximately 1 million gallons of acidic metals-laden water and sludge was unexpectedly released from the Gold King Mine. The mine water flowed across the site and to Cement Creek and then to the Animas River in Silverton, Colorado.

EPA has requested that START assist to:

- a. Collect samples from areas potentially affected by the release, including surface water, sediment, groundwater, and/or soil
- b. Provide GPS data for sampling locations
- c. Provide georeferenced site photodocumentation

Identify the Goals of the Study

The goals of the study are to:

- Determine the impact of the release on downstream waters and water users.

The primary study questions are:

- What areas were affected by the release from Gold King Mine?
- What are the water quality conditions, as indicated by field and laboratory analyses, in Cement Creek and the Animas River?
- Based on laboratory analyses, are other media such as sediment, soil or groundwater affected by the mine water release?

Identify Information Inputs

To support the above objectives, the following data will be collected:

- Surface water and sediment samples will be collected and analyzed for metals. If needed, groundwater and soil may also be sampled.
- Field measurements of surface water and/or groundwater quality.
- Geospatial data of sampling locations.
- Field documentation and photographs of site activities.

Define the Boundaries of the Study

Spatial Boundaries: The study area includes the Gold King Mine site and downstream locations potentially impacted from the Gold King release.

Temporal Boundaries: The study will represent conditions from after the release from the Gold King Mine and ending at an as yet undetermined date. A sampling schedule and sampling plan is included in Worksheets 14, 16 and 17.

Practical constraints on data collection: Scheduling adjustments will be made if physical constraints on planned field events occur due to weather, safety considerations, or problems that may impact the technical quality of the measurements.

Develop the Analytic Approach

Samples will be collected from locations designated in the field by an EPA OSC. Samples will be sent for laboratory analysis of total and dissolved TAL metals and other parameters as directed by the OSC.

The results may be compared to WQS for Animas River Stream Segment 3b (Animas River) or 7 (Cement Creek), Maximum Contaminant Levels (MCLs), and/or other benchmarks as directed by the EPA OSC.

Specify Performance or Acceptance Criteria

All data will be reviewed and verified to ensure that they are acceptable for the intended use. Data will be validated at the request of the EPA OSC.

Decision errors will be limited to the extent practicable by following approved U.S. EPA methods and applicable SOPs listed in Worksheet #21. Any deviation from the SAP will be documented.

Develop the Detailed Plan for Obtaining Data

Water, sediment, and soil samples will be collected at locations designated by the EPA OSC. Worksheets 17, 18, 20, and 21 present the sampling design and procedures.

Field water quality parameters will be obtained using a Horiba (U50 or U53) or similar water quality meter. Field monitoring will be used to measure the quality of water, with emphasis on pH measurements. Visual observations of water clarity will be recorded.

Worksheets 19, 20, 24-28 and 30 specify analytical requirements. Data from the laboratories will be delivered in an electronic data deliverable and reported in the site activities report. A site-specific Data Management Plan is provided in Appendix B.

Worksheet 12 — Measurement Performance Criteria Tables
(UFP-QAPP Manual Section 2.6.2)
(EPA 2106-G-05 Section 2.2.6)

The following are typical examples for Inorganics for all media.

Matrix: All
Analytical Group or Method: Inorganics
Concentration Level: All

DQI	QC Sample or Measurement Performance Activity	MPC
Field Precision	Field Duplicate	1 per 10 samples RPD determined on a sampling method-specific basis
Field Representativeness/ Accuracy/Bias	Equipment Rinsate Blank	1 per 20 samples/matrix or 1 per day <1/2 LOQ
Accuracy/Bias	MS/MSD	1 per 20 samples per matrix RPD <20%
Laboratory Precision	Laboratory Duplicate	1 per 20 samples per matrix RPD <20%
Accuracy/Precision	Initial Calibration	Daily prior to sample analysis (minimum 1 standard and a blank)
Accuracy/Bias	Initial Calibration Verification	Daily after initial calibration All analytes within ±10% of expected value
Accuracy/Bias	Calibration Blank (CB) Initial Calibration Blank/Continuing Calibration Blank (ICB/CCB)	After every calibration/verification No analytes detected ≥ Limit of Detection (LOD)
Precision/Accuracy	Calibration Verification (Instrument Check Standard)	At beginning of analytical sequence, after every 10 samples and at the end of the analysis sequence All analytes within ±10% of expected value and RSD of replicate integrations <5%
Precision	Interference Check Solution	At beginning of analytical run ± 20% of the expected value
Precision/Accuracy	Serial Dilution	Method-specific
Accuracy/Bias	Post Digestion Blank	Each digestion batch %R. Analyte-specific
Laboratory Representativeness/ Accuracy/Bias	Method Blank	1 per batch per matrix or 1 per 20 samples, whichever is more frequent No analyte ≥ RL
Laboratory Accuracy/ Sensitivity	LCS	1 per batch per matrix or 1 per 20 samples, whichever is more frequent No analyte ≥ LOQ

Worksheet 13 — Secondary Data Uses and Limitations

(UFP-QAPP Manual Section 2.7)

(EPA 2106-G-05 Chapter 3: QAPP Elements for Evaluating Existing Data)

Sources and types of secondary data include but are not limited to the following:

Data Type	Data Source (originating organization, report title and date)	Data Uses Relative to Current Project	Factors Affecting the Reliability of Data and Limitations on Data Use
Soils	United States Department of Agriculture (USDA) Natural Resource Conservation Service (NRCS) Web Soil Survey and Soil Data Mart	Identify soil types, composition, elevation, precipitation, setting, properties and qualities, profile, land capability and farmland classification	
Geology/Hydrology	United States Department of the Interior Geologic Survey (USGS) Topographic and Geologic Maps, State Agencies/EPA My WATERS Mapper	Identify area Geology, topography, surface water bodies, hydrologic units/watersheds, water quality, etc.	
Streams/Drainages	EPA My WATERS Mapper and USGS Topographic Maps	Topography, surface water bodies, hydrologic units/watersheds, water quality, etc.	
Registered Wells	State Databases	Identify well locations, drinking water wells, and groundwater use	
Meteorological	National Weather Service	Seasonal fluctuations in storm water runoff	
Property Boundaries	County Assessor and Plat Maps	Identify property boundaries to determine site requirements for assessment	
Environmentally Sensitive Areas	U.S. and State Fish & Wildlife Service Maps, Publications, and Databases	Identify sensitive and endangered species and environments potentially present on or in removal action/emergency response area	
Wetlands	USDA NRCS Web Soil Survey and Soil Data Mart (Hydric Soils List), and U.S. and State Fish & Wildlife Databases	Identify wetlands and associated sensitive and endangered species and environments potentially present on or in removal action/emergency response area	
Historical and Current Site Use and Investigations	Historical Records, Previous Investigations, Visual Site Reconnaissance, and Interviews	Supplemental background information on historical site use and current site conditions, and previous investigations	

The project team will carefully evaluate the quality of secondary data (in terms of precision, bias, representativeness, comparability, and completeness) to ensure they are of the type and quality necessary to support their intended uses. When evaluating the reliability of secondary data and determining limitations on their uses, the project team will consider the source of the data, the time period during which they were collected, data collection methods, potential sources of uncertainty, the type of supporting documentation

Worksheet 13 — Secondary Data Uses and Limitations (Continued)

(UFP-QAPP Manual Section 2.7)

(EPA 2106-G-05 Chapter 3: QAPP Elements for Evaluating Existing Data)

available, and the comparability of data collection methods to the currently proposed methods. With respect to secondary analytical data that will be utilized to support critical decisions, such as comparison of contaminant levels with applicable standards, a detailed review of the data will be necessary to determine the usability of the data. In addition to the qualitative rating of the data source, the project team should complete a data quality review and document the review in a data usability summary. The protocol for completing the data usability report is provided in Worksheet 37.

In accordance with EPA guidance documents *A Summary of General Assessment Factors for Evaluating the Quality of Scientific and Technical Information* (June 2003) and *Guidance for Evaluating and Documenting the Quality of Existing Scientific and Technical Information* (December 2012) (Appendix Q), the following assessment factors will be utilized to assess the quality and relevance of scientific and technical information:

1. **Soundness** – the extent to which the scientific and technical procedures, measures, methods or models employed to generate the information are reasonable for, and consistent with, the intended application.
2. **Applicability and Utility** – the extent to which the information is relevant for the Agency’s intended use.
3. **Clarity and Completeness** – the degree of clarity and completeness with which the data, assumptions, methods, quality assurance, sponsoring organizations and analyses employed to generate the information are documented.
4. **Uncertainty and Variability** – the extent to which the variability and uncertainty (quantitative and qualitative) in the information or in the procedures, measures, methods or models are evaluated and characterized.
5. **Evaluation and Review** – the extent of independent verification, validation and peer review of the information or of the procedures, measures, methods or models.

The type of information, sources of information and quantity of information will be project-specific. The following table can be utilized and/or modified as appropriate in the development of the site-specific FSP, SAP and/or QAPP and site report to capture the review of the secondary data assessment factors. Assessment factors will be rated as Acceptable, Marginal, Unacceptable, Not Applicable, or Indeterminate.

Citation	Reference Type	Soundness	Applicability and Utility	Clarity and Completeness	Uncertainty and Variability	Evaluation and Review

Worksheet 14 & 16 —Project Tasks & Schedule

(UFP-QAPP Manual Section 2.8.2)

(EPA 2106-G-05 Section 2.2.4)

Activity	Responsible Party	Planned Start Date	Planned Completion Date	Deliverable(s)	Deliverable Due Date
Project Initiation	EPA/START	August 6, 2015	August 6, 2015	N/A	N/A
Develop a SAP for Removal and Emergency Response Activities and the EPA Region 8 QA Document Review Crosswalk	START	August 7, 2015	August 8, 2015	Develop a SAP for Removal and Emergency Response Activities and the EPA Region 8 QA Document Review Crosswalk	August 9, 2015
Develop Health and Safety Plan (HASP)	START	August 6, 2015	August 6, 2015	HASP	August 6, 2015
Mobilization/Demobilization	START	August 6, 2015	August 6, 2015	Field Notes	N/A
Sample Collection Tasks	START	August 6, 2015	TBD	Field Notes	TBD
Analytical Tasks	START/ Laboratory	August 6, 2015	TBD	Field Notes/Laboratory Reports	TBD
Quality Control Tasks	START	August 6, 2015	TBD	Report of Analyses/Data Package	TBD
Validation	START	August 6, 2015	TBD	Validation Summary Report	TBD

Activity	Responsible Party	Planned Start Date	Planned Completion Date	Deliverable(s)	Deliverable Due Date
Summarize Data	START	August 6, 2015	TBD	Daily Update	TBD

Worksheet 15 — Project Action Limits and Laboratory-Specific Detection/Quantitation Limits

(UFP-QAPP Manual Sections 2.6.2.3 and Figure 15)

(EPA 2106-G-05 Section 2.2.6)

The following information provides representative benchmarks that may be useful for comparison of analytical sample results. Due to the ongoing nature of the project, multiple benchmarks may be appropriate for comparison. Benchmarks utilized for data analysis and reporting will be documented within each report. The examples below are for water samples collected from residential taps based on EPA screening levels and for surface water samples based on Colorado water quality standards. Multiple laboratories may be utilized. Quantitation and detection limits may vary between laboratories based on localized equipment.

Matrix: Water

Analytical Method: 200.7, 200.8, 245.1

Concentration level (if applicable): Low to High

Analyte	EPA Tapwater (µg/L)	PAL Reference ¹	Project Quantitation Limit (PQL) Goal	Laboratory Quantitation Limit (LQL) ^{2,3}	Laboratory Detection Limit (LDL) ^{2,3}
Total Metals					
Aluminum	20000	EPA RSL Table	TBD	TBD	TBD
Antimony	7.8	EPA RSL Table	TBD	TBD	TBD
Arsenic	0.052	EPA RSL Table	TBD	TBD	TBD
Barium	3800	EPA RSL Table	TBD	TBD	TBD
Beryllium	25	EPA RSL Table	TBD	TBD	TBD
Cadmium	9.2	EPA RSL Table	TBD	TBD	TBD
Calcium	NE	EPA RSL Table	TBD	TBD	TBD
Chromium	NE	EPA RSL Table	TBD	TBD	TBD
Cobalt	6	EPA RSL Table	TBD	TBD	TBD
Copper	800	EPA RSL Table	TBD	TBD	TBD
Iron	14000	EPA RSL Table	TBD	TBD	TBD
Lead	15	EPA RSL Table	TBD	TBD	TBD
Magnesium	NE	EPA RSL Table	TBD	TBD	TBD
Manganese	430	EPA RSL Table	TBD	TBD	TBD
Mercury	0.63	EPA RSL Table	TBD	TBD	TBD
Molybdenum	100	EPA RSL Table	TBD	TBD	TBD

Analyte	EPA Tapwater (µg/L)	PAL Reference ¹	Project Quantitation Limit (PQL) Goal	Laboratory Quantitation Limit (LQL) ^{2,3}	Laboratory Detection Limit (LDL) ^{2,3}
Nickel	NE	EPA RSL Table	TBD	TBD	TBD
Potassium	390	EPA RSL Table	TBD	TBD	TBD
Selenium	100	EPA RSL Table	TBD	TBD	TBD
Silver	94	EPA RSL Table	TBD	TBD	TBD
Sodium	NE	EPA RSL Table	TBD	TBD	TBD
Thallium	0.2	EPA RSL Table	TBD	TBD	TBD
Vanadium	86	EPA RSL Table	TBD	TBD	TBD
Zinc	6000	EPA RSL Table	TBD	TBD	TBD
Dissolved Metals					
Aluminum	NE	EPA RSL Table	TBD	TBD	TBD
Antimony	NE	EPA RSL Table	TBD	TBD	TBD
Arsenic	NE	EPA RSL Table	TBD	TBD	TBD
Barium	NE	EPA RSL Table	TBD	TBD	TBD
Beryllium	NE	EPA RSL Table	TBD	TBD	TBD
Cadmium	NE	EPA RSL Table	TBD	TBD	TBD
Calcium	NE	EPA RSL Table	TBD	TBD	TBD
Chromium	NE	EPA RSL Table	TBD	TBD	TBD
Cobalt	NE	EPA RSL Table	TBD	TBD	TBD
Copper	NE	EPA RSL Table	TBD	TBD	TBD
Iron	NE	EPA RSL Table	TBD	TBD	TBD
Lead	NE	EPA RSL Table	TBD	TBD	TBD
Magnesium	NE	EPA RSL Table	TBD	TBD	TBD
Manganese	NE	EPA RSL Table	TBD	TBD	TBD
Mercury	NE	EPA RSL Table	TBD	TBD	TBD
Nickel	NE	EPA RSL Table	TBD	TBD	TBD
Potassium	NE	EPA RSL Table	TBD	TBD	TBD
Selenium	NE	EPA RSL Table	TBD	TBD	TBD
Silver	NE	EPA RSL Table	TBD	TBD	TBD
Sodium	NE	EPA RSL Table	TBD	TBD	TBD
Thallium	NE	EPA RSL Table	TBD	TBD	TBD
Vanadium	NE	EPA RSL Table	TBD	TBD	TBD

Analyte	EPA Tapwater (µg/L)	PAL Reference ¹	Project Quantitation Limit (PQL) Goal	Laboratory Quantitation Limit (LQL) ^{2,3}	Laboratory Detection Limit (LDL) ^{2,3}
Zinc	NE	EPA RSL Table	TBD	TBD	TBD

¹ EPA RSLs are screening levels used to consider whether additional assessment is needed

^{2,3} Terminology is project/laboratory-specific.

Colorado Water Quality Standards

TABLE III METAL PARAMETERS (Concentration in ug/l)						
METAL ⁽¹⁾	AQUATIC LIFE ⁽¹⁾⁽³⁾⁽⁴⁾⁽⁵⁾		AGRICULTURE ⁽²⁾	DOMESTIC WATER-SUPPLY ⁽²⁾	WATER + FISH ⁽⁷⁾	FISH INGESTION ⁽¹⁰⁾
	ACUTE	CHRONIC				
Aluminum	$e^{(1.3695[\ln(\text{hardness}))+1.8308]}$ (tot.rec.)	87 or $e^{(1.3695[\ln(\text{hardness}))-0.1158]}$ (tot.rec.) ⁽¹¹⁾			---	---
Antimony				6.0 (30-day)	5.6	640
Arsenic	340	150	100 ^(A) (30-day)	0.02 – 10 ⁽¹³⁾ (30-day) ⁽¹⁴⁾	0.02	7.6
Barium				1,000 ^(E) (1-day) 490 (30-day)	---	---
Beryllium			100 ^(A,B) (30-day)	4.0 (30-day)	---	---
Cadmium	$(1.136672-[\ln(\text{hardness}) \times 0.9151[\ln(\text{hardness})]-3.1485] \times e^{(0.041838)}) \times e$ (Trout)= $(1.136672-[\ln(\text{hardness}) \times 0.9151[\ln(\text{hardness})]-3.6236] \times e^{(0.041838)}) \times e$	$(1.101672-[\ln(\text{hardness}) \times 0.7990[\ln(\text{hardness})]-4.4451] \times e^{(0.041838)}) \times e$	10 ^(B) (30-day)	5.0 ^(E) (1-day)	---	---
Chromium III ⁽⁵⁾	$e^{(0.819[\ln(\text{hardness})]+2.5736)}$	$e^{(0.819[\ln(\text{hardness})]+0.5340)}$	100 ^(B) (30-day)	50 ^(E) (1-day)	---	---
Chromium VI ⁽⁵⁾	16	11	100 ^(B) (30-day)	50 ^(E) (1-day)	100(30-day)	---
Copper	$e^{(0.9422[\ln(\text{hardness})]-1.7408)}$	$e^{(0.8545[\ln(\text{hardness})]-1.7428)}$	200 ^(B)	1,000 ^(F) (30-day)	1,300	---
Iron		1,000(tot.rec.) ^(A,C)		300(dis) ^(F) (30-day)	---	---
Lead	$(1.46203-[(\ln(\text{hardness}) \times 1.46) \times e^{(0.145712)}]) \times e^{(1.273[\ln(\text{hardness})]-4.705)}$	$(1.46203-[(\ln(\text{hardness}) \times 1.273[\ln(\text{hardness})]-4.705) \times e^{(0.145712)}]) \times e^{(1.273[\ln(\text{hardness})]-4.705)}$	100 ^(B) (30-day)	50 ^(E) (1-day)	—	---
Manganese	$e^{(0.3331[\ln(\text{hardness})]+6.4676)}$	$e^{(0.3331[\ln(\text{hardness})]+5.8743)}$	200 ^(B) (30-day) ⁽¹²⁾	50(dis) ^(F) (30-day)	—	---
Mercury		FRV(fish) ⁽⁶⁾ = 0.01 (Total)		2.0 ^(E) (1-day)	—	---
Molybdenum			300 ^(D) (30-day) ⁽¹⁶⁾	210 (30-day)		

TABLE III METAL PARAMETERS (Concentration in ug/l)						
METAL ⁽¹⁾	AQUATIC LIFE ⁽¹⁾⁽³⁾⁽⁴⁾⁽⁵⁾		AGRICULTURE ⁽²⁾	DOMESTIC WATER-SUPPLY ⁽²⁾	WATER + FISH ⁽⁷⁾	FISH INGESTION ⁽¹⁰⁾
	ACUTE	CHRONIC				
Nickel	$e^{(0.846[\ln(\text{hardness}))+2.253]}$	$e^{(0.846[\ln(\text{hardness}))+0.0554]}$	200 ^(B) (30-day)	100 ^(E) (30-day)	610	4,600
Selenium ⁽⁹⁾	18.4	4.6	20 ^(B,D) (30-day)	50 ^(E) (30-day)	170	4,200
Silver	$\frac{1}{2}e^{(1.72[\ln(\text{hardness}))-6.52]}$	$e^{(1.72[\ln(\text{hardness}))-9.06]}$ (Trout) = $e^{(1.72[\ln(\text{hardness}))-10.51]}$		100 ^(F) (1-day)	—	---
Thallium		15 ^(C)		0.5 (30-day)	0.24	0.47
Uranium ⁽¹⁷⁾	$e^{(1.1021[\ln(\text{hardness}))+2.7088]}$	$e^{(1.1021[\ln(\text{hardness}))+2.2382]}$		16.8 – 30 ⁽¹³⁾ (30-day)	---	---
Zinc	$0.978 * e^{(0.9094[\ln(\text{hardness}))+0.9095]}$	$0.986 * e^{(0.9094[\ln(\text{hardness}))+0.6235]}$ (sculpin) ⁽¹⁵⁾ = $e^{(2.140[\ln(\text{hardness}))-5.084]}$	2000 ^(B) (30-day)	5,000 ^(F) (30-day)	7,400	26,000

NOTE: Capital letters in parentheses refer to references listed in section 31.16(3); Numbers in parentheses refer to Table III footnote

CDPHE Colorado Department of Public Health and Environment
Hardness dependent dissolved water quality standards will be calculated using the mean value of all samples in the applicable stretch of stream.

Table III – Footnotes

- (1) Metals for aquatic life use are stated as dissolved unless otherwise specified.

Where the hardness-based equations in Table III are applied as table value water quality standards for individual water segments, those equations define the applicable numerical standards. As an aid to persons using this regulation, Table IV provides illustrative examples of approximate metals values associated with a range of hardness levels. This table is provided for informational purposes only.

- (2) Metals for agricultural and domestic uses are stated as total recoverable unless otherwise specified.

- (3) Hardness values to be used in equations are in mg/l as calcium carbonate and shall be no greater than 400 mg/l. The exception is for Al, where the upper cap on calculations is a hardness of 220 mg/l. For permit effluent limit calculations, the hardness values used in calculating the appropriate metal standard should be based on the lower 95 per cent confidence limit of the mean hardness value at the periodic low flow criteria as determined from a regression analysis of site-specific data. Where insufficient site-specific data exists to define the mean hardness value at the periodic low flow criteria, representative regional data shall be used to perform the regression analysis. Where a regression analysis is not possible, a site-specific method should be used, e.g., where hardness data exists without paired flow data, the mean of the hardness during the low flow season established in the permit shall be used. In calculating a hardness value, regression analyses should not be extrapolated past the point that data exist. For determination of standards attainment, where paired metal/hardness data is available, attainment will be determined for individual sampling events. Where paired data is not available, the mean hardness will be used.

- (4) Both acute and chronic numbers adopted as stream standards are levels not to be exceeded more than once every three years on the average.

- (5) Unless the stability of the chromium valence state in receiving waters can be clearly demonstrated, the standard for chromium should be in terms of chromium VI. In no case can the sum of the instream levels of Hexavalent and Trivalent Chromium exceed the water supply standard of 50ug/l total chromium in those waters classified for domestic water use.

- (6) FRV means Final Residue Value and should be expressed as "Total" because many forms of mercury are readily converted to toxic forms under natural conditions. The FRV value of 0.01 ug/liter is the maximum allowed concentration of total mercury in the water that will present bioconcentration or bioaccumulation of methylmercury in edible fish tissue at the U.S. Food and Drug Administration's (FDA) action level of 1 ppm. The FDA action level is intended to protect the average consumer of commercial fish; it is not stratified for sensitive populations who may regularly eat fish.

A 1990 health risk assessment conducted by the Colorado Department of Public Health and Environment indicates that when sensitive subpopulations are considered, methylmercury levels, in sport-caught fish as much as one-fifth lower (0.2 ppm) than the FDA level may pose a health risk.

In waters supporting populations of fish or shellfish with a potential for human consumption, the Commission can adopt the FRV as the stream standard to be applied as a 30-day average. Alternatively, the Commission can adopt site-specific ambient based standards for mercury in accordance with section 31.7(1)(b)(ii) and (iii). When this option is selected by a proponent for a particular segment, information must be presented that (1) ambient water concentrations of total

mercury are detectable and exceed the FRV, (2) that there are detectable levels of mercury in the proponent's discharge and that are contributing to the ambient levels and (3) that concentrations of methylmercury in the fish exposed to these ambient levels do not exceed the maximum levels suggested in the CDH Health Advisory for sensitive populations of humans. Alternatively or in addition the proponent may submit information showing that human consumption of fish from the particular segment is not occurring at a level which poses a risk to the general population and/or sensitive populations.

- (7) Applicable to all Class 1 aquatic life segments which also have a water supply classification or Class 2 aquatic life segments which also have a water supply classification designated by the Commission after rulemaking hearing. These Class 2 segments will generally be those where fish of a catchable size and which are normally consumed are present, and where there is evidence that fishing takes place on a recurring basis. The Commission may also consider additional evidence that may be relevant to a determination whether the conditions applicable to a particular segment are similar enough to the assumptions underlying the water plus fish ingestion criteria to warrant the adoption of water plus fish ingestion standards for the segment in question.
- (8) The use of 0.1 micron pore size filtration for determining dissolved iron is allowed as an option in assessing compliance with the drinking water standard.
- (9) Selenium is a bioaccumulative metal and subject to a range of toxicity values depending upon numerous site-specific variables.
- (10) Applicable to the following segments which do not have a water supply classification: all Class 1 aquatic life segments or Class 2 aquatic life segments designated by the Commission after rulemaking hearing. These class 2 segments will generally be those where fish of a catchable size and which are normally consumed are present, and where there is evidence that fishing takes place on a recurring basis. The Commission may also consider additional evidence that may be relevant to a determination whether the conditions applicable to a particular segment are similar enough to the assumptions underlying the fish ingestion criteria to warrant the adoption of fish ingestion standards for the segment in question.
- (11) Where the pH is equal to or greater than 7.0 in the receiving water after mixing, the chronic hardness-dependent equation will apply. Where pH is less than 7.0 in the receiving water after mixing, either the 87 µg/l chronic total recoverable aluminum criterion or the criterion resulting from the chronic hardness-dependent equation will apply, whichever is more stringent.
- (12) This standard is only appropriate where irrigation water is applied to soils with pH values lower than 6.0.
- (13) Whenever a range of standards is listed and referenced to this footnote, the first number in the range is a strictly health-based value, based on the Commission's established methodology for human health-based standards. The second number in the range is a maximum contaminant level, established under the federal Safe Drinking Water Act that has been determined to be an acceptable level of this chemical in public water supplies, taking treatability and laboratory detection limits into account. Control requirements, such as discharge permit effluent limitations, shall be established using the first number in the range as the ambient water quality target, provided that no effluent limitation shall require an "end-of-pipe" discharge level more restrictive than the second number in the range. Water bodies will be considered in attainment of this standard, and not included on the Section 303(d) List, so long as the existing ambient quality does not exceed the second number in the range.
- (14) The arsenic limit shall be calculated to meet the relevant standard in accordance with the provisions of Section 31.10 of this regulation unless:

- a. The permittee provides documentation that a reasonable level of inquiry demonstrates that there is no actual domestic water supply use of the waters in question or of hydrologically connected ground water, or
 - b. The arsenic concentration at the point of intake to the domestic water supply will not exceed the standard as demonstrated through modeling or other scientifically supportable analysis.
- (15) The chronic zinc equation for sculpin applies in areas where mottled sculpin are expected to occur and hardness is less than 102 ppm CaCO₃. The regular chronic zinc equation applies in areas where mottled sculpin are expected to occur, but the hardness is greater than 102 ppm CaCO₃.
- (16) In determining whether adoption of a molybdenum standard is appropriate for a segment, the Commission will consider whether livestock or irrigated forage is present or expected to be present. The table value assumes that copper and molybdenum concentrations in forage are 7 mg/kg and 0.5 mg/kg respectively, forage intake is 6.8 kg/day, copper concentration in water is 0.008 mg/l, water intake is 54.6 l/day, copper supplementation is 48 mg/day, and that a Cu:Mo ratio of 4:1 is appropriate with a 0.075 mg/l molybdenum margin of safety. Numeric standards different than the table-value may be adopted on a site-specific basis where appropriate justification is presented to the Commission. In evaluating site-specific standards, the relevant factors that should be considered include the presence of livestock or irrigated forage, and the total intake of copper, molybdenum, and sulfur from all sources (i.e., food, water, and dietary supplements). In general, site-specific standards should be based on achieving a safe copper:molybdenum total exposure ratio, with due consideration given to the sulfur exposure. A higher Cu:Mo ratio may be necessary where livestock exposure to sulfur is also high. Species specific information shall be considered where cattle are not the most sensitive species.
- (17) When applying the table value standards for uranium to individual segments, the Commission shall consider the need to maintain radioactive materials at the lowest practical level as required by Section 31.11(2) of the Basic Standards regulation.

Worksheet 17 — Sampling Design and Rationale

(UFP-QAPP Manual Section 3.1.1)

(EPA 2106-G-05 Section 2.3.1)

START will collect surface water samples to characterize water quality and flow impacts from the Gold King Mine release. Surface water will be monitored periodically for pH. Other water quality parameters such as conductivity, turbidity and dissolved oxygen will be measured as long as the additional information is helpful in evaluating site conditions.

Additional media such as sediment, soil and/or groundwater may also be sampled, as directed by the EPA OSC.

This project involves the collection of laboratory samples and field screening. Sample points will be located with a Global Positioning System (GPS) device to be used for mapping purposes and to document sample locations selected in the field. If sampling locations become inaccessible, alternate sampling locations which provide similarly adequate or sufficient data as the original will be identified and sampled based upon the best judgment of the inspector/sampler, if necessary.

Sample Locations and Nomenclature

Sample locations will be identified in the field in coordination with the EPA OSC. In general, the sampling area extends from the Gold King Mine along Cement Creek and then along the Animas River to the New Mexico border. The priority and importance of each sample will be determined by the OSC.

Sample identification will utilize the following nomenclature, unless a previously defined station named exists, in which case the previously defined identification will be utilized. Sample nomenclature will use the following to designate the project: Gold King Mine (GKM) followed by indication of the sample matrix, a sequential sample number, and the date (MMDDYY). Sample matrix identifiers are:

- SW – surface water
- SD – sediment
- GW – groundwater
- TW - tapwater
- SO – soil

If needed, additional identifiers to distinguish other media types may be added. These will be noted by the sampler in the field logbook.

For example, GKMSW04-080915 would designate the surface water sample collected on 8/9/15 from the fourth location. Samples will be recorded in a logbook and GPS coordinates recorded. If site conditions warrant the modification of nomenclature, this change will be documented in the logbook.

Previously identified locations that may be sampled are listed below.

TDD 1508-04, 1509-02

29

September 2015

Sample ID	Sample Location Description	Latitude / Longitude
CC01C	Grand Mogul adit. Sample water from the toe of the waste pile.	37 54 35.72 N 107 37 51.66 W
CC02D	Mogul Mine adit. Sample water downstream of mine pool at the 3 inch flume.	37 54 36.14 N 107 38 17.26 W
CC03D	Red & Bonita mine adit. Sample water at the culvert crossing under the road.	37 53 48.46 N 107 38 41.61 W
CC06	Gold King 7 Level mine adit. Sample water from flow leaving the adit.	37 53 40.50 N 107 38 18.09 W
CC18	Sample water above Gladstone road crossing.	37 53 28.57 N 107 38 57.07 W
CC19	American Tunnel mine adit. Sample flow coming out of the ground.	37 53 27.50 N 107 38 54.39 W
CC48	Cement Creek upstream of confluence with Animas River	37 49 04.07 N 107 39 42.49 W
AR68	Animas River above Cement Creek	37 48 40.34 N 107 39 33.32 W
AR72	Animas River downstream of Silverton	37 47 24.21 N 107 40 03.30 W

Sampling and Field QC Procedures

Samples will be analyzed for the parameters listed on Worksheet 15. Additional parameters may be added if directed by the OSC and Incident Command. Requirements for the sample container, volume, preservation, and QC samples are presented on Worksheet 19 & 30 of the QAPP.

Sampling and analytical activities performed on site will follow all applicable SOPs outlined in Worksheet 21, including EPA ERT SOP 2001 “General Field Sampling Guidelines”. Sampling is anticipated to be performed in Level D personal protective equipment (PPE).

Samples will be collected using equipment and procedures appropriate to the matrix, parameters, and sampling objectives. The volume of the sample collected will be sufficient to perform the analysis requested. Samples will be stored in the proper types of containers and preserved in a manner for the analysis to be performed per laboratory guidelines.

Field water quality parameters will be obtained using a Horiba water quality meter. Field monitoring will be used to measure the quality of water discharged from the treatment system, with emphasis on pH and turbidity measurements. Visual observations of water clarity will be recorded.

Dedicated sampling equipment, sample containers, and PPE will be maintained in a clean, segregated area. Personnel responsible for sampling will change gloves between each sample collection/handling activity. Personnel will use unpowdered nitrile gloves as some types of powder in the powdered gloves contain zinc which could potentially contaminate samples.

START personnel will collect field duplicate and matrix spike/matrix spike duplicate (MS/MSD) samples and QA/QC samples as needed during the sampling activities. QA/QC samples will be collected according to the following dictates and summarized on Worksheet 20:

- Blind field duplicate water samples will be collected during sampling activities at locations selected by the START PTL. The data obtained from these samples will be used to assist in the quality assurance of the sampling procedures and laboratory analytical data by allowing an evaluation of reproducibility of results. Efforts will be made to collect duplicate samples in locations where there is visual evidence of contamination or where contamination is suspected. One duplicate sample will be collected for this sampling activity. In general blind field duplicate samples are collected at the rate of one duplicate for every 10 samples collected.
- Field Blank - Field blanks will be prepared by pouring de-ionized water into pre-cleaned laboratory-grade sample containers for analysis. If samples are field filtered for dissolved metals and mercury, the deionized water will be run through the same type of filtration device as the field samples. These samples will be prepared to demonstrate the impact the surrounding environment is having on the samples being collected. Field blank samples will be collected once per day for this particular scope of work.
- Temperature Blanks - Each sample cooler shall contain a temperature blank. The temperature blank should be supplied by the receiving laboratory and can a plastic bottle filled with water. The purpose of the temperature blank is to document the temperature of the representative solution contained within the same transport cooler as the collected field sample.
- Equipment Rinsate Blanks - Rinsate blanks will be prepared by pouring de-ionized water over non-disposable sampling equipment after it has been decontaminated and by collecting the rinse water in sample containers for analyses. These samples will be prepared to demonstrate that the equipment decontamination procedures for the sampling equipment were performed effectively. It is anticipated that enough pre-cleaned disposable equipment will be available and that the collection of an equipment rinsate blank will not be needed during this sampling event. However if field conditions change, an equipment rinsate blank will be collected following equipment decontamination procedures.
- Matrix spike (MS) samples will be collected during sampling activities at locations selected by the START PTL. The data obtained from these samples will be used to assist in the quality assurance of the laboratory analytical procedure. Matrix spiking ensures that the laboratory is able to extract an acceptable percentage of a spiked constituent. At the direction of EPA, one matrix spike sample may be collected for every 20 samples submitted for analysis. The matrix spiking analysis often duplicates the spiking procedure on a separate sample volume (MSD).

Additional Sampling/Long Term Considerations

Sampling beyond the initial surface water sampling may be required. Tasks that may be required and implemented at the direction of the EPA OSC and the Incident Commander include:

- Sampling via ISCO samplers
- Installation of mini-sipper units at designated stations
- Repeat sampling at surface water stations
- Collection of biotic samples

In addition, START will work with EPA to provide support, as needed, to complementary sampling efforts conducted by other agencies collaborating with EPA on the assessment.

Worksheet 18 — Sampling Locations and Methods

(UFP-QAPP Manual Section 3.1.1 and 3.1.2)

(EPA 2106-G-05 Sections 2.3.1 and 2.3.2)

The following information is project-specific and will be included in the site-specific SAP, and/or QAPP.

Sampling Location / ID	Matrix	Depth (units)	Type	Analyte/Analytical Group	Sampling SOP Reference ¹	Comments
Site ID_mmddyy	Surface Water	TBD	Grab	Metals, Alkalinity, Total Suspended Solids, Total Dissolved Solids, pH		
GKMSW##_mmddyy	Surface Water	TBD	Grab	Metals, Alkalinity, Total Suspended Solids, Total Dissolved Solids, pH		
GKMSD##_mmddyy	Sediment	TBD	Grab/Composite	Metals		
GKMGW##_mmddyy	Groundwater	Unknown	Discrete	Metals, Alkalinity, Total Suspended Solids, Total Dissolved Solids, pH		Groundwater/Well type will be defined by addition of type ID in sample ID nomenclature.

¹ Sampling SOPs references are provided in Worksheet 21.

Site ID is previously defined location ID, if exists.

Worksheet 19 & 30 — Sample Containers, Preservation, and Hold Times

(UFP-QAPP Manual Section 3.1.2.2)

(EPA 2106-G-05 Section 2.3.2)

All analyses will be conducted by a CLP laboratory, the Region 8 CRL, or a WESTON-subcontracted laboratory.

Laboratory (Name, sample receipt address, POC, e-mail, and phone numbers): TestAmerica

List Any Required Accreditations/Certifications: TBD

Back-up Laboratory: TBD

Sample Delivery Method: FedEx

Matrix	Analyte/ Analyte Group	Method/ SOP ¹	Container(s) (number, size & type per sample) ²	Preservation	Preparation Holding Time	Analytical Holding Time	Data Package Turnaround
Sediment	Metals	200.7/200.8/245.1	One 4 ounce glass jar	Store @ < 4°C	180 days	40 days	TBD
Water	Total Metals (including mercury)	200.7/200.8/245.1	One 1-500 mL polyethylene bottle	HNO ₃ to pH < 2 and store @ < 4°C	28 days for mercury, 180 days for all other metals	40 days	TBD
	Dissolved Metals (including mercury)	200.7/200.8/245.1	One 1-500 mL polyethylene bottle	Field Filtered: HNO ₃ to pH < 2 and store @ < 4°C If not field filtered, no preservative	28 days for mercury, 180 days for all other metals	40 days	TBD
	Total Dissolved Solids	SM2540-C	One 1-Liter polyethylene bottles	Store @ < 4°C	7 days	40 days	TBD
	Total Suspended Solids	SM2540-D	One 1-Liter polyethylene bottles	Store @ < 4°C	7 days	40 days	TBD
	pH	SM4500H+B	One 1-Liter polyethylene bottles	Store @ < 4°C	ASAP	40 days	TBD
	Alkalinity	SM2320B	One 500 mL polyethylene bottle	Store @ < 4°C	N/A	24 hours	TBD

¹ Refer to the Analytical SOP References table (Worksheet 23).

² The minimum sample size is based on analysis allowing for sufficient sample for reanalysis. Additional volume is needed for the laboratory MS/MSD sample analysis.

Worksheet 20 — Field Quality Control Sample Summary

(UFP-QAPP Manual Sections 3.1.1 and 3.1.2.)

(EPA 2106-G-05 Section 2.3.5)

Matrix	Analyte/Analytical Group	No. of Field Samples ¹	No. of Field Duplicates	No. of MS/MSD	No. of Field Blanks	No. of Equip. Blanks	No. of Trip Blanks	No. of Other	Total No. of Samples to Laboratory
Surface water	Total Metals	TBD	1 per 10	1 per 20 or 1 per day	1 per 20 or 1 per day	1 per 20 if using non-disposable equipment	0	0	TBD
Surface water	Dissolved Metals	TBS	1 per 10	1 per 20 or 1 per day	1 per 20 or 1 per day	1 per 20 if using non-disposable equipment	0	0	TBD
Groundwater	Total Metals	TBD	1 per 10	1 per 20 or 1 per day	1 per 20 or 1 per day	1 per 20 if using non-disposable equipment	0	0	TBD
Groundwater	Dissolved Metals	TBS	1 per 10	1 per 20 or 1 per day	1 per 20 or 1 per day	1 per 20 if using non-disposable equipment	0	0	TBD
Sediment	Total Metals	TBD	1 per 10	1 per 20 or 1 per day	1 per 20 or 1 per day	1 per 20 if using non-disposable equipment	0	0	TBD

¹ Samples that are collected at different depths at the same location, and analyzed separately, will be counted as separate field samples. Even if they are taken from the same container as the parent field sample, MS/MSDs are counted separately, because they are analyzed separately. If composite samples or incremental samples are collected, only the sample that will be analyzed will be included; subsamples and increments will not be listed separately.

² Total number of samples to the laboratory does not include MS/MSD samples.

Note: If EPA requests that field samples be collected from treatment system water and analyzed for total and dissolved metals, the need for a duplicate will be determined based on the rationale for sampling. The number and types of QC samples will be based on project-specific DQOs and this worksheet will be adapted, as necessary, to accommodate project-specific requirements. Project-specific QC samples may include field duplicate, field blank, equipment blank, trip blank, field split, MS/MSD, and PT samples and will be collected in accordance with the frequencies recorded on QAPP Worksheet 12. Quality Assurance Assessment and Corrective Actions are found in QAPP Worksheet #28.

Worksheet 21 — Field SOPs

(UFP-QAPP Manual Section 3.1.2)

(EPA 2106-G-05 Section 2.3.2)

SOPs may include, but are not limited to, those identified in the table below.

SOP Number or Reference	Title, Revision, Date, and URL (if available)	Originating Organization	SOP Option or Equipment Type (if SOP provides different options)	Modified for Project? Y/N	Comments
2006	Sampling Equipment Decontamination, 6/2011	U.S. EPA, ERT		N	
2007	Groundwater Well Sampling, 6/2011	U.S. EPA, ERT		N	
2012	Soil Sampling, 6/2011	U.S. EPA, ERT		N	
2013	Surface Water Sampling, 6/2011	U.S. EPA, ERT		N	
2016	Sediment Sampling, 6/2011	U.S. EPA, ERT		N	
2017	Waste Pile Sampling, 6/2011	U.S. EPA, ERT		N	
2043	Water Level Measurement, 6/2011	U.S. EPA, ERT		N	
2049	Investigation-Derived Waste (IDW) Management, 6/2011	U.S. EPA, ERT		N	
G-12	Specifications and Guidance for Contaminant-Free Sample Containers, 12/1992	U.S. EPA, Office of Solid Waste and Emergency Response		N	
SS-5	Residential Soil Lead Sampling Guidance, 4/2000	U.S. EPA R8 Superfund Program			
NN2044	Monitoring Well Development, 6/2011	U.S. EPA, ERT		N	
2001	General Field Sampling Guidelines, 6/2011	U.S. EPA, ERT		N	
CDPHE 2010	Standard Operating Procedures for the Collection of Water Samples, 2010 https://www.colorado.gov/pacific/sites/default/files/WQ_nonpoint_source-SOP-Collection-of-Water-Chemistry-Samples-050110.pdf	CDPHE	N	N	
WQCSOP-001	Benthic Macroinvertebrate Sampling Protocols, 2010.	CDPHE		N	

START will review existing information and may conduct sampling for removal/emergency response activities. Environmental samples will be collected for analysis at the EPA Region 8 CRL, ESAT laboratory, or by subcontracted laboratories.

Inclusive of the U.S EPA Region 8 Removal and Emergency Response Program, START may conduct a wetland determination on a site-specific basis in accordance with the methods described in the *Corps of Engineers Wetlands Delineation Manual (USACE 1987, http://www.usace.army.mil/Missions/CivilWorks/RegulatoryProgramandPermits/reg_supp.aspx)*, regional supplemental guidance, and subsequent clarification memoranda. The wetland determination is based on a three-parameter approach that requires evidence of the following wetland indicators: dominant hydrophytic vegetation, hydric soil characteristics, and the presence of wetland hydrology. An area must meet all three wetland indicator criteria (except where noted in the USACE 1987 Supplemental Manuals) to be considered a jurisdictional wetland.

During sampling activities, IDW may be generated. IDW may consist of decontamination fluids, purge/development water, excess sampled media (e.g., soil, sediment, water, etc.), disposable sampling supplies, and PPE (e.g., Tyvek/Saranex coveralls, gloves, booties, etc.). Handling of IDW will be performed according with SOP 2049 as listed above as well as procedures described in *Management of Investigation Derived Wastes during Site Inspections (May 1991)*. Waste disposal for IDW will be dependent upon classification of the waste as either RCRA hazardous or RCRA nonhazardous waste.

Worksheet 22 — Field Equipment Calibration, Maintenance, Testing, and Inspection

(UFP-QAPP Manual Section 3.1.2.4)

(EPA 2106-G-05 Section 2.3.6)

START field personnel are responsible for the calibration of EPA field equipment and field equipment provided by subcontractors. Documented and approved procedures will be used for calibrating measuring and testing equipment. Widely accepted procedures, such as those published by U.S. EPA and ASTM, or procedures provided by manufacturers in equipment manuals will be adopted. Items may include, but are not limited to those identified in the table below.

Field Equipment	Calibration Activity	Maintenance Activity	Testing Activity	Inspection Activity	Frequency	Acceptance Criteria	Corrective Action	Title or Position of Responsible Person	Verification	SOP Reference ¹
Horiba U-50/YSI® 600XLM Water Quality Meters	Calibrate probes with standards per instrument instruction manual	Check batteries, clean probes, store in manufacturer recommended solution	Calibration check	Visually inspect for external damage to probe(s)	Refer to instrument SOP	Refer to instrument SOP	Refer to instrument SOP	Field personnel	WAM/COR	G-13/G-14
Water Level Indicators	Calibrate tape against calibrated steel measuring tape	Clean prior and after each use, check battery	Calibration and operational equipment check	Visually inspect for obvious defects, broken parts, or cleanliness	Prior to use	Equipment operational	Repair/replace as needed	Field personnel	WAM/COR	Instrument-Specific
Sampling Tools (Disposable Scoops)	NA	NA	NA	Visually inspect for obvious defects or broken parts	Prior to use	NA	Replace	Field personnel	WAM/COR	NA
Disposable, inert sample mixing containers	NA	NA	NA	Visually inspect for cleanliness	Prior to use	NA	Replace	Field personnel	WAM/COR	NA
Metal sampling equipment as necessary (trowels)	NA	Clean prior and after each use	NA	Visually inspect for cleanliness	Prior to use	Should be covered from previous decontamination procedure	Perform decontamination procedure again as needed	Field personnel	NA	Metal sampling equipment as necessary (trowels)

Field Equipment	Calibration Activity	Maintenance Activity	Testing Activity	Inspection Activity	Frequency	Acceptance Criteria	Corrective Action	Title or Position of Responsible Person	Verification	SOP Reference ¹
Grundfos Readiflow 2 Submersible Pump	NA	Clean prior and after each use	Operational equipment check	Visually inspect for obvious defects, broken parts, or cleanliness	Prior to use	Equipment operational	Repair/replace as needed	Field personnel	WAM/COR	Instrument-Specific
MiniSipper	Calibrate by method with standard solutions	If poor instrument performance, replace tungsten lamp	Calibration and operational equipment check	Visually inspect for obvious defects, broken parts, or cleanliness	Prior to use	Equipment operational	Repair/replace as needed	Field personnel	WAM/COR	Instrument-Specific
ISCO samplers	Perform volume calibration	Clean pump tubing, suction line, bottles, humidity indicator, and replace batteries	Calibration and operational equipment check	Visually inspect for obvious defects, broken parts, or cleanliness	Prior to use	Equipment operational	Repair/replace as needed	Field personnel	WAM/COR	Instrument-Specific
Sampling Sticks	NA	NA	NA	Visually inspect for obvious defects or broken parts	Prior to use	NA	Replace	Field personnel	WAM/COR	NA

¹ Refer to Field SOPs (Worksheet 21) and Analytical SOPs (Worksheet 23).

Worksheet 23 — Analytical SOPs

(UFP-QAPP Manual Section 3.2.1)

(EPA 2106-G-05 Section 2.3.4)

Items may include, but are not limited to those identified in the table below.

Lab SOP Number ¹	Title, Revision Date, and/or Number and URL (if available)	Screening or Definitive Data	Matrix/Analytical Group	SOP Option or Equipment Type	Modified for Project? (Y/N)
TBD	METHOD 200.7 DETERMINATION OF METALS AND TRACE ELEMENTS IN WATER AND WASTES BY INDUCTIVELY COUPLED PLASMA-ATOMIC EMISSION SPECTROMETRY, 1994, http://water.epa.gov/scitech/methods/cwa/bioindicators/upload/2007_07_10_methods_method_200_7.pdf	Definitive	Water/Soil	ICP-AES	TBD
TBD	METHOD 200.8 DETERMINATION OF TRACE ELEMENTS IN WATERS AND WASTES BY INDUCTIVELY COUPLED PLASMA - MASS SPECTROMETRY, 1994, http://water.epa.gov/scitech/methods/cwa/bioindicators/upload/2007_07_10_methods_method_200_8.pdf	Definitive	Water/Soil	ICP-MS	TBD
TBD	METHOD 245.1 Mercury (Manual Cold Vapor Technique) http://www.bucksci.com/catalogs/245_1.pdf	Definitive	Water/Soil	CVAA	TBD
TBD	METHOD SM 2540 D Low Level Total Suspended Solids Dried at 103-105 Deg C 20th Ed. http://www.standardmethods.org/store/ProductView.cfm?ProductID=63	Definitive	Water/Soil	Gravimetry	TBD
TBD	METHOD SM 2540 C Low Level Total Dissolved Solids Dried at 103-105 Deg C 20th Ed. http://www.standardmethods.org/Store/ProductList.cfm	Definitive	Water/Soil	Gravimetry	TBD
TBD	METHOD SM 4500H+B pH Value in Water by Potentiometry Using a Standard Hydrogen Electrode. http://standardmethods.org/	Definitive	Water/Soil	pH Meter	TBD

Worksheet 23 — Analytical SOPs (Continued)

(UFP-QAPP Manual Section 3.2.1)

(EPA 2106-G-05 Section 2.3.4)

Lab SOP Number ¹	Title, Revision Date, and/or Number and URL (if available)	Screening or Definitive Data	Matrix/Analytical Group	SOP Option or Equipment Type	Modified for Project? (Y/N)
SOM01.2	U.S. EPA CLP Statement of Work for Organic Analysis, SOM01.1, 5/2005, http://www.epa.gov/superfund/programs/clp/download/som/som11a-c.pdf MODIFICATIONS UPDATING SOM01.1 TO SOM01.2, 4/2007, http://www.epa.gov/superfund/programs/clp/download/som/som11tosom12mods.pdf	Definitive	Soil, sediment, debris, water, aquatic animal tissue/VOCs, SVOCs, Pesticides, Aroclors	Analyte specific	TBD
ISM01.3	U.S. EPA CLP Statement of Work for Inorganic Analysis, ISM01.2, 1/2010, http://www.epa.gov/superfund/programs/clp/download/ism/ism12a-c.pdf MODIFICATIONS UPDATING ISM01.2 TO ISM01.3, http://www.epa.gov/superfund/programs/clp/download/ism/ism12toism13mods.pdf	Definitive	Soil, sediment, debris, water, aquatic animal tissue/Metals and cyanide	Analyte specific	TBD

¹ Lab SOP numbers are lab-specific and will be identified in the site-specific SAP, and/or QAPP.

Worksheet 24 — Analytical Instrument Calibration

(UFP-QAPP Manual Section 3.2.2)

(EPA 2106-G-05 Section 2.3.6)

As stated in Worksheet 22, START field personnel are responsible for the calibration of EPA and sub-contractor provided analytical field equipment. Documented and approved procedures will be used for calibrating measuring and testing equipment. Widely accepted procedures, such as those published by U.S. EPA and ASTM, or procedures provided by manufacturers in equipment manuals will be adopted.

The responsibility for the calibration of laboratory equipment rests with the selected laboratories. Each type of instrumentation and each U.S. EPA-approved method have specific requirements for the calibration procedures, depending on the analytes of interest and the sample medium. The calibration procedures and frequencies of the equipment used to perform the analyses will be in accordance with requirements established by the U.S. EPA. The laboratory QA manager will be responsible for ensuring that the laboratory instrumentation is maintained in accordance with specifications. Individual laboratory SOPs will be followed for corrective actions and preventative maintenance frequencies. Laboratory quality control, calibration procedures, corrective action procedures, and instrument preventative maintenance will be included in an addendum to this QAPP once the laboratories have been selected for each of the TBA sites. Items may include, but are not limited to those identified in the table below.

Instrument	Calibration Procedure	Frequency of Calibration	Acceptance Criteria	Corrective Action (CA)	Title/Position Responsible for CA	SOP Reference ¹
CVAA	200.7/200.8/245.1	Daily initial calibration prior to sample analysis. Perform instrument re-calibration once per year minimum.	$R^2 \geq 0.995$ for linear regression	Correct problem then repeat initial calibration. If calibration fails again, re-digest the entire digestion batch.	Lab Manager/ Analyst	200.7/200.8/245.1

Instrument	Calibration Procedure	Frequency of Calibration	Acceptance Criteria	Corrective Action (CA)	Title/Position Responsible for CA	SOP Reference ¹
ICP-AES	200.7/200.8/245.1	Calibration and initial calibration verification after instrument set up, then daily; continuing calibration verifications. Upper range within 10%. New upper range limits should be determined whenever a significant change in instrument response or every six months. Low-level continuing calibration verification (LLCCV) standard with 30%.	Initial and continuing calibration verification within $\pm 10\%$ of upper range true values and $\pm 30\%$ LLCCV true values.	Inspect system; correct problem; re-run calibration and affected samples	Lab Manager/Analyst	200.7/200.8/245.1
ICP/ ICP-MS	200.7/200.8/245.1	Calibration and initial calibration verification after instrument set up, then daily; continuing calibration verification 10% or every 2 hours, whichever is more frequent	Calibration $r^2 > 0.995$; initial and continuing calibration verification within $\pm 20\%$ of true values	Inspect system; correct problem; re-run calibration and affected samples	Lab Manager/Analyst	200.7/200.8/245.1

¹ Refer to the Analytical SOPs table (Worksheet 23).

Worksheet 25 — Analytical Instrument and Equipment Maintenance, Testing, and Inspection

(UFP-QAPP Manual Section 3.2.3)

(EPA 2106-G-05 Section 2.3.6)

All laboratories conducting analyses of samples collected under the contract are required to have a preventative maintenance program covering testing, inspection, and maintenance procedures and schedule for each measurement system and required support activity. The basic requirements and components of such a program include the following:

Instrument/ Equipment	Maintenance Activity	Testing Activity	Inspection Activity	Frequency	Acceptance Criteria	Corrective Action (CA)	Title/ Position Responsible for CA	SOP Reference ¹
CVAA	Replace disposables, flush lines, check lamp current and gas flow	Sensitivity check	Instrument performance and sensitivity	Daily or as needed	CCV pass criteria	Recalibrate	Analyst	200.7/200.8/245.1
ICP-AES	Replace disposable, flush lines, and clean autosampler	Analytical standards	Instrument performance and sensitivity	Daily or as needed	CCV pass criteria	Recalibrate	Analyst	200.7/200.8/245.1
ICP/ICP-MS	Replace pump windings and gas tanks, check standard and sample flow	Monitor instrument standard (ISTD) counts for variation	Instrument performance and sensitivity	As needed	Monitor ISTD counts for variation	Replace windings, recalibrate and reanalyze	Analyst	200.7/200.8/245.1

¹ Refer to the Analytical SOPs table (Worksheet 23). A laboratory-specific QA Manual may be referenced on a project-specific basis and will be identified in the site specific SAP, and/or QAPP.

Worksheet 26 & 27 — Sample Handling, Custody, and Disposal

(UFP-QAPP Manual Section 3.3)

(EPA 2106-G-05 Manual Section 2.3.3)

Examples of field form (Appendix F), chain-of-custody (Appendix G), and sample label and custody seal (Appendix H) documentation are attached. SOPs for sample handling (identified in the table below) are located in Appendix I.

Sampling Organization: WESTON

Laboratory: Project-Specific - TBD

Method of sample delivery (shipper/carrier): Project-Specific - TBD

Number of days from reporting until sample disposal: Project-Specific - TBD

Activity	Organization and Title or Position of Person Responsible for the Activity	SOP Reference
Sample Labeling	Field Personnel	SOP G-1 & G-3
Chain-of-Custody Form Completion	Field Personnel	SOP G-8
Sample Packaging	Field Personnel	SOP G-9
Shipping Coordination	Field Personnel	SOP G-9
Sample Receipt, Inspection, & Log-in	Laboratory Sample Custodian	TBD – Per Laboratory SOP
Sample Custody and Storage	Laboratory Sample Custodian /Laboratory Analytical Personnel	TBD – Per Laboratory SOP
Sample Disposal	Field Personnel/Laboratory Sample Custodian /Laboratory Analytical Personnel	SOP G-1 & G-3/ TBD – Per Laboratory SOP

Supplies and consumables can be received at a START office, U.S. EPA Warehouse or at a site. When supplies are received at a START office or U.S. EPA Warehouse, the PM or PTL will sort the supplies according to vendor, check packing slips against purchase orders, and inspect the condition of all supplies before the supplies are accepted for use on a project. If the supplies do not meet the acceptance criteria, deficiencies will be noted on the packing slip and purchase order. The item will then be returned to the vendor for replacement or repair.

Procedures for receiving supplies and consumables in the field are similar to those described above. Upon receipt, items will be inspected by the START PM or PTL against the acceptance criteria. Any deficiencies or problems will be noted in the field logbook, and deficient items will be returned for immediate replacement.

Worksheet 28 — Analytical Quality Control and Corrective Action

(UFP-QAPP Manual Section 3.4 and Tables 4, 5, and 6)

(EPA 2106-G-05 Section 2.3.5)

The following information is laboratory-specific. The following are typical examples for Organics and Inorganics for all media.

Matrix: All

Analytical Group: All

Analytical Method/SOP: All/All

QC Sample	Number/Frequency	Method/SOP QC Acceptance Limits ¹	Corrective Action	Title/Position of Person Responsible for Corrective Action	Project-Specific MPC
Method Blank	1/Batch (20 samples)	No Target Compounds >1/2 RL; no common lab contaminants >RL.	If sufficient sample is available, reanalyze samples. Qualify data as needed. Report results if sample results >10x blank result or sample results non-detect (ND).	Analyst / Section Supervisor	No Target Compounds >1/2 RL; no common lab contaminants >RL.
LCS	1/Batch (20 samples)	Analyte-specific	If sufficient sample is available, reanalyze samples. Qualify data as needed.	Analyst / Section Supervisor	Laboratory % Recovery Control Limits
MS/MSD	1/Batch (20 samples)	Analyte-specific	Determine root cause; flag MS/MSD data; discuss in narrative.	Analyst / Section Supervisor	Laboratory % Recovery / RPD Control Limits
Surrogates	Every sample	Refer to the laboratory-specific QA Manual and/or the U.S. EPA National Functional Guidelines for Organic Data Review Table Surrogate control limits	Check calculations and instrument performance; recalculate, reanalyze.	Analyst / Section Supervisor	Laboratory % Recovery Control Limits
Dilution Test	One per preparatory batch	1:5 dilution must agree within ±10% of the original determination	Perform post digestion spike addition	Analyst / Section Supervisor	Only applicable for samples with concentrations > 50x Limit of Detection (LOD)

Field and laboratory QC samples and measurements will be used to verify that analytical data meet project-specific MPC, which are based on Project Quality Objectives (PQOs)/DQOs. Field QC samples and measurements and laboratory QC samples will be used to assess how they influence data quality. The project-specific SAP, and/or QAPP will include the information presented in the table above for each sampling technique, analytical method/SOP, matrix, and analytical group. See Worksheet 12 and 20 for descriptions of QC samples, DQIs, and MPC.

Worksheet 29 — Project Documents and Records

(UFP-QAPP Manual Section 3.5.1)

(EPA 2106-G-05 Section 2.2.8)

All records will be generated and verified by START personnel only, stored electronically on the START server and backed up daily. All hard and electronic copies of finalized documents and technical project documents (including but not limited to the QAPP, HASP, etc.) will be retained in accordance with Section H.20 of Contract No.: EP-S8-13-01. Other project-related files, such as contract documents, employee benefits, and other information will be retained in accordance with WESTON Policies and Procedures.

Sample Collection and Field Records			
Record	Generation	Verification	Storage Location/Archival
Field Logbook or Data Collection Sheets	PTL/Field Scientist	Delegated QA Manager	Project File
Chain-of-Custody (COC) Forms	PTL/Field Scientist	Delegated QA Manager	Project File
Custody Seals	PTL/Field Scientist	Delegated QA Manager	Project File
Air Bills	PTL/Field Scientist	Delegated QA Manager	Project File
Daily QC Reports	PTL	Delegated QA Manager	Project File
Deviations	PTL/Field Scientist	Delegated QA Manager	Project File
Corrective Action Reports	Delegated QA Manager	PM	Project File
Correspondence	PTL	Delegated QA Manager	Project File
Field Sample Results/Measurements	PTL/Field Scientist	Delegated QA Manager	Project File
Tailgate Safety Meeting Items	PTL/Field Safety Officer	Delegated QA Manager	Project File

Project Assessments			
Record	Generation	Verification	Storage Location/Archival
Field Analysis Audit Checklist	Delegated QA Manager	PM	Project File
Fixed Laboratory Audit Checklist	Delegated QA Manager	PM	Project File
Data Verification Checklists	Delegated QA Manager	PM	Project File
Data Validation Report	Delegated QA Manager	PM	Project File
Data Usability Assessment Report	Delegated QA Manager	PM	Project File
Corrective Action Reports	Delegated QA Manager	PM	Project File
Correspondence	Delegated QA Manager	PM	Project File

Worksheet 29 — Project Documents and Records (Continued)

(UFP-QAPP Manual Section 3.5.1)

(EPA 2106-G-05 Section 2.2.8)

Laboratory Records			
Record	Generation	Verification	Storage Location/Archival
Sample Receipt, Custody, and Checklist	Laboratory Sample Receiving	Laboratory PM/Delegated QA Manager	Laboratory and Project File
Equipment Calibration Logs	Laboratory Technician	Laboratory PM/Delegated QA Manager	Laboratory and Project File
Standard Traceability Logs	Laboratory Technician	Laboratory PM/Delegated QA Manager	Laboratory and Project File
Sample Prep Logs	Laboratory Technician	Laboratory PM/Delegated QA Manager	Laboratory and Project File
Run Logs	Laboratory Technician	Laboratory PM/Delegated QA Manager	Laboratory and Project File
Equipment Maintenance, Testing, and Inspection Logs	Laboratory Technician/ Laboratory QA Manager	Laboratory PM/Delegated QA Manager	Laboratory and Project File
Corrective Action Reports	Laboratory QA Manager	Laboratory PM/Delegated QA Manager	Laboratory and Project File
Laboratory Analytical Results	Laboratory Technician/ Laboratory QA Manager	Laboratory PM/Delegated QA Manager	Laboratory and Project File
Laboratory QC Samples, Standards, and Checks	Laboratory Technician/ Laboratory QA Manager	Laboratory PM/Delegated QA Manager	Laboratory and Project File
Instrument Results (raw data) for Primary Samples, Standards, QC Checks, and QC Samples	Laboratory Technician/ Laboratory QA Manager	Laboratory PM/Delegated QA Manager	Laboratory and Project File
Sample Disposal Records	Laboratory Technician	Laboratory PM/Delegated QA Manager	Laboratory and Project File

Worksheet 29 — Project Documents and Records (Continued)

(UFP-QAPP Manual Section 3.5.1)

(EPA 2106-G-05 Section 2.2.8)

Laboratory Data Deliverables ¹						
Record	VOCs	SVOCs	PCBs	Pesticides	Metals	Other
Narrative						
COC						
Summary Results						
QC Results						
Chromatograms						
Tentatively Identified Compounds						

¹ The Laboratory Data Deliverables table is designed to be a checklist for use in supporting data completeness. The records and analytical groups in this table are not all inclusive of those that may be used on a specific project and should be modified and utilized by the Delegated QA Manager as applicable.

Worksheet 31, 32 & 33 — Assessments and Corrective Action

(UFP-QAPP Manual Sections 4.1.1 and 4.1.2)

(EPA 2106-G-05 Section 2.4 and 2.5.5)

All reports will be prepared by WESTON and distributed to the following to include but not be limited to the WESTON PM, Program Manager and Delegated QA Manager, and the U.S. EPA COR, WAM, and DAO as applicable.

Assessment Type	Responsible Party & Organization	Number/ Frequency	Estimated Dates	Assessment Deliverable	Deliverable Due Date
Laboratory TSA ²	DAO/WAM/COR EPA Laboratory QA Manager TBD Delegated QA Manager WESTON	CLP, CRL, and certified sub-contract laboratories are routinely audited by accrediting authorities. The laboratory QA manager and/or WESTON Delegated QA Manager will perform audits on a project-specific basis as needed	TBD	Analytical TSA Memorandum and Checklist	TBD
Management Review	DAO/WAM/COR EPA Delegated QA Manager and PM WESTON	1/year	TBD	QA Management Report	TBD
Corrective Action	DAO/WAM/COR EPA Delegated QA Manager and PM WESTON	TBD	TBD	Corrective Action Reports	TBD
Data Validation	Chemist WESTON	TBD	TBD	Data Validation Report	TBD
Contract Closeout	Program Manager WESTON	1	TBD	Contract Closeout Report	TBD

¹ Field sampling TSAs may include, but are not limited to the following: sample collection records; sample handling, preservation, packaging, shipping, and custody records; equipment operation, maintenance, and calibration records.

² Laboratory TSAs may include, but are not limited to the following: sample log-in, identification, storage, tracking, and custody procedures; sample and standards preparation procedures; availability of analytical instruments; analytical instrument operation, maintenance, and calibration records; laboratory security procedures; qualifications of analysts; case file organization and data handling procedures.

Worksheet 34 — Data Verification and Validation Inputs

(UFP-QAPP Manual Section 5.2.1 and Table 9)

(EPA 2106-G-05 Section 2.5.1)

The following information will be used during data verification and validation. Inputs may include, but are not limited to those identified in the table below.

Item	Description	Verification (completeness)	Validation (conformance to specifications)
Planning Documents/Records			
1	Approved QAPP	X	
2	Contract	X	
3	Field SOPs	X	
4	Laboratory SOPs	X	
5	Laboratory QA Manual	X	
6	Laboratory Certifications	X	
Field Records			
7	Field Logbooks	X	X
8	Equipment Calibration Records	X	X
9	COC Forms	X	X
10	Sampling Diagrams/Surveys	X	X
11	Drilling Logs	X	X
12	Geophysics Reports	X	X
13	Relevant Correspondence	X	X
14	Change Orders/Deviations	X	X
15	Field Audit Reports	X	X
16	Field Corrective Action Reports	X	X
17	Sample Location Verification (Worksheet 18)	X	X
Analytical Data Package			
18	Cover Sheet (laboratory identifying information)	X	X
19	Case Narrative	X	X
20	Internal Laboratory COC	X	X
21	Sample Receipt Records	X	X
22	Sample Chronology (i.e. dates and times of receipt, preparation, & analysis)	X	X
23	Communication Records	X	X
24	Project-specific PT Sample Results	X	X
25	LOD/LOQ Establishment and Verification	X	X
26	Standards Traceability	X	X
27	Instrument Calibration Records	X	X
28	Definition of Laboratory Qualifiers	X	X
29	Results Reporting Forms	X	X
30	QC Sample Results	X	X
31	Corrective Action Reports	X	X
32	Raw Data	X	X
33	Electronic Data Deliverable	X	X

This page intentionally left blank.

Worksheet 35 — Data Verification Procedures

(UFP-QAPP Manual Section 5.2.2)

(EPA 2106-G-05 Section 2.5.1)

The following information may include, but are not limited to those identified in the table below.

Records Reviewed	Required Documents	Process Description	Responsible Person, Organization
Approved QAPP	Programmatic and site-specific SAP, and/or QAPP, Contract	Verify completeness, correctness, and contractual compliance of all project QA/QC and data set against the methods, SOPs, and contract requirements conforms.	Jan Christner, P.E., WESTON Cecilia H. Shappee, P.E., WESTON David Robinson, WESTON, TBD
Field SOPs	Programmatic and site-specific SAP, and/or QAPP, SOPs	Ensure that all field sampling SOPs were followed.	Jan Christner, P.E., WESTON
Analytical SOPs	Programmatic and site-specific SAP, and/or QAPP, SOPs	Ensure that all laboratory analytical SOPs were followed.	Tana Jones, PMP, WESTON Laboratory PM, TBD
Field Logbook, Field Sheets, Sample Diagrams/ Surveys	Programmatic and site-specific SAP, and/or QAPP	Verify that records are present and complete for each day of field activities. Verify that all planned samples including field QC samples were collected and that sample collection locations are documented. Verify that meteorological data were provided for each day of field activities. Verify that changes/exceptions are documented and were reported in accordance with requirements. Verify that any required field monitoring was performed and results are documented.	Jan Christner, P.E., WESTON
Equipment Calibration Records	Programmatic and site-specific SAP, and/or QAPP, SOPs, field logbook	Ensure that all field analytical instrumentation SOPs and laboratory analytical SOPs for equipment calibration were followed.	Tana Jones, PMP, WESTON Laboratory PM, TBD

Worksheet 35 — Data Verification Procedures (Continued)

(UFP-QAPP Manual Section 5.2.2)

(EPA 2106-G-05 Section 2.5.1)

Records Reviewed	Required Documents	Process Description	Responsible Person, Organization
COC Forms	Programmatic and site-specific SAP, and/or QAPP	Verify the completeness of COC records. Examine entries for consistency with the field logbook. Check that appropriate methods and sample preservation have been recorded. Verify that the required volume of sample has been collected and that sufficient sample volume is available for QC samples (e.g., MS/MSD). Verify that all required signatures and dates are present. Check for transcription errors.	Jan Christner, P.E., WESTON Laboratory PM, TBD
Relevant reports, and correspondence	Programmatic and site-specific SAP, and/or QAPP	Verify that reports are present and complete for each day of field activities. Verify that correspondence are documented and were reported in accordance with requirements.	Jan Christner, P.E., WESTON
Laboratory Deliverable	Programmatic and site-specific SAP, and/or QAPP	Verify that the laboratory deliverable contains all records specified in the QAPP. Check sample receipt records to ensure sample condition upon receipt was noted, and any missing/broken sample containers were noted and reported according to plan. Compare the data package with COCs to verify that results were provided for all collected samples. Review the narrative to ensure all QC exceptions are described. Check for evidence that any required notifications were provided to project personnel as specified in the QAPP. Verify that necessary signatures and dates are present.	Jan Christner, P.E., WESTON Moira Pryhoda, WESTON
Audit Reports, Corrective Action Reports	Programmatic and site-specific SAP, and/or QAPP	Verify that all planned audits were conducted. Examine audit reports. For any deficiencies noted, verify that corrective action was implemented according to plan.	Jan Christner, P.E., WESTON Moira Pryhoda, WESTON Laboratory PM, TBD

Worksheet 36 — Data Validation Procedures

(UFP-QAPP Manual Section 5.2.2)

(EPA 2106-G-05 Section 2.5.1)

Data Validator: START

Analytical Group/ Method	Data Deliverable Requirements	Analytical Specifications	MPC	Percent of Data Packages to be Validated	Percent of Raw Data Reviewed	Percent of Results to be Recalculated	Validation Procedure	Validation Code ¹	Electronic Validation Program/ Version
Total and Dissolved Metals	Scribe Compatible EDD	QAPP Worksheet 28	Worksheets 11, 12, 19 & 30	10%	0%	0%	U.S. EPA Stage 2A	SV2aE	N/A

¹ Validation Codes are provided in Appendix M.

Validation will be performed on all laboratory analytical data unless a defined quantity or percentage of samples is identified by the U.S. EPA in the Technical Direction Document or during the project scoping meeting on a project-specific basis. Project validation criteria as per QAPP Worksheets 12, 15, 19 & 30, 28, and 36, and cited EPA SW-846 methodology will be used. WESTON-contracted laboratory data packages will be verified and validated using a Stage 2A validation, as described in the EPA *Guidance for Labeling Externally Validated Laboratory Analytical Data for Superfund Use* (January 2009) (Appendix J) unless otherwise specified by the U.S. EPA WAM/COR during the development of the DQOs. Validation Qualifiers will be applied using the following hierarchy: Region 8 UFP-QAPP for Removal Actions and Emergency Responses; the site-specific SAP, and/or QAPP; *EPA National Functional Guidelines for Organic Data Review* (Appendix K); *EPA National Functional Guidelines for Inorganic Data Review* (Appendix L); EPA Publication SW-846; and the laboratory-specific SOP. Methods for which no data validation guidelines exist will be validated following the guidance deemed most appropriate by the data validator.

The data validator will receive all laboratory packages and analytical results electronically. Additionally, the validator will be required to submit final validation reports via PDF format and must provide an annotated laboratory analytical result electronic data deliverable (EDD) with applicable data validation qualifiers (Appendix M) identified in the site-specific SAP, and/or QAPP, and/or result value modifications. The Delegated QA Manager will use EPA document *Using Qualified Data to Document an Observed Release and Observed Contamination* (July 1996) to aid in determining the use of qualified data to document all observed release and observed contamination by chemical analysis under U.S. EPA's HRS. Approved data will be released by the Delegated QA Manager for reporting.

This page intentionally left blank.

Worksheet 37 — Data Usability Assessment

(UFP-QAPP Manual Section 5.2.3 and Table 12)

(EPA 2106-G-05 Section 2.5.2, 2.5.3, and 2.5.4)

Personnel (organization and position/title) responsible for participating in the data usability assessment may include, but not be limited to:

- START PM;
- START Delegated QA Manager;
- START Risk Assessor;
- START Chemist;
- START PTL;
- START Statistician.

Based on project-specific oversight responsibilities and analytical scopes, this data usability assessment worksheet outlines the approach that will be taken as the analytical scope expands on a project-specific basis. The following general steps will be followed to assure that the data usability assessment evaluates whether underlying assumptions used during systematic planning are supported, sources of uncertainty have been accounted for and are acceptable, data are representative of the population of interest, and the results can be used as intended, with the acceptable level of confidence:

- Step 1 – Review the project’s objectives and sampling design;
- Step 2 – Review the data verification and data validation outputs;
- Step 3 – Verify the assumptions of the selected statistical method;
- Step 4 - Implement the statistical method;
- Step 5 – Document data usability and draw conclusions.

The data usability assessment is considered the final step in the data evaluation process; all data will be assessed for usability, regardless of the data evaluation/validation process implementation. Data usability goes beyond validation in that it evaluates the achievement of the DQOs based on the comparison of the project DQIs and individual study-specific work plans, with the obtained results. The results of the data usability assessment, and particularly any changes to the DQOs necessitated by the data not meeting usability criteria, will be reported in accordance with Worksheet 6.

Primarily, the assessment of the usability will follow procedures described in appropriate EPA guidance documents, particularly *Guidance for Data Usability in Risk Assessment* (Publication No. 9285.7-05FS, September 1992)(Appendix U), and will be conducted according to the process outlined below.

- 1. Sampling and Analysis Activities Evaluation:** The first part of the data usability evaluation will include a review of the sampling and analysis activities in comparison to project-specific DQIs and study-specific work plans. Specific limitations to the data (i.e., results that are qualified as estimated [J/UJ], or rejected [R], will be determined and documented in the database).

Worksheet 37 — Data Usability Assessment (Continued)

(UFP-QAPP Manual Section 5.2.3 and Table 12)

(EPA 2106-G-05 Section 2.5.2, 2.5.3, and 2.5.4)

- 2. Achievement of DQIs:** The second part of data usability pertains to the achievement of the program-specific DQIs. Each investigator will compare the performance achieved for each data quality criterion against the expected and planned performance. In general, this comparison will follow from the DQIs used to define each DQO. This comparison is the most critical component of the assessment process. Any deviation from planned performance will be documented and evaluated to determine whether corrective action is advisable. Potential corrective actions will range from re-sampling and/or reanalysis of data, to qualification or exclusion of the data for use in the data interpretation. In the event that corrective action is not possible, the limitations, if any, of the data with regard to achieving the DQOs will be noted.

In conjunction with the DQI achievement review, the investigators will need to make decisions for the use of qualified values, which are a consequence of the formalized evaluation/validation process. Data qualifiers will be applied to individual data results. Data usability decisions will be made based on the assessment of the usability of each of these results for the intended purpose. Evaluation will describe the uncertainty (bias, imprecision, etc.) of the qualified results. Cumulative QC exceedances from the DQIs may require technical judgment to determine the overall effect on the usability of the data. Decisions about usability of qualified data for use in risk assessment will be based on the EPA document mentioned, which allows for the use of estimated values. Finally, data users may choose to determine final data usability qualifiers as a result of this overall examination and decision process.

- 3. Achievement of DQOs:** The final part in the data usability process concerns achievement of the DQOs. Once the data set has been assessed to be of known quality, data limitations have been documented, and overall result applicability/usability for its intended purpose has been determined, the final data assessment can be initiated by considering the answers to the following questions:
 - Are the data adequate to determine the extent to which hazardous substances have migrated or to what extent they were expected to migrate from potential hazardous substance source areas?
 - Do the data collected adequately characterize the nature and extent of potential hazardous substance source areas at the site?
 - Are the data statistically adequate to evaluate on a per chemical and per media basis?
 - Do the data collected allow assessment of hydrogeologic factors, which may influence contaminant migration/distribution?
 - Do laboratory reporting limits attain the applicable state and/or federal standards and/or screening levels?
 - Is the sample set sufficient to develop site-specific removal and disposal treatment methodologies?

Worksheet 37 — Data Usability Assessment (Continued)

(UFP-QAPP Manual Section 5.2.3 and Table 12)

(EPA 2106-G-05 Section 2.5.2, 2.5.3, and 2.5.4)

- Have sufficient data been collected to evaluate how factors including physical characteristics of the site and climate and water table fluctuations affect contaminant fate and transport?
- Have sufficient data been collected to determine the toxicity, environmental fate, and other significant characteristics of each hazardous substance present?
- Is the data set sufficient to evaluate the potential extent and risk of future releases of hazardous substances, which may remain as residual contamination at the source facility?

Principal investigators, in conjunction with the project team, will formulate solutions if data gaps are found as a result of problems, biases, trends, etc., in the analytical data, or if conditions exist that were not anticipated in the development of the DQOs. It is particularly important that each data usability evaluation specifically address any limitations on the use of the data that may result from a failure to achieve the stipulated DQO.

If the project scope changes, the DQOs will be expanded. The DQOs will address the specific action limits and measurable performance criteria, in order to make appropriate decisions on the analytical data.

DQIs, such as precision, accuracy, completeness, representativeness, and comparability measurements, aid in the evaluation process and are discussed below.

Precision

The most commonly used estimates of precision are the RPD for cases in which only two measurements are available, and the percent RSD (%RSD) when three or more measurements are available. This is especially useful in normalizing environmental measurements to determine acceptability ranges for precision because it effectively corrects for the wide variability in sample analyte concentration indigenous to samples.

Precision is represented as the RPD between measurement of an analyte in duplicate samples or in duplicate spikes. RPD is defined as follows:

$$\text{RPD} = \frac{|C_1 - C_2|}{\frac{C_1 + C_2}{2}} \times 100$$

Where:

C_1 = First measurement value

C_2 = Second measurement value

For field measurements such as pH, where the absolute variation is more appropriate, precision is often reported as the absolute range (D) of duplicate measurements:

$$\%D = m1 - m2$$

Worksheet 37 — Data Usability Assessment (Continued)

(UFP-QAPP Manual Section 5.2.3 and Table 12)

(EPA 2106-G-05 Section 2.5.2, 2.5.3, and 2.5.4)

Where:

m_1 = First measurement value

m_2 = Second measurement value

The % RSD is calculated by the standard deviation of the analytical results of the replicate determinations relative to the average of those results for a given analyte. This method of precision measurement can be expressed by the formula:

$$\%RSD = \frac{\sqrt{\sum_{i=1}^N \left(\frac{RF_i - RF}{N-1} \right)^2}}{RF} \times 100$$

Where:

RF = Response factor

N = Number of measurements

Precision control limits for evaluation of sample results are established by the analysis of control samples. The control samples can be method blanks fortified with surrogates (e.g., for organics), or LCS purchased commercially or prepared at the laboratory. The LCS is typically identified as blank spikes (BS) for organic analyses. For multi-analyte methods, the LCS or BS may contain only a representative number of target analytes rather than the full list.

The RPD for duplicate investigative sample analysis provides a tool for evaluating how well the method performed for the respective matrix.

Accuracy/Bias

Accuracy control limits are established by the analysis of control samples, which are in water and/or solid/waste matrices. For organic analyses, the LCS may be a surrogate compound in the blank or a select number of target analytes in the blank spike. The LCS is subjected to all sample preparation steps. When available, a solid LCS may be analyzed to demonstrate control of the analysis for soil. The amount of each analyte recovered in an LCS analysis is recorded and entered into a database to generate statistical control limits. These empirical data are compared with available method reference criteria and available databases to establish control criteria.

The %R for spiked investigative sample analysis (e.g., matrix spike) provides a tool for evaluating how well the method worked for the respective matrix. These values are used to assess a reported result within the context of the project data quality objectives. For results that are outside control limits provided as requirements in the QAPP, corrective action appropriate to the project will be taken and the deviation will be noted in the case narrative accompanying the sample results. Percent recovery (%R) is defined as follows:

$$\%Recovery = \frac{(A_T - A_0)}{A_F} \times 100$$

Where:

Worksheet 37 — Data Usability Assessment (Continued)

(UFP-QAPP Manual Section 5.2.3 and Table 12)

(EPA 2106-G-05 Section 2.5.2, 2.5.3, and 2.5.4)

A_T = Total amount recovered in fortified sample

A_0 = Amount recovered in unfortified sample

A_F = Amount added to sample

Accuracy for some procedures is evaluated as the degree of agreement between a new set of results and a historical database or a table of acceptable criteria for a given parameter. This is measured as percent difference (%D) from the reference value, and is primarily used by the laboratory as a means for documenting acceptability of continuing calibration.

The %D is calculated by expressing, as a percentage, the difference between the original value and new value relative to the original value. This method for precision measurement can be expressed by the formula:

$$\%D = \frac{C_1 - C_2}{C_1} \times 100$$

Where:

C_1 = Concentration of analyte in the initial aliquot of the sample.

C_2 = Concentration of analyte in replicate.

The laboratory will review the QC samples and surrogate recoveries for each analysis to ensure that the %R lies within the control limits listed in the UFP-QAPP. Otherwise, data will be flagged by the laboratory.

For field measurements such as pH, accuracy is often expressed in terms of bias (B) and is calculated as follows:

$$B = M - A$$

Where:

M = Measured value of Standard Reference Material (SRM)

A = Actual value of SRM

Sensitivity

Sensitivity is the ability of the analytical test method and/or instrumentation to differentiate between detector responses to varying concentrations of the target constituent. Methodology to establish sensitivity for a given analytical method or instrument includes examination of standardized blanks, instrument detection limit studies, and calibration of the QL. The findings of the usability of the data relative to sensitivity will be included in the report, including any limitations on the data set and/or individual analytical results.

The Precision, Accuracy, Representativeness, Completeness, Comparability and Sensitivity MPC are described in Worksheets 12, 15, and 28. The following steps will be performed:

Worksheet 37 — Data Usability Assessment (Continued)

(UFP-QAPP Manual Section 5.2.3 and Table 12)

(EPA 2106-G-05 Section 2.5.2, 2.5.3, and 2.5.4)

- Evaluate if the project required quantitation limits listed in Worksheet 15 were achieved for non-detected site contaminants. If no detectable results were reported and data are acceptable for the verification and validation steps, then the data are usable.
- If detectable concentrations are reported and the verification and validation steps are acceptable, the data are usable.
- If verification and validation are not acceptable, the data are qualified, estimated (J, UJ) for minor QC deviations that do not affect the data usability, or rejected for major QC deviations affecting data usability. The impact of rejected data will be evaluated and re-sampling may be necessary. Use of estimated data will be discussed in the project report.
- For statistical comparisons and mathematical manipulations, non-detect values will be represented by a concentration equal to one-half the sample-specific reporting limit. Duplicate results (original and duplicate) will not be averaged for the purpose of representing the range of concentrations. However, the average of the original and duplicate will be used to represent the concentration at that sample location.

Statistical tests will be conducted to identify potential outliers. Potential outliers will be removed if a review of the field and laboratory documentation indicates that the results are true outliers.

Method sensitivity is typically evaluated in terms of the method detection limit (MDL) and is defined as follows for many measurements:

$$MDL = t_{(n-1, 1-\alpha=0.99)}(s)$$

Where:

s = Standard deviation of the replicate analyses

$t_{(n-1, 1-\alpha=0.99)}$ = Student's t-value for a one-sided 99 percent confidence level and a standard deviation estimate with $n-1$ degrees of freedom

n = Number of measurements

α = Statistical significance level

Representativeness

Representativeness is the degree to which sample data accurately and precisely represent a characteristic of a population, parameter variations at a sampling point, or an environmental condition. It is a qualitative parameter that depends on proper design of the sampling program.

Data representativeness for this project is accomplished by implementing approved sampling procedures and analytical methods that are appropriate for the intended data uses, and which are established within the site-specific SAP, and/or QAPP.

Field personnel will be responsible for collecting and handling samples according to the procedures in this UFP-QAPP and the site-specific SAP, and/or QAPP so that samples are representative of field conditions. Errors in sample collection, packaging, preservation, or chain-of-custody procedures may result in samples being judged non-representative and may form a basis for rejecting the data.

Worksheet 37 — Data Usability Assessment (Continued)

(UFP-QAPP Manual Section 5.2.3 and Table 12)

(EPA 2106-G-05 Section 2.5.2, 2.5.3, and 2.5.4)

Comparability

Comparability is a qualitative parameter expressing the confidence with which one data set can be compared with another, whether it was generated by a single laboratory or during inter-laboratory studies. The use of standardized field and analytical procedures ensures comparability of analytical data. Sample collection and handling procedures will adhere to U.S. EPA-approved protocols. Laboratory procedures will follow standard analytical protocols, use standard units, use standardized report formats, follow the calculations as referenced in approved analytical methods, and use a standard statistical approach for QC measurements.

Completeness

Project-specific completeness goals account for all aspects of sample handling, from collection through data reporting. The level of completeness can be affected by loss or breakage of samples during transport, as well as external problems that prohibit collection of the sample. The following calculation is used for determining the percent complete:

$$\text{Completeness} = \frac{A}{B} \times 100$$

Where:

A = Actual number of measurements judged valid (the validity of a measurement result is determined by judging its suitability for its intended use)

B = Total number of measurements planned to achieve a specified level of confidence in decision making

The formula for sampling completeness is:

$$\text{Sampling Completeness} = \frac{\text{Number of locations sampled}}{\text{Number of planned sample locations}} \times 100$$

An example formula for analytical completeness is:

$$\text{Metals Analytical Completeness} = \frac{\text{Number of Usable Data Points}}{\text{Expected Number of Usable Data Points}} \times 100$$

The ability to meet or exceed completeness objectives is dependent on the nature of samples submitted for analysis.

Graphics

Graphic figures will be generated to depict sample locations, as needed. Also, if necessary, figures will be generated to represent contaminant concentrations at each sampling location. Each figure will contain a detailed legend.

Worksheet 37 — Data Usability Assessment (Continued)

(UFP-QAPP Manual Section 5.2.3 and Table 12)

(EPA 2106-G-05 Section 2.5.2, 2.5.3, and 2.5.4)

Reconciliation

PQOs will be examined to determine if the objective was met. This examination will include a combined overall assessment of the results of each analysis pertinent to an objective. Each analysis will first be evaluated separately in terms of the major impacts observed from the data verification and validation, DQIs, and MPC assessments. Based on the results of these assessments, the quality of the data will be determined. Based on the quality determined, the usability of the data for each analysis will be determined. Based on the combined usability of the data from all analyses for an objective, it will be determined if the PQO was met and whether project action limits were exceeded. As part of the reconciliation of each objective, conclusions will be drawn, and any limitations on the usability of any of the data will be described.

APPENDIX A
EPA REGION 8 QA DOCUMENT REVIEW CROSSWALK

EPA REGION 8 QA DOCUMENT REVIEW CROSSWALK

QAPP/FSP/SAP for: <i>(check appropriate box)</i>	Gold King Mine Blowout	Regulatory Authority and/or Funding Mechanism		40 CFR 31 for Grants
<input type="checkbox"/> GRANTEE	Region 8 START Contractor		<input checked="" type="checkbox"/>	48 CFR Part 46 for Contracts
<input checked="" type="checkbox"/> CONTRACTOR				Interagency Agreement
<input type="checkbox"/> EPA				EPA Administrative Order
<input type="checkbox"/> Other				EPA Program Funding
				EPA CIO 2105
Document Title <i>[Note: Title will be repeated in Header]</i>	SAP/QAPP for Gold King Mine Blowout			
QAPP/FSP/SAP Preparer	Mark Blanchard/Natalie Quiet			
Period of Performance (of QAPP/FSP/SAP)	1 year	Date Submitted for Review	8/9/2015	
EPA Project Officer	Joyce Ackerman	PO Phone #	303-312-6822	
EPA Project Manager	Craig Myers/Steve Way/Hays Griswold	PM Phone #		
QA Program Reviewer or Approving Official	Craig Myers	Date of Review		
Documents to Review:		Documents Submitted for QAPP Review:		
1. QAPP written by Grantee or EPA must also include for review:		1. QA Document(s) submitted for review:		
Work Plan(WP) / Statement of Work (SOW) / Program Plan (PP) / Research Proposal (RP)		QA Document	Document Date	Document Stand-alone
2. QAPP written by Contractor must also include for review:		QAPP	8/8/2015	No
Copy of signed QARF for Task Order		FSP	NA	Yes / No
a) Copy of Task Order SOW		SAP	8/8/2015	No
b) Made available hard or electronic copy of approved QMP		SOP(s)	NA	Yes / No
c) If QMP not approved, provide Contract SOW				Yes / No
d)				Yes / No
3. For a Field Sampling Plan (FSP) or Sampling & Analyses Plan (SAP), the Project QAPP		2. WP/SOW/TO/PP/RP Date <u>8/8/15</u>		
must <u>OR</u> so be provided.		WP/SOW/TO/PP/RP Date <u>8/8/15</u>		
The FSP or SAP must be clearly identified as a stand-alone QA document and must contain all QAPP required elements (Project Management, Data Generation/Acquisition, Assessment and Oversight, and Data Validation and Usability).		WP/SOW/TO/PP/RP Date <u>8/8/15</u>		
		WP/SOW/PP for grants? <u>Yes / No</u>		
		QARF signed by R8 QAM <u>Yes / No / NA</u>		
		Funding Mechanism <u>TA / contract / grant / NA</u>		
		Amount <u>_____</u>		
Summary of Comments <i>(highlight significant concerns/issues):</i>				
1. Comment #1				
2. Comment #2				
3. Comment #3				
4. Comment #4				

Element	Acceptable	Location	Comments
	Yes/No/NA		
A. Project Management			
A1. Title and Approval Sheet			
a. Contains project title	Yes	Title Page and Introduction Worksheet 1 & 2	
b. Date and revision number line (for when needed)	Yes	Revision Log	
c. Indicates organizations name	Yes	Title Page	
d. Date and signature line for organizations project manager	Yes	Worksheets 1 & 2 Worksheets 1,2 4,7 & 8	
e. Date and signature line for organizations QA manager	Yes	Worksheets 1& 2	
f. Other date and signatures lines, as needed	Yes	Worksheets 1 & 2 Worksheets 4,7 & 8	
A2. Table of Contents			
a. Lists QA Project Plan information sections	Yes	Table of Contents, SAP List of Appendices	
b. Document control information indicated	Yes	Title Page and Worksheet 1 & 2 Worksheet 1 & 2	
A3. Distribution List			
Includes all individuals who are to receive a copy of the QA Project Plan and identifies their organization	Yes	Introduction Worksheet 3 & 5	
A4. Project/Task Organization			
a. Identifies key individuals involved in all major aspects of the project, including contractors	Yes	Worksheet 3 & 5	
b. Discusses their responsibilities	Yes	Worksheet 4, 7 & 8	
c. Project QA Manager position indicates independence from unit generating data	Yes	Worksheet 3 & 5	
d. Identifies individual responsible for maintaining the official, approved QA Project Plan	Yes	Introduction Worksheet 4, 7 & 8	
e. Organizational chart shows lines of authority and reporting responsibilities	Yes	Worksheet 3 & 5	
A5. Problem Definition/Background			
a. States decision(s) to be made, actions to be taken, or outcomes expected from the information to be obtained	Yes	Worksheet 9, 11	
b. Clearly explains the reason (site background or historical context) for regulatory information, applicable criteria, action limits, etc. necessary to the project	Yes	Worksheet 10	
c. Identifies regulatory information, applicable criteria, action limits, etc. necessary to the project	Yes	Worksheets 10, 11, 15	
A6. Project/Task Description			
a. Summarizes work to be performed, for example, measurements to be made, data files to be obtained, etc., that support the projects goals	Yes	Worksheet 14 & 16, SAP Worksheet 17	

Element	Acceptable	Location	Comments
	Yes/No/NA		
b. Provides work schedule indicating critical project points, e.g., start and completion dates for activities such as sampling, analysis, data or file reviews, and assessments	Yes	Worksheet 14 & 16	
c. Details geographical locations to be studied, including maps where possible	Yes	Worksheets 10, 11	
d. Discusses resource and time constraints, if applicable	Yes		
A7. Quality Objectives and Criteria			
a. Identifies - performance/measurement criteria for all information to be collected and acceptance criteria for information obtained from previous studies, - including project action limits and laboratory detection limits and - range of anticipated concentrations of each parameter of interest	Yes	Worksheet 15 Worksheet 13 Worksheets 12.1 - 12.4	
b. Discusses precision	Yes	Worksheet 37	
c. Addresses bias	Yes		
d. Discusses representativeness	Yes		
e. Identifies the need for completeness	Yes		
f. Describes the need for comparability	Yes		
g. Discusses desired method sensitivity	Yes		
A8. Special Training/Certifications			
a. Identifies any project personnel specialized training or certifications	Yes	Worksheet 4, 7 & 8	
b. Discusses how this training will be provided	Yes		
c. Indicates personnel responsible for assuring training/certifications are satisfied	Yes		
d. identifies where this information is documented	Yes		
A9. Documentation and Records			
a. Identifies report format and summarizes all data report package information	Yes	Worksheets 14 & 16 Worksheet 29	
b. Lists all other project documents, records, and electronic files that will be produced	Yes	Worksheet 14 & 16	
c. Identifies where project information should be kept and for how long	Yes	Worksheet 29	
d. Discusses back up plans for records stored electronically	Yes	Worksheet 29	
e. States how individuals identified in A3 will receive the most current copy of the approved QA Project Plan, identifying the individual responsible for this	Yes	Introduction Worksheet 4 & 5	
B. Data Generation/Acquisition			

Element	Acceptable	Location	Comments
	Yes/No/NA		
B1. Sampling Process Design (Experimental Design)			
a. Describes and justifies design strategy, indicating size of the area, volume, or time period to be represented by a sample	Yes	Worksheet 11, 17	
b. Details the type and total number of sample types/matrix or test runs/trials expected and needed	Yes	Worksheets 11, 17, 18	
c. Indicates where samples should be taken, how sites will be identified/located	Yes		
d. Discusses what to do if sampling sites become inaccessible	Yes	Worksheet 17	
e. Identifies project activity schedules such as each sampling event, times samples should be sent to the laboratory, etc.	Yes		
f. Specifies what information is critical and what is for informational purposes only	Yes		
g. Identifies sources of variability and how this variability should be reconciled with project information	Yes		
B2. Sampling Methods			
a. Identifies all sampling SOPs by number, date, and regulatory citation, indicating sampling options or modifications to be taken	Yes	Worksheet 21	
b. Indicates how each sample/matrix type should be collected	Yes	Worksheet 17 Worksheet 19 & 30	
c. If in situ monitoring, indicates how instruments should be deployed and operated to avoid contamination and ensure maintenance of proper data	Yes	Worksheet 22	
d. If continuous monitoring, indicates averaging time and how instruments should store and maintain raw data, or data averages	Yes	Worksheet 11, Worksheet 22	Not Continuous
e. Indicates how samples are to be homogenized, composited, split, or filtered, if needed	Yes	Worksheet 17	
f. Indicates what sample containers and sample volumes should be used	Yes	Worksheet 17, SAP Table 1 Worksheet 19 & 30	
g. Identifies whether samples should be preserved and indicates methods that should be followed	Yes	Worksheet 17, SAP Table 1 Worksheet 19 & 30	
h. Indicates whether sampling equipment and samplers should be cleaned and/or decontaminated, identifying how this should be done and by-products disposed of	Yes	Worksheet 21	
i. Identifies any equipment and support facilities needed	Yes	Worksheet 22	

Element	Acceptable	Location	Comments
	Yes/No/NA		
j. Addresses actions to be taken when problems occur, identifying individual(s) responsible for corrective action and how this should be documented	Yes	Worksheet 17 Worksheet 31, 32 & 33	
B3. Sample Handling and Custody			
a. States maximum holding times allowed from sample collection to extraction and/or analysis for each sample type and, for in-situ or continuous monitoring, the maximum time before retrieval of information	Yes	Worksheet 19 & 30	
b. Identifies how samples or information should be physically handled, transported, and then received and held in the laboratory or office (including temperature upon receipt)	Yes	Worksheet 26 & 27	
c. Indicates how sample or information handling and custody information should be documented, such as in field notebooks and forms, identifying individual responsible	Yes	Worksheets 17, 26 & 27	
d. Discusses system for identifying samples, for example, numbering system, sample tags and labels, and attaches forms to the plan	Yes	Worksheet 11, 17, 18, 26 & 27	
e. Identifies chain-of-custody procedures and includes form to track custody	Yes		
B4. Analytical Methods			
a. Identifies all analytical SOPs (field, laboratory and/or office) that should be followed by number, date, and regulatory citation, indicating options or modifications to be taken, such as sub-sampling and extraction procedures	Yes	Worksheet 23	
b. Identifies equipment or instrumentation needed	Yes	Worksheets 23, 24	
c. Specifies any specific method performance criteria	Yes	Worksheet 22, 24	Worksheet 22 - Field Equipment Worksheet 24 - Analytical Instruments
d. Identifies procedures to follow when failures occur, identifying individual responsible for corrective action and appropriate documentation	Yes		
e. Identifies sample disposal procedures	Yes	Worksheet 26 & 27	
f. Specifies laboratory turnaround times needed	Yes	Worksheet 19 & 30	
g. Provides method validation information and SOPs for nonstandard methods	Yes	Worksheets 23, 25 & 28	
B5. Quality Control			
a. For each type of sampling, analysis, or measurement technique, identifies QC activities which should be used, for example, blanks, spikes, duplicates, etc., and at what frequency	Yes	Worksheet 20	

Element	Acceptable	Location	Comments
	Yes/No/NA		
b. Details what should be done when control limits are exceeded, and how effectiveness of control actions will be determined and documented	Yes	Worksheets 26 & 27, Worksheet 25 & 28	
c. Identifies procedures and formulas for calculating applicable QC statistics, for example, for precision, bias, outliers and missing data	Yes	Worksheet 37	
B6. Instrument/Equipment Testing, Inspection, and Maintenance			
a. Identifies field and laboratory equipment needing periodic maintenance, and the schedule for this	Yes	Worksheets 22, 24, and 25	
b. Identifies testing criteria	Yes		
c. Notes availability and location of spare parts	Yes		If equipment fails a replacement will be obtained.
d. Indicates procedures in place for inspecting equipment before usage	Yes	Worksheets 22, 24, and 25	
e. Identifies individual(s) responsible for testing, inspection and maintenance	Yes		
f. Indicates how deficiencies found should be resolved, re-inspections performed, and effectiveness of corrective action determined and documented	Yes	Worksheets 22, 24	
B7. Instrument/Equipment Calibration and Frequency			
a. Identifies equipment, tools, and instruments that should be calibrated and the frequency for this calibration	Yes	Worksheets 22 and 24	
b. Describes how calibrations should be performed and documented, indicating test criteria and standards or certified equipment	Yes	Worksheet 22, SAP Worksheet 26 & 27	
c. Identifies how deficiencies should be resolved and documented	Yes		
B8. Inspection/Acceptance for Supplies and Consumables			
a. Identifies critical supplies and consumables for field and laboratory, noting supply source, acceptance criteria, and procedures for tracking, storing and retrieving these materials	Yes	Worksheet 26 & 27 Worksheet 22,	
b. Identifies the individual(s) responsible for this	Yes		
B9. Use of Existing Data (Non-direct Measurements)			
a. Identifies data sources, for example, computer databases or literature files, or models that should be accessed and used	Yes	Worksheet 11 Worksheet 13	
b. Describes the intended use of this information and the rationale for their selection, i.e., its relevance to project	Yes	Worksheet 11 Worksheet 13	
c. Indicates the acceptance criteria for these data sources and/or models	Yes		
d. Identifies key resources/support facilities needed	Yes		
e. Describes how limits to validity and operating conditions should be determined, for example, internal checks of the program and Beta testing	Yes	Worksheet 11 Worksheet 13	

Element	Acceptable	Location	Comments
	Yes/No/NA		
B10. Data Management			
a. Describes data management scheme from field to final use and storage	Yes	Worksheets 26 & 27, Worksheets 29 & 35, Attachment B	
b. Discusses standard record-keeping and tracking practices, and the document control system or cites other written documentation such as SOPs	Yes	Worksheets 26 & 27 Worksheet 29	
c. Identifies data handling equipment/procedures that should be used to process, compile, analyze, and transmit data reliably and accurately	Yes	Worksheets 22, 23, and 29	
d. Identifies individual(s) responsible for this	Yes	Worksheet 29	
e. Describes the process for data archival and retrieval	Yes		
f. Describes procedures to demonstrate acceptability of hardware and software configurations	Yes	Worksheets 22 and 23	
g. Attaches checklists and forms that should be used	Yes	Worksheet 17 Attachment A	
C. Assessment and Oversight			
C1. Assessments and Response Actions			
a. Lists the number, frequency, and type of assessment activities that should be conducted, with the approximate dates	Yes	Worksheet 31, 32 & 33	
b. Identifies individual(s) responsible for conducting assessments, indicating their authority to issue stop work orders, and any other possible participants in the assessment process	Yes		
c. Describes how and to whom assessment information should be reported	Yes		
d. Identifies how corrective actions should be addressed and by whom, and how they should be verified and documented	Yes	Worksheet 31, 32 & 33	
C2. Reports to Management			
a. Identifies what project QA status reports are needed and how frequently	Yes	Worksheet 31, 32 & 33	
b. Identifies who should write these reports and who should receive this information	Yes	Worksheet 31, 32 & 33	
D. Data Validation and Usability			
D1. Data Review, Verification, and Validation			
Describes criteria that should be used for accepting, rejecting, or qualifying project data	Yes	Worksheet 36	
D2. Verification and Validation Methods			

Element	Acceptable	Location	Comments
	Yes/No/NA		
a. Describes process for data verification and validation, providing SOPs and indicating what data validation software should be used, if any	Yes	Worksheets 34, 35, 36	
b. Identifies who is responsible for verifying and validating different components of the project data/information, for example, chain-of-custody forms, receipt logs, calibration information, etc.	Yes	Worksheet 35	
c. Identifies issue resolution process, and method and individual responsible for conveying these results to data users	Yes	Worksheets 35 Worksheet 36	
d. Attaches checklists, forms, and calculations	Yes	Worksheet 34, 37	
D3. Reconciliation with User Requirements			
a. Describes procedures to evaluate the uncertainty of the validated data	Yes	Worksheets 12, 37	
b. Describes how limitations on data use should be reported to the data users	Yes	Worksheet 37	
D3. Reconciliation with User Requirements			
a. Describes procedures to evaluate the uncertainty of the validated data	Yes	Worksheets 11 Worksheets 12, 35, 36	
b. Describes how limitations on data use should be reported to the data users	Yes	Worksheet 12	

APPENDIX B
SITE SPECIFIC DATA MANAGEMENT PLAN

Gold King Mine ER Data Management Plan

 <p>This data management plan (DMP) is intended to provide guidance for data collection by field personnel and subsequent data management activities. The data collection and management practices presented in this plan are designed to ensure data integrity and consistency for all data collection personnel and from operational period to the next. This document is intended to be used in conjunction with the Region 8 Data Management Plan and only includes the details specific to the site.</p>	Site-Specific Data Management Plan			
	Project Name:	Gold King Mine ER	TDD Number/Site ID:	
	Author:	Megan Oller	Company:	Weston Solutions
	Date Initiated:	8/7/2015	Last Updated:	
Reviewed by: John Lucotch		Date: 8/7/2015		

Data Processing

The following table outlines the specific requirements for various data types being collected during the project.

Data Stream ¹	Site Specific Procedure (Y/N) ²	Required Information ³	Data Source ⁴	Site Specific Data Elements (Y/N)	QA Process ⁵	Data Repository ⁶	Reporting Task
Water Sampling Data	Y	<i>Location, sample number, sample matrix, water quality parameters</i>	Field logbook, water quality meter	Y	Reviewed by field personnel prior to import into scribe	Scribe.net	Results Report, Geospatial Viewer
Sediment Sampling Data	Y	<i>Location, sample number, sample matrix</i>	Field logbook, water quality meter	Y	Reviewed by field personnel prior to import into scribe	Scribe.net	Results Report, Geospatial Viewer
Photographic Data	N	<i>Location, date, time, description</i>	GPS Field Camera	N	PTL review during photo-log creation	EPAOSC.org	Site photo-log, Geospatial Viewer
Site Documents	N	<i>SAP, HASP, Customized data presentations</i>	START PTL	N	PTL and OSC Reviews	EPAOSC.org	NA
Analytical Data	N	<i>Chain of Custody, Laboratory Data from ESAT mobile lab</i>	Scribe, Laboratory EDD (in Tech Law LIMS format)	N	Review by field personnel prior to import to ensure all required fields are present and data maps accurately into scribe database (using ESAT data map)	Scribe.net	Results Report, Geospatial Viewer

Gold King Mine ER Data Management Plan

Data Stream¹	Site Specific Procedure (Y/N)²	Required Information³	Data Source⁴	Site Specific Data Elements (Y/N)	QA Process⁵	Data Repository⁶	Reporting Task
Project Costs	N	<i>Field Costs, Personnel Hours</i>	Weston time track reports, ODC reports, burn sheets	N	PTL Review	RCMS database	Weekly 1900 -1955 Forms, Email to OSC

1: Category of data generated for projects (i.e. monitoring data, water sampling data, locational data, photographs, analytical data, costs, etc). Create one line per category.

2: Y – indicates a site specific procedure is employed, N – indicates data management follows procedures outlined in the R8 DMP

3: Information necessary to provide a complete data record

4: Equipment or source that denerates data (i.e. TVA 1000, camera, iPad, Trimble GPS, laboratory EDD)

5: QA process related to data, do not include analytical data validation here

6: Location of data storage (i.e. epaosc.org, scribe.net, geospatial viewer)

Gold King Mine ER Data Management Plan

Attachment A Site Specific Data Elements and Valid Values

Ref. Project:

TDD:

Date:

This table provides detailed guidance for the collection of field data to be housed in the site scribe database. This table ensures site data is collected consistently across field teams and field events. This table exists in the Region 8 DMP with all of the default data elements and valid values – refer to DMP appendix A1 for a complete copy. Complete this table for data elements and valid values that are specific to your site. You may copy in lines that are especially important for your site data management or specify where you only want to use a limited list of the general valid values.

Data Element	Required	Description	Format	Scribe Table.Field	Valid Values*
Location	Yes	Identifier for a geographic point where samples or monitoring results are collected. Must be unique within a Site.	Text (30)	Location.Location	GKM##
LocationDescription	Yes	Brief description of a geographic point where samples or monitoring results are collected. Includes previously sampled nomenclature	Text (100)	Location. LocationDescription	Example: Toe of Gold King Mine Waste Dump, CC01C, CC19, etc.
SampleID	Yes	Identifier for a sample that is collected. Must be unique within a Site	Text (25)	Samples.Samp_No	LocationID_mmddy
Matrix	Yes	Matrix that is sampled.	Valid Values	Samples.Matrix	Water, Soil, Sediment
SampleCollection	Yes	The category of sample that is collected.	Valid Values	Samples.SampleCollection	Grab, Composite
SampleType	Yes	The category of Quality Control sample that is collected in the field (if appropriate).	Valid Values	Samples.SampleType	Field Sample, Blank, Duplicate
SampleDate	Yes	Date when a sample is collected. If a sampling duration is involved, enter the beginning date for this activity.	Date (MM/DD/YY)	Samples.SampleStartDate	
SampleTime	Conditional	Time when a sample is collected. If a sampling duration is involved, enter the beginning time for this activity. Required if Sample End Time is provided.	Time (24HH:MM:SS)	Samples.SampleStartTime	
Sample Media		Specification of sample matrix	Valid Values	Samples.SampleMedia	Potable Water, Surface Water, Groundwater, Surface Soil, Subsurface Soil

* Fill in additional site specific data elements/ valid values if identified in the field

NOTE: This table is meant to provide detailed guidance for the collection of field data to be housed in the site scribe database. This table ensures site data is collected consistently across field teams and field events. This table exists in the Region 8 DMP with all of the default data elements and valid values. You only have to fill out this table for data elements and valid values that are specific to your site. You may copy in lines that are especially important for your site data management or specify where you only want to use a limited list of the general valid values.

**Gold King Mine Release
Sampling and Analysis Plan/Quality Assurance Project Plan**

To: Craig Myers
From: Mark Blanchard, Natalie Quiet
CC: Joyce Ackerman, Richard Graham, Dan Wall
TDD#: 0001/1508-04
Date: 8/10/2015
DCN: W0267.1E.00532
Re: Addendum 1 to Gold King Mine Release SAP/QAPP – Residential Water Sampling

Comments: This is Addendum 1 to the Gold King Mine Release SAP/QAPP, dated 8/8/15. This Addendum provides the following:

1. Written protocol for collecting water samples from residences within the area affected by the Gold King Mine release.
2. A field form for collecting information on residents contacted.
3. A field form for collecting information regarding sample collection at residences.

STANDARD OPERATING PROCEDURE

RESIDENTIAL POTABLE WATER SUPPLY SAMPLING

(Based on EPA Region 4 EPA guidance document SESDPROC-305-R3: Potable Water Supply Sampling)

1. SCOPE AND APPLICATION

This Standard Operating Procedure (SOP) presents the procedures to be used by field personnel when collecting and handling residential potable water supply samples in the field. On the occasion that field personnel determine that any of the procedures described in this section are either inappropriate, inadequate or impractical and that another procedure must be used to obtain a groundwater sample, the variant procedure will be documented in the field log book, along with a description of the circumstances requiring its use. Mention of trade names or commercial products in this operating procedure does not constitute endorsement or recommendation for use.

2. EQUIPMENT

Personal protective equipment (see HASP)

Decontamination items

Rinse bottles

Trash bags

Paper towels

Field logbook

QAPP

Appropriate sampling device

Sharpies or other permanent marker

3. RELATED PROCEDURES

SOP ERT 2001	General Field Sampling Guidelines
SOP ERT 2006	Sampling Equipment Decontamination
SOP ERT 2049	Investigation-Derived Waste Management

4. GENERAL PRECAUTIONS

4.1 PROCEDURAL PRECAUTIONS

The following precautions should be considered when collecting potable water supply samples.

- Special care must be taken not to contaminate samples. This includes storing samples in a secure location to preclude conditions which could alter the properties of the sample. Samples shall be custody sealed during long-term storage or shipment.
- Always sample from the anticipated cleanest, i.e., least contaminated location, to the most contaminated location. This minimizes the opportunity for cross-contamination to occur during sampling.
- Collected samples must remain in the custody of the sampler or sample custodian until the samples are relinquished to another party.
- If samples are transported by the sampler, they will remain under his/her custody or be secured until they are relinquished.
- Shipped samples shall conform to all U.S. Department of Transportation (DOT) rules of shipment found in Title 49 of the Code of Federal Regulations (49 CFR Parts 171 to 179), and/or International Air Transportation Association (IATA) hazardous materials shipping requirements found in the current edition of IATA's Dangerous Goods Regulations.
- Documentation of field sampling is done in a bound logbook or field sheet.
- Chain-of-custody documents shall be filled out and remain with the samples until custody is relinquished.
- All shipping documents, such as air bills, bills of lading, etc., shall be retained by the project leader and stored in a secure place.

4.2 SPECIAL PRECAUTIONS FOR POTABLE WATER SUPPLY SAMPLING

- A clean pair of new, non-powdered, disposable gloves will be worn each time a different location is sampled and the gloves should be donned immediately prior to sampling. The gloves should not come in contact with the media being sampled and should be changed any time during sample collection when their cleanliness is compromised.
- Sample containers for samples suspected of containing high concentrations of contaminants shall be stored separately.

- Sample collection activities shall proceed progressively from the least suspected contaminated area to the most suspected contaminated area if sampling devices are to be reused. Samples of waste or highly contaminated media must not be placed in the same ice chest as environmental (i.e., containing low contaminant levels) or background samples.
- If possible, one member of the field sampling team should take all the notes and photographs, etc., while the other members collect the samples.
- Samplers must use new, verified and certified-clean disposable or non-disposable equipment cleaned according to procedures contained in the ERT SOP 2006 Sampling Equipment Decontamination for collection of samples for trace metals or organic compound analyses.

4.3 SAMPLE HANDLING AND PRESERVATION REQUIREMENTS

4.3.1 Sample Handling and Preservation Requirements

The following should be used when collecting samples from potable water supplies:

- Potable water supply samples will typically be collected from a tap or spigot located at or near the well head or pump house and before the water supply is introduced into any storage tanks or treatment units. Efforts should be made to reduce the flow from either the tap or spigot during sample collection to minimize sample agitation.
- During sample collection, make sure that the tap or spigot does not contact the sample container. Place the sample into appropriate containers. Samples collected for VOC analysis must not have any headspace. All other sample containers must be filled with an allowance for ullage.
- Samples requiring reduced temperature storage should be placed on ice immediately.

4.3.2 Sample Containers

Refer to the Quality Assurance Project Plan (QAPP) (WESTON, 2015) and the EPA-540-R-09-03 Contract Laboratory Program Guidance for Field Samplers for information on the required size and type of sample containers. Samples should be collected and containerized in the order of the volatilization sensitivity of the parameters.

4.3.3 Sample Preservation

All samples requiring preservation must be preserved as soon as practically possible, ideally immediately at the time of sample collection. If preserved VOC vials are used, these will be preserved with concentrated hydrochloric acid by field personnel prior to departure for the field investigation. Field personnel will also preserve with sodium hydroxide for water samples that

are being analyzed for cyanide. For all other chemical preservatives, field personnel will use the appropriate chemical preservative generally stored in an individual single-use vial as described in ERT SOP 2016 Sediment Sampling and EPA-540-R-09-03 Contract Laboratory Program Guidance for Field Samplers. The adequacy of sample preservation will be checked after the addition of the preservative for all samples except for the samples collected for VOC analysis. Additional preservative should be added to achieve adequate preservation.

4.4 QUALITY CONTROL

Equipment rinsate blanks should be collected if equipment is field cleaned and re-used on-site or if necessary to document that low-level contaminants were not introduced by any sampling equipment.

4.4.1 Documentation

Bound field logbooks should be used for the maintenance of field records. All aspects of sample collection and handling as well as visual observations shall be documented in the field logbooks.

All entries in field logbooks should be legibly recorded and contain accurate and inclusive documentation of project activities.

5. PROCEDURES

5.1 GENERAL

Obtain or confirm the following information:

- the name(s) of the resident(s) or water supply owner/operator
- the exact physical address
- the exact mailing address (if different from the physical address)
- the resident's/operator's home, work and mobile telephone numbers (when available)
- treatment system
- GPS coordinates of well location
- Photo documentation of well in relation to residence and spigot collecting sample from

The information is required so that the residents or water supply owner/operators can be informed of the results of the sampling program.

The following should be considered when choosing the location to collect a potable water sample:

- Taps selected for sample collection should be supplied with water from a service pipe connected directly to a water main in the segment of interest.
- Whenever possible, choose the tap closest to the water source, and prior to the water lines entering the residence, office, building, etc., and also prior to any holding or pressurization tanks.
- The sampling tap must be protected from exterior contamination associated with being too close to a sink bottom or to the ground. Contaminated water or soil from the faucet exterior may enter the bottle during the collection procedure since it is difficult to place a bottle under a low tap without grazing the neck interior against the outside faucet surface. If the tap is too close to the ground for direct collection into the appropriate container, it is acceptable to use a smaller container to transfer sample to a larger container. The smaller container should be made of glass or stainless steel, and should be decontaminated to the same standard as the larger container.
- Leaking taps that allow water to discharge from around the valve stem handle and down the outside of the faucet, or taps in which water tends to run up on the outside of the lip, are to be avoided as sampling locations.
- Disconnect any hoses, filters, or aerators attached to the tap before sampling. These devices can harbor a bacterial population if they are not routinely cleaned or replaced when worn or cracked.
- Taps where the water flow is not constant should be avoided because temporary fluctuation in line pressure may cause clumps of microbial growth that are lodged in a pipe section or faucet connection to break loose. A smooth flowing water stream at moderate pressure without splashing should be used. The sample should be collected without changing the water flow. It may be appropriate to reduce the flow for the volatile organic compounds aliquot to minimize sample agitation.

Occasionally, samples are collected to determine the contribution of system-related variables (e.g., transmission pipes, water coolers, water heaters, holding tanks, pressurization tanks, etc.) to the quality of potable water supplies. In these cases, it may be necessary to ensure that the water source has not been used for a specific time interval (e.g., over a weekend or a three- or four-day holiday period). Sample collection may consist of collecting a sample of the initial flush, collecting a sample after several minutes, and collecting another sample after the system being investigated has been completely purged.

5.2 PURGING

5.2.1 Potable Wells - Purging and Purge Adequacy

Wells with in-place plumbing are commonly found at residences. The objective of purging wells with in-place pumps is the same as with monitoring wells without in-place pumps, i.e., to ultimately collect a water sample representative of aquifer conditions.

Purging is the process of removing stagnant water immediately prior to sampling. In order to determine when an adequate purge has occurred, field investigators should monitor the pH, specific conductance and turbidity of the water removed during purging. For potable water supply sampling, it is recommended to purge the system for at least 15 minutes when possible.

An adequate purge is achieved when the pH and specific conductance of the potable water have stabilized and the turbidity has either stabilized or is below 10 Nephelometric Turbidity Units (NTUs). Although 10 NTUs is normally considered the minimum goal for most water sampling objectives, lower turbidity has been shown to be easily achievable in most situations and reasonable attempts should be made to achieve these lower levels. Stabilization occurs when, for at least three consecutive measurements, the pH remains constant within 0.1 Standard Unit (SU) and the specific conductance varies no more than approximately 10 percent. There are no set criteria establishing how many total sets of measurements are adequate to document stability of parameters.

If, after 15 minutes or significant temperature decrease indicating fresh groundwater has been reached, the in situ chemical parameters have not stabilized according to the above criteria, additional water can be removed. If the parameters have not stabilized after 15 minutes, it is at the discretion of the project leader whether or not to collect a sample or to continue purging.

A well with an intermittently run pump should, in all respects, be treated like a well without a pump. In these cases, parameters are measured and the well is sampled from the pump discharge after parameter conditions have been met. Generally, under these conditions, 15 to 30 minutes will be adequate.

5.3 INVESTIGATION DERIVED WASTE

Purging generates quantities of purge water or investigation derived waste (IDW), the disposition of which must be considered. See the ERT SOP 2049 for Investigation-Derived Waste Management for guidance on management or disposal of this waste.

6. POTABLE WATER SUPPLY SAMPLING METHODS – SAMPLING

6.1 GENERAL

Sampling is the process of obtaining, containerizing, and preserving (if required) a potable water supply water sample after the purging process is complete. It is recognized that there are situations, such as industrial or municipal supply wells or private residential wells, where a well may be equipped with a dedicated pump from which a sample would not normally be collected. Discretion should always be used in obtaining a sample.

6.1.1.1 Order of Sampling with Respect to Analytes

In many situations when sampling permanent or temporary monitoring wells, an adequate purge, with respect to turbidity, is often difficult to achieve. Removal and insertion of equipment after the purge and prior to actual sampling may negate the low turbidities achieved during purging and elevate turbidity back to unacceptable levels. For this reason, it is important that special efforts be used to minimize any disturbance of the water column after purging and to collect the aliquot for metals first.

A preferred collection order for some common parameters follows:

1. VOA.
2. Total organic carbon (TOC).
3. Extractable organics (base/neutral/acid (BNA) or semi-volatile organic compound (SVOC)).
4. Total metals.
5. Phenols.
6. Cyanide.
7. Total solids.

6.2 COLLECTING SAMPLES FROM RESIDENTIAL WELLS

Samples should be collected following purging from a valve or cold water tap as near to the well as possible, preferably prior to any storage/pressure tanks or physical/chemical treatment system that might be present. Remove any hose that may be present before sample collection and reduce the flow to a low level to minimize sample disturbance, particularly with respect to volatile organic constituents. Samples should be collected directly into the appropriate containers. It may be necessary to use a secondary container, such as a clean 8 oz. or similar size sample jar or a stainless steel scoop, to obtain and transfer samples from spigots with low ground clearance. All measurements for pH, specific conductance and turbidity should be recorded at the time of sample collection.

1. Ideally, the sample should be collected from a tap or spigot located at or near the well head or pump house and before the water supply is introduced into any storage tanks or treatment units. If the sample must be collected at a point in the water line beyond pressurization or holding tank, a sufficient volume of water should be purged to provide a complete exchange of fresh water into the tank and at the location where the sample is collected. If the sample is collected from a tap or spigot located just before a storage tank, spigots located inside the building or structure should be turned on to prevent any backflow from the storage tank to the sample tap or spigot. It is generally advisable to open several taps during the purge to ensure a rapid and complete exchange of water in the tanks.
2. Purge the system until temperature readings drop to approximately 10-15°C or for at least 15 minutes, when possible. During the purge period, obtain at least three sets of readings as follows: after purging for several minutes, measure the pH, specific conductivity and turbidity of the water. Continue to measure these parameters to assess for stabilization.
3. After three sets of readings have been obtained, samples may be collected. If stabilization has not occurred or after the 15-minute purge period, it is at the discretion of the project leader to collect the sample or continue purging and monitoring the parameters. This would depend on the condition of the system and the specific objectives of the investigation.

6.3 SPECIAL SAMPLE COLLECTION PROCEDURES

Special sample handling procedures should be instituted when trace contaminant samples are being collected. All sampling equipment which comes into contact with the water must be cleaned in accordance with the cleaning procedures described in the ERT SOP 2006 for Sampling Equipment Decontamination as applicable.

7. BIBLIOGRAPHY

International Air Transport Authority (IATA). Dangerous Goods Regulations, Most Recent Version.

Puls, Robert W., and Michael J. Barcelona. Filtration of Ground Water Samples for Metals Analysis. *Hazardous Waste and Hazardous Materials* 6(4): 385-393 (1989).

Puls, Robert W., Don A. Clark, and Bert Bledsoe. Metals in Ground Water: Sampling Artifacts and Reproducibility. *Hazardous Waste and Hazardous Materials* 9(2): 149-162 (1992).

SESD Potable Water Supply Sampling, SESDPROC-305-R3, Most Recent Version.

Title 49 Code of Federal Regulations, Pts. 171 to 179, Most Recent Version. US EPA. April 13, 1981. Final Regulation Package for Compliance with DOT.

Regulations in the Shipment of Environmental Laboratory Samples. Memo from David Weitzman, Work Group Chairman, Office of Occupational Health and Safety (PM-273).

US EPA. 2011. Investigation Derived Waste Management, SOP# 2049. ERT. June, 2011.

US EPA. 2011. Contract Laboratory Program Guidance for Field Samplers. Office of Superfund Remediation and Technology Innovation. OSWER Directive 9240.0-47. January 2011.

US EPA. 1995. Ground Water Sampling - A Workshop Summary. Proceedings from the Dallas, Texas November 30 - December 2, 1993 Workshop. Office of Research and Development Robert S. Kerr Environmental Research Laboratory. EPA/600/R-94/205.

US EPA. 1994. General Field Sampling Guidelines, SOP# 2001. Environmental Response Team (ERT). August 11, 1994.

US EPA. 1994. Sampling Equipment Decontamination, SOP# 2006. ERT. August 11, 1994.

US EPA. 1994. Sediment Sampling, SOP# 2016. ERT. November 17, 1994.

US EPA. 1992. Specifications and Guidance for Contaminant-Free Sample Containers. SOP # G-12. OSWER. EPA540/R-93/051. December 1992.

US EPA. 2001. Environmental Investigations Standard Operating Procedures and Quality Assurance Manual. Region 4 Science and Ecosystem Support Division (SESD), Athens, GA.

US EPA. Analytical Support Branch Laboratory Operations and Quality Assurance Manual. Region 4 SESD, Athens, GA, Most Recent Version.

WESTON (Weston Solutions, Inc.). 2015. *Sampling and Analysis Plan/Quality Assurance Project Plan (QAPP) For Gold King Mine Release, Silverton, San Juan County, Colorado*. Prepared for United States Environmental Protection Agency, Region 8.

Project:

Date	Initiated by	Contact Number (address or phone)	Notes

Field Sheet - Residential Water Sampling

Property Information					
Sampler Names/ID:				Date:	
Pad ID:		Property ID:		Parcel ID:	
Well Owner Name:			Well Owner Address:		
Well Owner Phone:		Alt Phone:	Property Address (Location of well if different from owner address):		
Occupant Name (if applicable):			Occupant Phone (if applicable):		
Property Type (Used as residence, for livestock, etc.):		Water Usage (Drinking water, recreation, livestock, etc.):		Water Disposal (City Sewer, Septic, Etc.):	
Weather:					
Well Information (Please Confirm if Possible)					
Well Permit Number:		Well Depth (ft):		Well Construction Date:	
Latitude (Dec. Degrees):		Longitude (Dec. Degrees):		Lat/Long Accuracy (ft):	
Ambient Wellhead Screening:	Time:	Time:	Well Ventilation:		
	ppm	%LEL	Sample Collection (pre/post treatment):		
Screened Interval (ft):			Water Level (ft):		
Treatment System (Water softener, filter, pressure tank, etc.):			Well Casing Diameter (inches):		
System Volume (Est.):		Purge Volume (gal):		Flow Rate (Est.):	
Sample Information					
Sample ID:		Sample	Time:	Sample COC:	
pH:	Temp °F:	DO %:	Running Water	Time:	Time:
Turbidity (NTU):	Conductivity (mS/cm):	Effervescence:		ppm	%LEL
Color:	Clarity:	Odors:	Head Space	Time:	Time:
Sample Description:				ppm	%LEL

Notes:

Project:

--	--	--	--

**Gold King Mine Release
Sampling and Analysis Plan/Quality Assurance Project Plan**

To: Craig Myers
From: Mark Blanchard, Natalie Quiet
CC: Joyce Ackerman, Richard Graham, Dan Wall
TDD#: 0001/1508-04
Date: 8/10/2015
DCN: W0267.1E.00533
Re: Addendum 2 to Gold King Mine Release SAP/QAPP – Sediment Sampling

Comments: This is Addendum 2 to the Gold King Mine Release SAP/QAPP, dated 8/8/15. This Addendum provides the following:

1. Written protocol for collecting sediment samples from within the area affected by the Gold King Mine release.
2. List of analytes and corresponding method detection limits by laboratory.
3. ERT Standard Operating Procedure for Sediment Sampling.

Purpose and Scope

START will collect sediment/sludge samples to characterize potential depositional impacts from the Gold King Mine release. Samples will be collected from within the area of potential impact from the release. Anticipated sampling locations include, but are not limited to:

- Boat ramps and/or river access points
- Irrigation diversions (inlets and outlets) to characterize background
- Streams to characterize background

Known sample locations will be current surface water sample locations and include:

Location	Latitude	Longitude	Description
GKM01	37.221542	-107.859455	Sample taken below River Road Bridge at the boat launch, near 50 River Road, Durango, CO.
GKM01	37.221542	-107.859455	River Road Bridge, past Home Depot, at the bottom of the boat ramp.
GKM03	37.790103	-107.667725	Location A72.
GKM04	37.294799	-107.870034	32nd Street Bridge, at the bottom of the boat ramp at Memorial Park.
GKM05	37.268704	-107.885857	Near the dog park off of US 160, under the pedestrian bridge near the concrete pathway.

Additional sample points will be determined in the field and will be located with a Global Positioning System (GPS) device to be used for mapping purposes and to document sample locations selected in the field. If sampling locations become inaccessible, alternate sampling locations which provide similarly adequate or sufficient data as the original will be identified and sampled based upon the best judgment of the inspector/sampler, if necessary.

Sampling and Field QC Procedures

Sampling will include collection of sediment/sludge samples from a depth of 0-2 cm in areas of deposition and will be biased for sampling of sludge material. Sample collection procedures will follow those in ERT SOP 2016. Samples will be analyzed for total metals using methods 6010B, 6020A and 7471A. Requirements for the sample container, volume, preservation, and QC samples are presented on Worksheet 19 & 30 (Sample Containers, Preservation and Hold Times) and Worksheet 20 (Field Quality Control Sample Summary) of the QAPP. The following table

lists sediment screening criteria that will be used to evaluate the analytical results of the sludge sample material and corresponding method detection limits by laboratory. Two potential laboratories have been identified at this time – Test America and ESAT.

Metal	Units	TEC ¹	PEC ¹	Test America MDLs			ESAT MDLs		
				6010B	6020A	7471A	6010C	6020A	7473
Arsenic	mg/kg	9.79	33	0.8	0.1	--	10	0.2	--
Cadmium	mg/kg	0.99	4.98	0.1	0.015	--	0.5	0.02	--
Chromium	mg/kg	43.4	111	0.21	0.11	--	0.5	0.2	--
Copper	mg/kg	31.6	149	0.17	0.13	--	0.2	0.1	--
Lead	mg/kg	35.8	128	0.34	0.05	--	2.5	0.02	--
Mercury	mg/kg	0.18	1.06	--	--	0.008	--	--	0.01
Nickel	mg/kg	22.7	48.6	0.38	0.26	--	1.0	0.1	--
Zinc	mg/kg	121	459	0.7	1	--	2.0	0.5	--

¹ Development and Evaluation of Consensus-Based Sediment Quality Guidelines for Freshwater Ecosystems, MacDonald (2000). TEC – threshold effect concentration. PEC – probable effect concentration.

START personnel will collect field duplicate and matrix spike/matrix spike duplicate (MS/MSD) samples and QA/QC samples as needed during the sampling activities. QA/QC samples will be collected as presented in Worksheet 20 of the QAPP.



SEDIMENT SAMPLING

SOP#: 2016
DATE: 11/17/94
REV. #: 0.0

1.0 SCOPE AND APPLICATION

This standard operating procedure (SOP) is applicable to the collection of representative sediment samples. Analysis of sediment may be biological, chemical, or physical in nature and may be used to determine the following:

- C toxicity;
- C biological availability and effects of contaminants;
- C benthic biota;
- C extent and magnitude of contamination;
- C contaminant migration pathways and source;
- C fate of contaminants;
- C grain size distribution.

The methodologies discussed in this SOP are applicable to the sampling of sediment in both flowing and standing water. They are generic in nature and may be modified in whole or part to meet the handling and analytical requirements of the contaminants of concern, as well as the constraints presented by site conditions and equipment limitations. However, if modifications occur, they should be documented in a site or personal logbook and discussed in reports summarizing field activities and analytical results.

For the purposes of this procedure, sediments are those mineral and organic materials situated beneath an aqueous layer. The aqueous layer may be either static, as in lakes, ponds, and impoundments; or flowing, as in rivers and streams.

Mention of trade names or commercial products does not constitute U.S. EPA endorsement or recommendation for use.

2.0 METHOD SUMMARY

Sediment samples may be collected using a variety of methods and equipment, depending on the depth of the aqueous layer, the portion of the sediment profile

required (surface vs. subsurface), the type of sample required (disturbed vs. undisturbed), contaminants present, and sediment type.

Sediment is collected from beneath an aqueous layer either directly, using a hand held device such as a shovel, trowel, or auger; or indirectly, using a remotely activated device such as an Ekman or Ponar dredge. Following collection, sediment is transferred from the sampling device to a sample container of appropriate size and construction for the analyses requested. If composite sampling techniques are employed, multiple grabs are placed into a container constructed of inert material, homogenized, and transferred to sample containers appropriate for the analyses requested. The homogenization procedure should not be used if sample analysis includes volatile organics; in this case, sediment, or multiple grabs of sediment, should be transferred directly from the sample collection device or homogenization container to the sample container.

3.0 SAMPLE PRESERVATION, CONTAINERS, HANDLING AND STORAGE

1. Chemical preservation of solids is generally not recommended. Cooling to 4°C is usually the best approach, supplemented by the appropriate holding time for the analyses requested.
2. Wide mouth glass containers with Teflon lined caps are utilized for sediment samples. The sample volume is a function of the analytical requirements and will be specified in the Work Plan.
3. If analysis of sediment from a discrete depth or location is desired, sediment is transferred directly from the sampling device to a labeled sample container(s) of appropriate size and construction for the analyses

requested. Transfer is accomplished with a stainless steel or plastic lab spoon or equivalent.

4. If composite sampling techniques or multiple grabs are employed, equal portions of sediment from each location are deposited into a stainless steel, plastic, or other appropriate composition (e.g., Teflon) containers. The sediment is homogenized thoroughly to obtain a composite representative of the area sampled. The composite sediment sample is transferred to a labeled container(s) of appropriate size and construction for the analyses requested. Transfer of sediment is accomplished with a stainless steel or plastic lab spoon or equivalent. Samples for volatile organic analysis must be transferred directly from the sample collection device or pooled from multiple areas in the homogenization container prior to mixing. This is done to minimize loss of contaminant due to volatilization during homogenization.
5. All sampling devices should be decontaminated, then wrapped in aluminum foil. The sampling device should remain in this wrapping until it is needed. Each sampling device should be used for only one sample. Disposable sampling devices for sediment are generally impractical due to cost and the large number of sediment samples which may be required. Sampling devices should be cleaned in the field using the decontamination procedure described in the Sampling Equipment Decontamination SOP.

4.0 INTERFERENCES AND POTENTIAL PROBLEMS

Substrate particle size and organic matter content are a direct consequence of the flow characteristics of a waterbody. Contaminants are more likely to be concentrated in sediments typified by fine particle size and a high organic matter content. This type of sediment is most likely to be collected from depositional zones. In contrast, coarse sediments with low organic matter content do not typically concentrate pollutants and are generally found in erosional zones. The selection of a sampling location

can, therefore, greatly influence the analytical results and should be justified and specified in the Work Plan.

5.0 EQUIPMENT/APPARATUS

Equipment needed for collection of sediment samples may include:

- C Maps/plot plan
- C Safety equipment
- C Compass
- C Tape measure
- C Survey stakes, flags, or buoys and anchors
- C Camera and film
- C Stainless steel, plastic, or other appropriate composition bucket
- C 4-oz., 8-oz., and one-quart wide mouth jars w/Teflon lined lids
- C Ziploc plastic bags
- C Logbook
- C Sample jar labels
- C Chain of Custody records, field data sheets
- C Cooler(s)
- C Ice
- C Decontamination supplies/equipment
- C Spade or shovel
- C Spatula
- C Scoop
- C Trowel
- C Bucket auger
- C Tube auger
- C Extension rods
- C "T" handle
- C Sediment coring device (tube, drive head, eggshell check valve, nosecone, acetate tube, extension rods, "T" handle)
- C Ponar dredge
- C Ekman dredge
- C Nylon rope or steel cable
- C Messenger device

6.0 REAGENTS

Reagents are not used for preservation of sediment samples. Decontamination solutions are specified in the Sampling Equipment Decontamination SOP.

7.0 PROCEDURES

7.1 Preparation

1. Determine the objective(s) and extent of the sampling effort. The sampling methods to be employed, and the types and amounts of equipment and supplies required will be a function of site characteristics and objectives of the study.
2. Obtain the necessary sampling and monitoring equipment.
3. Prepare schedules, and coordinate with staff, client, and regulatory agencies, if appropriate.
4. Decontaminate or preclean equipment, and ensure that it is in working order.
5. Perform a general site survey prior to site entry in accordance with the site specific Health and Safety Plan.
6. Use stakes, flagging, or buoys to identify and mark all sampling locations. Specific site factors including flow regime, basin morphometry, sediment characteristics, depth of overlying aqueous layer, contaminant source, and extent and nature of contamination should be considered when selecting sample locations. If required, the proposed locations may be adjusted based on site access, property boundaries, and surface obstructions.

7.2 Sample Collection

Selection of a sampling device is most often contingent upon: (1) the depth of water at the sampling location, and (2) the physical characteristics of the sediment to be sampled. The following procedures may be utilized:

7.2.1 Sampling Surface Sediment with a Trowel or Scoop from Beneath a Shallow Aqueous Layer

For the purpose of this method, surface sediment is considered to range from 0 to six inches in depth and

a shallow aqueous layer is considered to range from 0 to 12 inches in depth. Collection of surface sediment from beneath a shallow aqueous layer can be accomplished with tools such as spades, shovels, trowels, and scoops. Although this method can be used to collect both unconsolidated/consolidated sediment, it is limited somewhat by the depth and movement of the aqueous layer. Deep and rapidly flowing water render this method less accurate than others discussed below. However, representative samples can be collected with this procedure in shallow sluggish water provided care is demonstrated by the sample team member. A stainless steel or plastic sampling implement will suffice in most applications. Care should be exercised to avoid the use of devices plated with chrome or other materials; plating is particularly common with garden trowels.

The following procedure will be used to collect sediment with a scoop, shovel, or trowel:

1. Using a decontaminated sampling implement, remove the desired thickness and volume of sediment from the sampling area.
2. Transfer the sample into an appropriate sample or homogenization container. Ensure that non-dedicated containers have been adequately decontaminated.
3. Surface water should be decanted from the sample or homogenization container prior to sealing or transfer; care should be taken to retain the fine sediment fraction during this procedure.

7.2.2 Sampling Surface Sediment with a Bucket Auger or Tube Auger from Beneath a Shallow Aqueous Layer

For the purpose of this method, surface sediment is considered to range from 0 to six inches in depth and a shallow aqueous layer is considered to range from 0 to 24 inches in depth. Collection of surface sediment from beneath a shallow aqueous layer can be accomplished with a system consisting of bucket auger or tube auger, a series of extensions, and a "T" handle (Figure 1, Appendix A). The use of additional extensions in conjunction with a bucket auger can increase the depth of water from which sediment can be collected from 24 inches to 10 feet or more. However, sample handling and manipulation increases

in difficulty with increasing depth of water. The bucket auger or tube auger is driven into the sediment and used to extract a core. The various depths represented by the core are homogenized or a subsample of the core is taken from the appropriate depth.

The following procedure will be used to collect sediment samples with a bucket auger or tube auger:

1. An acetate core may be inserted into the bucket auger or tube auger prior to sampling if characteristics of the sediments or waterbody warrant. By using this technique, an intact core can be extracted.
2. Attach the auger head to the required length of extensions, then attach the "T" handle to the upper extension.
3. Clear the area to be sampled of any surface debris.
4. Insert the bucket auger or tube auger into the sediment at a 0° to 20° angle from vertical. This orientation minimizes spillage of the sample from the sampler upon extraction from the sediment and water.
5. Rotate the auger to cut a core of sediment.
6. Slowly withdraw the auger; if using a tube auger, make sure that the slot is facing upward.
7. Transfer the sample or a specified aliquot of sample into an appropriate sample or homogenization container. Ensure that non-dedicated containers have been adequately decontaminated.

7.2.3 Sampling Deep Sediment with a Bucket Auger or Tube Auger from Beneath a Shallow Aqueous Layer

For the purpose of this method, deep sediment is considered to range from six to greater than 18 inches in depth and a shallow aqueous layer is considered to range from 0 to 24 inches. Collection of deep sediment from beneath a shallow aqueous layer can be accomplished with a system consisting of a bucket auger, a tube auger, a series of extensions and a

"T" handle. The use of additional extensions can increase the depth of water from which sediment can be collected from 24 inches to five feet or more. However, water clarity must be high enough to permit the sampler to directly observe the sampling operation. In addition, sample handling and manipulation increases in difficulty with increasing depth of water. The bucket auger is used to bore a hole to the upper range of the desired sampling depth and then withdrawn. The tube auger is then lowered down the borehole, and driven into the sediment to the lower range of the desired sampling depth. The tube is then withdrawn and the sample recovered from the tube. This method can be used to collect firmly consolidated sediments, but is somewhat limited by the depth of the aqueous layer, and the integrity of the initial borehole.

The following procedure will be used to collect deep sediment samples with a bucket auger and a tube auger:

1. Attach the bucket auger bit to the required lengths of extensions, then attach the "T" handle to the upper extension.
2. Clear the area to be sampled of any surface debris.
3. Begin augering, periodically removing any accumulated sediment (i.e., cuttings) from the auger bucket. Cuttings should be disposed of far enough from the sampling area to minimize cross contamination of various depths.
4. After reaching the upper range of the desired depth, slowly and carefully remove bucket auger from the boring.
5. Attach the tube auger bit to the required lengths of extensions, then attach the "T" handle to the upper extension.
6. Carefully lower tube auger down borehole using care to avoid making contact with the borehole sides and, thus, cross contaminating the sample. Gradually force tube auger into sediment to the lower range of the desired sampling depth. Hammering of the tube auger to facilitate coring should be avoided as the vibrations may cause the boring walls

to collapse.

7. Remove tube auger from the borehole, again taking care to avoid making contact with the borehole sides and, thus, cross contaminating the sample.
8. Discard the top of core (approximately 1 inch); as this represents material collected by the tube auger before penetration to the layer of concern.
9. Transfer sample into an appropriate sample or homogenization container. Ensure that non-dedicated containers have been adequately decontaminated.

7.2.4 Sampling Surface Sediment with an Ekman or Ponar Dredge from Beneath a Shallow or Deep Aqueous Layer

For the purpose of this method, surface sediment is considered to range from 0 to six inches in depth. Collection of surface sediment can be accomplished with a system consisting of a remotely activated device (dredge) and a deployment system. This technique consists of lowering a sampling device (dredge) to the surface of the sediment by use of a rope, cable, or extended handle. The mechanism is activated, and the device entraps sediment in spring loaded or lever operated jaws.

An Ekman dredge is a lightweight sediment sampling device with spring activated jaws. It is used to collect moderately consolidated, fine textured sediment. The following procedure will be used for collecting sediment with an Ekman dredge (Figure 2, Appendix A):

1. Attach a sturdy nylon rope or stainless steel cable through the hole on the top of the bracket, or secure the extension handle to the bracket with machine bolts.
2. Attach springs to both sides of the jaws. Fix the jaws so that they are in open position by placing trip cables over the release studs. Ensure that the hinged doors on the dredge top are free to open.
3. Lower the sampler to a point 4 to 6 inches

above the sediment surface.

4. Drop the sampler to the sediment.
5. Trigger the jaw release mechanism by lowering a messenger down the line, or by depressing the button on the upper end of the extension handle.
6. Raise the sampler and slowly decant any free liquid through the top of the sampler. Care should be taken to retain the fine sediment fraction during this procedure.
7. Open the dredge jaws and transfer the sample into a stainless steel, plastic or other appropriate composition (e.g., Teflon) container. Ensure that non-dedicated containers have been adequately decontaminated. If necessary, continue to collect additional sediment grabs until sufficient material has been secured to fulfill analytical requirements. Thoroughly homogenize and then transfer sediment to sample containers appropriate for the analyses requested. Samples for volatile organic analysis must be collected directly from the bucket before homogenization to minimize volatilization of contaminants.

A Ponar dredge is a heavyweight sediment sampling device with weighted jaws that are lever or spring activated. It is used to collect consolidated fine to coarse textured sediment. The following procedure will be used for collecting sediment with a Ponar dredge (Figure 3, Appendix A):

1. Attach a sturdy nylon rope or steel cable to the ring provided on top of the dredge.
2. Arrange the Ponar dredge with the jaws in the open position, setting the trip bar so the sampler remains open when lifted from the top. If the dredge is so equipped, place the spring loaded pin into the aligned holes in the trip bar.
3. Slowly lower the sampler to a point approximately two inches above the sediment.
4. Drop the sampler to the sediment. Slack on

the line will release the trip bar or spring loaded pin; pull up sharply on the line closing the dredge.

5. Raise the dredge to the surface and slowly decant any free liquid through the screens on top of the dredge. Care should be taken to retain the fine sediment fraction during this operation.
6. Open the dredge and transfer the sediment to a stainless steel, plastic or other appropriate composition (e.g., Teflon) container. Ensure that non-dedicated containers have been adequately decontaminated. If necessary, continue to collect additional sediment until sufficient material has been secured to fulfill analytical requirements. Thoroughly homogenized and then transfer sediment to sample containers appropriate for the analyses requested. Samples for volatile organic analysis must be collected directly from the bucket before homogenization to minimize volatilization of contaminants.

7.2.5 Sampling Subsurface Sediment with a Coring Device from Beneath a Shallow Aqueous Layer

For purposes of this method, subsurface sediment is considered to range from 6 to 24 inches in depth and a shallow aqueous layer is considered to range from 0 to 24 inches in depth. Collection of subsurface sediment from beneath a shallow aqueous layer can be accomplished with a system consisting of a tube sampler, acetate tube, eggshell check valve, nosecone, extensions, and "T" handle, or drivehead. The use of additional extensions can increase the depth of water from which sediment can be collected from 24 inches to 10 feet or more. This sampler may be used with either a drive hammer for firm sediment, or a "T" handle for soft sediment. However, sample handling and manipulation increases in difficulty with increasing depth of water.

The following procedure describes the use of a sample coring device (Figure 4, Appendix A) used to collect subsurface sediments.

1. Assemble the coring device by inserting the acetate core into the sampling tube.

2. Insert the "egg shell" check valve into the lower end of the sampling tube with the convex surface positioned inside the acetate core.
3. Screw the nosecone onto the lower end of the sampling tube, securing the acetate tube and eggshell check valve.
4. Screw the handle onto the upper end of the sampling tube and add extension rods as needed.
5. Place the sampler in a perpendicular position on the sediment to be sampled.
6. If the "T" handle is used, place downward pressure on the device until the desired depth is reached. After the desired depth is reached, rotate the sampler to shear off the core at the bottom. Slowly withdraw the sampler from the sediment and proceed to Step 15.
7. If the drive hammer is selected, insert the tapered handle (drive head) of the drive hammer through the drive head.
8. Drive the sampler into the sediment to the desired depth.
9. Record the length of the tube that penetrated the sample material, and the number of blows required to obtain this depth.
10. Remove the drive hammer and fit the keyhole-like opening on the flat side of the hammer onto the drive head. In this position, the hammer serves as a handle for the sampler.
11. Rotate the sampler to shear off the core at the bottom.
12. Lower the sampler handle (hammer) until it just clears the two ear-like protrusions on the drive head, and rotate about 90°.
13. Slowly withdraw the sampler from the sediment. If the drivehead was used, pull the hammer upwards and dislodge the sampler from the sediment.

14. Carefully remove the coring device from the water.
15. Unscrew the nosecone and remove the eggshell check valve.
16. Slide the acetate core out of the sampler tube. Decant surface water, using care to retain the fine sediment fraction. If head space is present in the upper end, a hacksaw may be used to shear the acetate tube off at the sediment surface. The acetate core may then be capped at both ends. Indicate on the acetate tube the appropriate orientation of the sediment core using a waterproof marker. The sample may be used in this fashion, or the contents transferred to a sample or homogenization container.
17. Open the acetate tube and transfer the sediment to a stainless steel, plastic or other appropriate composition (e.g., Teflon) container. Ensure that non-dedicated containers have been adequately decontaminated. If necessary, continue to collect additional sediment until sufficient material has been secured to fulfill analytical requirements. Thoroughly homogenize and then transfer sediment to sample containers appropriate for the analyses requested. Samples for volatile organic analysis must be collected directly from the bucket before homogenization to minimize volatilization of contaminants.

8.0 CALCULATIONS

This section is not applicable to this SOP.

9.0 QUALITY ASSURANCE/ QUALITY CONTROL

There are no specific quality assurance (QA) activities which apply to the implementation of these procedures. However, the following QA procedures apply:

1. All data must be documented on field data sheets or within site logbooks.

2. All instrumentation must be operated in accordance with operating instructions as supplied by the manufacturer, unless otherwise specified in the work plan. Equipment checkout and calibration activities must occur prior to sampling/operation, and they must be documented.

10.0 DATA VALIDATION

This section is not applicable to this SOP.

11.0 HEALTH AND SAFETY

When working with potentially hazardous materials, follow U.S. EPA/OSHA and Corporate health and safety procedures.

More specifically, when sampling sediment from waterbodies, physical hazards must be identified and adequate precautions must be taken to ensure the safety of the sampling team. The team member collecting the sample should not get too close to the edge of the waterbody, where bank failure may cause loss of balance. To prevent this, the person performing the sampling should be on a lifeline, and be wearing adequate protective equipment. If sampling from a vessel is determined to be necessary, appropriate protective measures must be implemented.

12.0 REFERENCES

Mason, B.J., Preparation of Soil Sampling Protocol: Technique and Strategies. 1983 EPA-600/4-83-020.

Barth, D.S. and B.J. Mason, Soil Sampling Quality Assurance User's Guide. 1984 EPA-600/4-84-043.

U.S. EPA. Characterization of Hazardous Waste Sites - A Methods Manual: Volume II. Available Sampling Methods, Second Edition. 1984 EPA-600/4-84-076.

de Vera, E.R., B.P. Simmons, R.D. Stephen, and D.L. Storm. Samplers and Sampling Procedures for Hazardous Waste Streams. 1980 EPA-600/2-80-018.

APPENDIX A

Figures

FIGURE 1. Sampling Auger

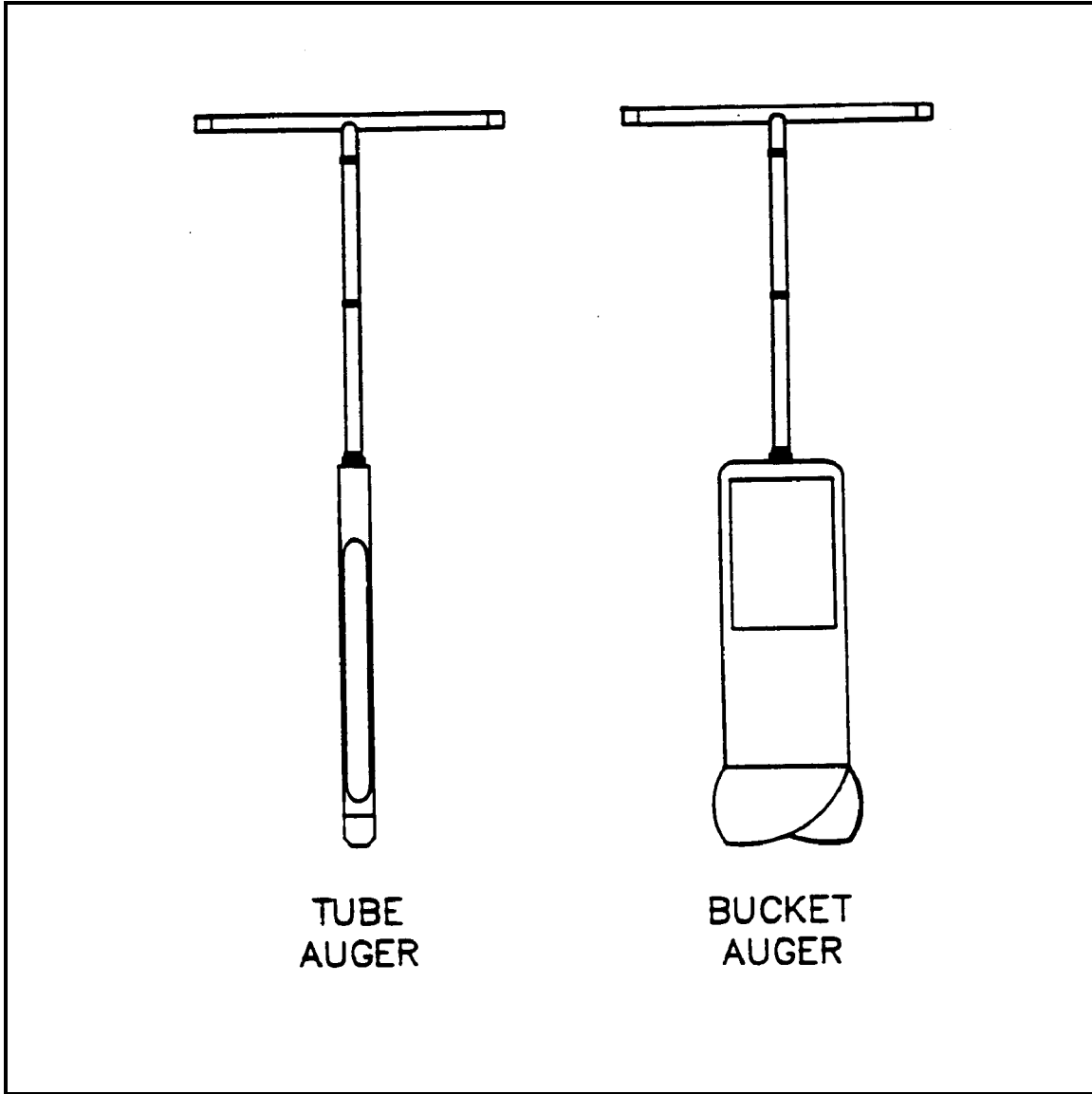

APPENDIX A (Cont'd)

Figures

FIGURE 2. Ekman Dredge

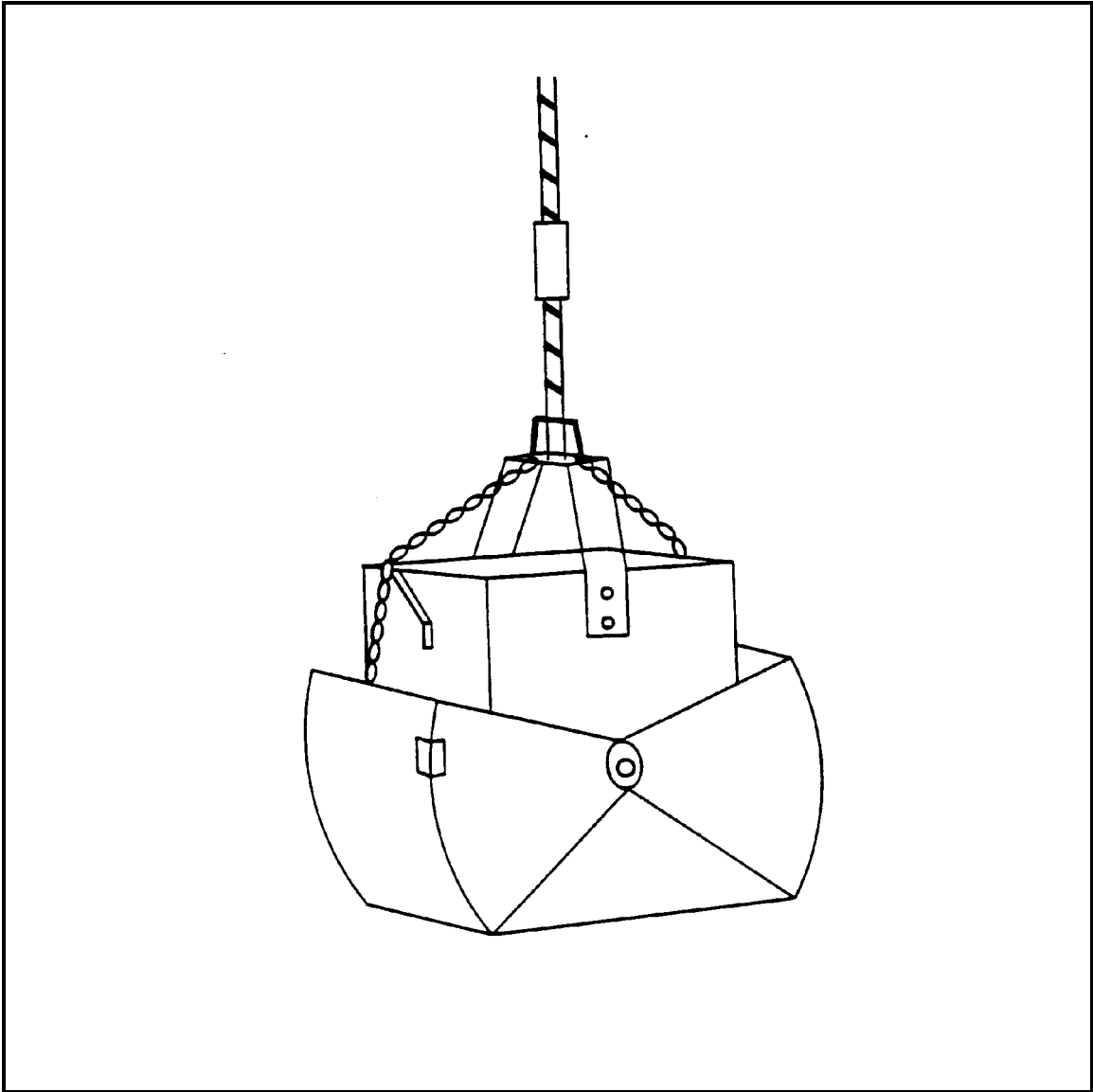

APPENDIX A (Cont'd)

Figures

FIGURE 3. Ponar Dredge

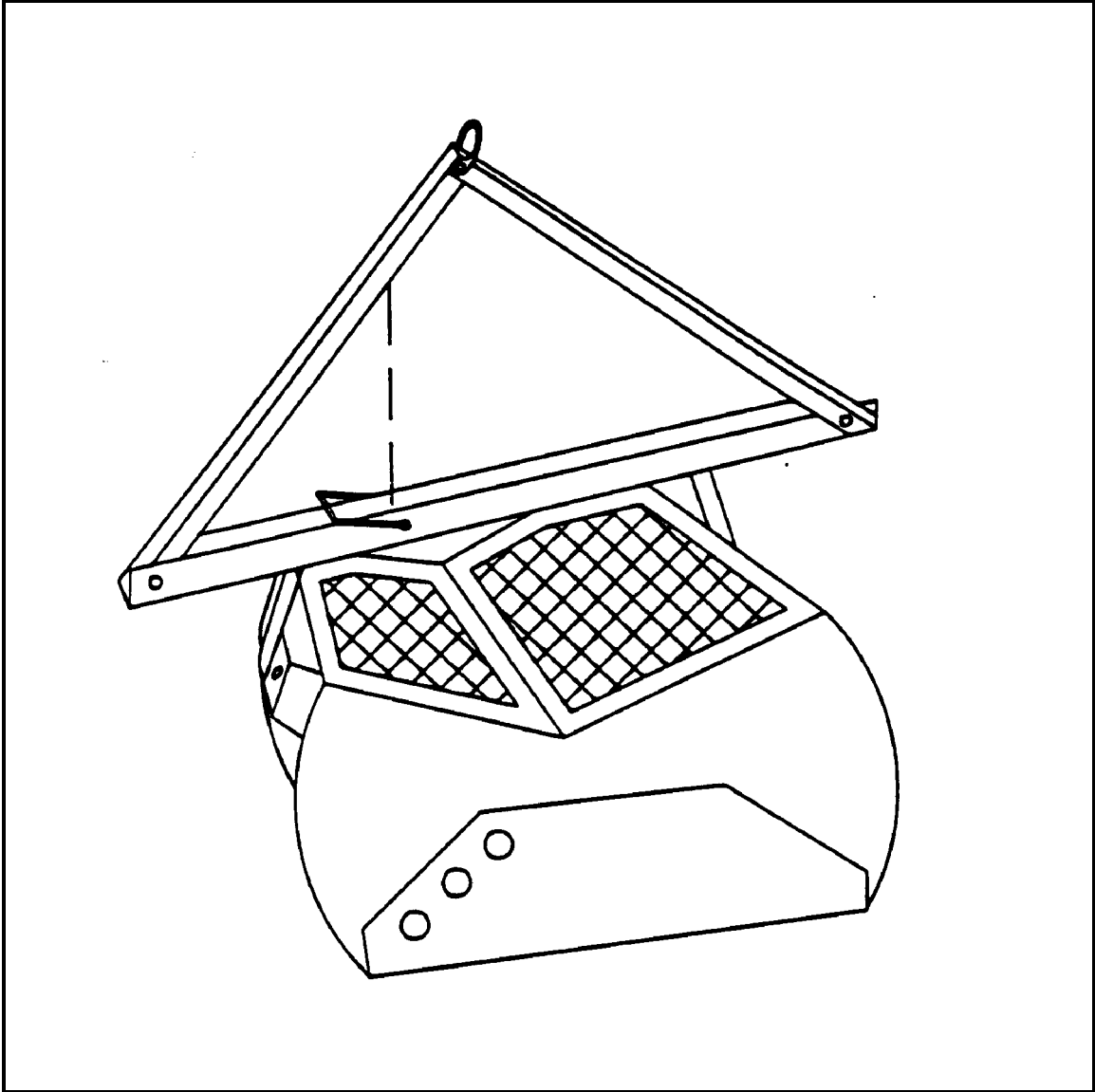

APPENDIX A (Cont'd)

Figures

FIGURE 4. Sample Coring Device

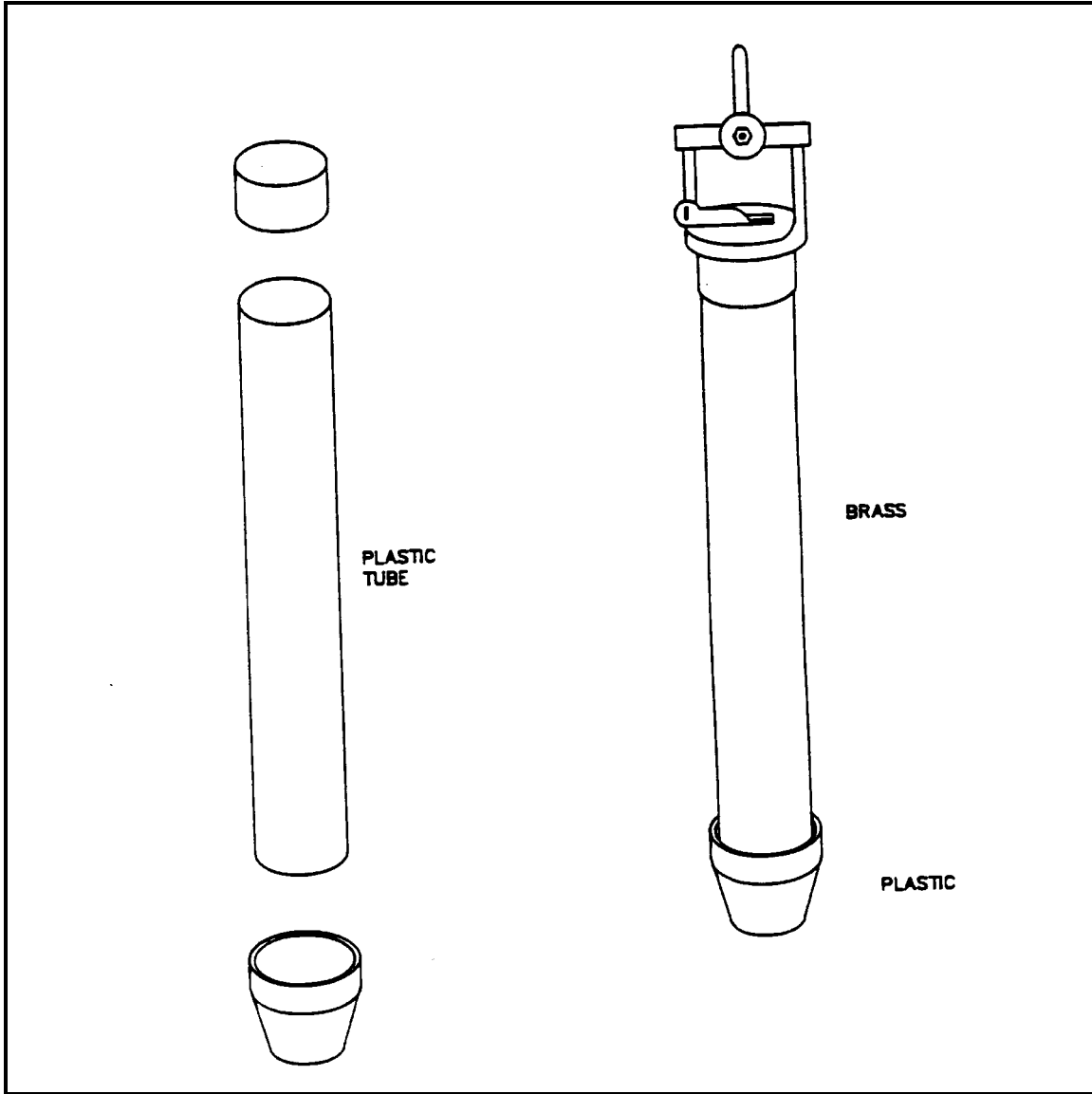

**Gold King Mine Release
Sampling and Analysis Plan/Quality Assurance Project Plan**

To: Craig Myers
From: Mark Blanchard
CC: Joyce Ackerman, Richard Graham, Joyel Dhieux, Dan Wall
TDD#: 0001/1508-04
Date: 8/11/2015
DCN: W0267.1E.00534
Re: Addendum 3 to Gold King Mine Release SAP/QAPP – Surface Soil Sampling

Comments: This is Addendum 3 to the Gold King Mine Release SAP/QAPP, dated 8/8/15. This Addendum provides the following:

1. Written protocol for collecting surface soil samples from within the area affected by the Gold King Mine release.
2. List of analytes and corresponding detection limits by laboratory.
3. ERT Standard Operating Procedure for Soil Sampling.

Purpose and Scope

START will collect surface soil samples to characterize depositional impacts from the Gold King Mine release. Samples will be collected from within the area of potential impact from the release. Anticipated sampling locations include, but are not limited to:

- Irrigation diversions
- Agricultural fields
- Stream and river banks

Sample points will be determined in the field and will be located with a Global Positioning System (GPS) device to be used for mapping purposes and to document sample locations selected in the field. If sampling locations become inaccessible, alternate sampling locations which provide similarly adequate or sufficient data as the original will be identified and sampled based upon the best judgment of the inspector/sampler, if necessary.

Sampling and Field QC Procedures

Sampling will include collection of surface soil samples from a depth of 0-2 cm and will be biased for sampling in areas of potential contamination. Sample collection procedures will follow those in ERT SOP 2012. Samples will be analyzed for total metals using methods 6010B, 6020A, and 7471A. Requirements for the sample container, volume, preservation, and QC samples are presented on Worksheet 19 & 30 (Sample Containers, Preservation and Hold Times) and Worksheet 20 (Field Quality Control Sample Summary) of the QAPP. The following table lists surface soil screening criteria that may be used to evaluate the analytical results of the surface soil samples and corresponding method detection limits by laboratory.

Metal	CAS	Units	EPA Soil RSLs		EPA Eco-SSL				Test America			ESAT		
			Residential	Industrial	Avian	Invertebrate	Mammalian	Plants	6010B	6020A	7471A	6010C	6020A	7471A
Aluminum	7429-90-5	mg/Kg	77000	1100000	NE	NE	NE	NE	3.10	2.10	--	2.00	0.5	--
Antimony	7440-36-0	mg/Kg	31	470	NE	78	0.27	NE	0.820	0.100	--	5.00	0.05	--
Arsenic	7440-38-2	mg/Kg	0.68	3	43	NE	46	18	0.800	0.100	--	6.00	0.05	--
Barium	7440-39-3	mg/Kg	15000	220000	NE	330	2000	NE	0.160	0.0600	--	0.20	0.5	--
Beryllium	7440-41-7	mg/Kg	160	2300	NE	40	21	NE	0.0100	0.0150	--	0.20	0.01	--
Cadmium	7440-43-9	mg/Kg	71	980	0.77	140	0.36	32	0.100	0.0150	--	0.20	0.01	--
Calcium	7440-70-2	mg/Kg	NE	NE	NE	NE	NE	NE	5.20	6.3	--	10.00	--	
Chromium	7440-47-3	mg/Kg	NE	NE	NE	NE	NE	NE	0.210	0.0100	--	0.20	0.01	--
Cobalt	7440-48-4	mg/Kg	23	350	120	NE	230	13	0.100	0.110	--	0.20	0.1	--
Copper	7440-50-8	mg/Kg	3100	47000	120	NE	230	13	0.170	0.130	--	0.20	0.05	--
Iron	7439-89-6	mg/Kg	55000	820000	NE	NE	NE	NE	5.30	3.50	--	10.00	--	
Lead	7439-92-1	mg/Kg	400	800	11	1700	56	120	0.340	0.0500	--	1.00	0.01	--
Magnesium	7439-95-4	mg/Kg	NE	NE	NE	NE	NE	NE	8.90	3.30	--	10.00	----	
Manganese	7439-96-5	mg/Kg	1,800	40	4300	450	4000	220	0.100	0.120	--	0.20	0.025	--
Mercury	7439-97-6	mg/Kg	9.4	40	NE	0.1	NE	0.3	--	--	0.008	--	----	0.01
Molybdenum	7439-98-7	mg/Kg	390	5800	NE	NE	NE	2	0.130	0.0800	--	1.00	0.1	--
Nickel	7440-02-0	mg/Kg	1500	22000	210	280	130	38	0.380	0.260	--	0.50	0.05	--
Potassium	7440-09-7	mg/Kg	NE	22000	NE	NE	NE	NE	2.50	9.10	--	25.00	--	
Selenium	7782-49-2	mg/Kg	390	5800	1.2	4.1	0.63	0.52	0.970	0.100	--	6.00	0.1	--
Silver	7440-22-4	mg/Kg	390	5800	4.2	NE	14	560	0.0600	0.0100	--	0.20	0.05	--
Sodium	7440-23-5	mg/Kg	1.3	16	NE	NE	NE	NE	48.0	10.0	--	25.00	--	
Thallium	7440-28-0	mg/Kg	0.78	12	NE	NE	NE	1	0.600	0.0500	--	2.00	0.1	--
Vanadium	7440-62-2	mg/Kg	390	5800	7.8	NE	280	2	0.100	0.270	--	1.00	0.2	--
Zinc	7440-66-6	mg/Kg	23000	350000	46	120	79	160	0.700	1.00	--	1.00	0.2	--

EPA Regional Screening Levels (RSLs), 2015. Available at: <http://www.epa.gov/region9/superfund/prg/>.

EPA Ecological Soil Screening Levels (Eco-SSLs), 2005 c/o Oak Ridge National Laboratory (ORNL) Ecological Benchmark Tool. Available at: http://rais.ornl.gov/tools/eco_search.php

mg/Kg milligrams per kilogram

NE None Established

The above surface soil criteria are not regulatory action levels, but are human health and ecological screening benchmarks used to determine when sites may warrant further evaluation. The exceedances of these benchmarks do not automatically indicate a response action is warranted.

START personnel will collect field duplicate and matrix spike/matrix spike duplicate (MS/MSD) samples and QA/QC samples as needed during the sampling activities. QA/QC samples will be collected as presented in Worksheet 20 of the QAPP.



U. S. EPA ENVIRONMENTAL RESPONSE TEAM

STANDARD OPERATING PROCEDURES

SOP: 2012
PAGE: 1 of 13
REV: 0.0
DATE: 02/18/00

SOIL SAMPLING

CONTENTS

- 1.0 SCOPE AND APPLICATION
- 2.0 METHOD SUMMARY
- 3.0 SAMPLE PRESERVATION, CONTAINERS, HANDLING, AND STORAGE
- 4.0 POTENTIAL PROBLEMS
- 5.0 EQUIPMENT
- 6.0 REAGENTS
- 7.0 PROCEDURES
 - 7.1 Preparation
 - 7.2 Sample Collection
 - 7.2.1 Surface Soil Samples
 - 7.2.2 Sampling at Depth with Augers and Thin Wall Tube Samplers
 - 7.2.3 Sampling at Depth with a Trier
 - 7.2.4 Sampling at Depth with a Split Spoon (Barrel) Sampler
 - 7.2.5 Test Pit/Trench Excavation
- 8.0 CALCULATIONS
- 9.0 QUALITY ASSURANCE/QUALITY CONTROL
- 10.0 DATA VALIDATION
- 11.0 HEALTH AND SAFETY
- 12.0 REFERENCES
- 13.0 APPENDIX
 - Figures



U. S. EPA ENVIRONMENTAL RESPONSE TEAM

STANDARD OPERATING PROCEDURES

SOP: 2012
PAGE: 2 of 13
REV: 0.0
DATE: 02/18/00

SOIL SAMPLING

1.0 SCOPE AND APPLICATION

The purpose of this standard operating procedure (SOP) is to describe the procedures for the collection of representative soil samples. Sampling depths are assumed to be those that can be reached without the use of a drill rig, direct-push, or other mechanized equipment (except for a back-hoe). Analysis of soil samples may determine whether concentrations of specific pollutants exceed established action levels, or if the concentrations of pollutants present a risk to public health, welfare, or the environment.

These are standard (i.e., typically applicable) operating procedures which may be varied or changed as required, dependent upon site conditions, equipment limitations or limitations imposed by the procedure. In all instances, the actual procedures used should be documented and described in an appropriate site report.

Mention of trade names or commercial products does not constitute U.S. Environmental Protection Agency (EPA) endorsement or recommendation for use.

2.0 METHOD SUMMARY

Soil samples may be collected using a variety of methods and equipment depending on the depth of the desired sample, the type of sample required (disturbed vs. undisturbed), and the soil type. Near-surface soils may be easily sampled using a spade, trowel, and scoop. Sampling at greater depths may be performed using a hand auger, continuous flight auger, a trier, a split-spoon, or, if required, a backhoe.

3.0 SAMPLE PRESERVATION, CONTAINERS, HANDLING, AND STORAGE

Chemical preservation of solids is not generally recommended. Samples should, however, be cooled and protected from sunlight to minimize any potential reaction. The amount of sample to be collected and proper sample container type are discussed in ERT/REAC SOP #2003 Rev. 0.0 08/11/94, *Sample Storage, Preservation and Handling*.

4.0 INTERFERENCES AND POTENTIAL PROBLEMS

There are two primary potential problems associated with soil sampling - cross contamination of samples and improper sample collection. Cross contamination problems can be eliminated or minimized through the use of dedicated sampling equipment. If this is not possible or practical, then decontamination of sampling equipment is necessary. Improper sample collection can involve using contaminated equipment, disturbance of the matrix resulting in compaction of the sample, or inadequate homogenization of the samples where required, resulting in variable, non-representative results.

5.0 EQUIPMENT



U. S. EPA ENVIRONMENTAL RESPONSE TEAM

STANDARD OPERATING PROCEDURES

SOP: 2012
PAGE: 3 of 13
REV: 0.0
DATE: 02/18/00

SOIL SAMPLING

Soil sampling equipment includes the following:

- Maps/plot plan
- Safety equipment, as specified in the site-specific Health and Safety Plan
- Survey equipment or global positioning system (GPS) to locate sampling points
- Tape measure
- Survey stakes or flags
- Camera and film
- Stainless steel, plastic, or other appropriate homogenization bucket, bowl or pan
- Appropriate size sample containers
- Ziplock plastic bags
- Logbook
- Labels
- Chain of Custody records and custody seals
- Field data sheets and sample labels
- Cooler(s)
- Ice
- Vermiculite
- Decontamination supplies/equipment
- Canvas or plastic sheet
- Spade or shovel
- Spatula
- Scoop
- Plastic or stainless steel spoons
- Trowel(s)
- Continuous flight (screw) auger
- Bucket auger
- Post hole auger
- Extension rods
- T-handle
- Sampling trier
- Thin wall tube sampler
- Split spoons
- Vehimeyer soil sampler outfit
 - Tubes
 - Points
 - Drive head
 - Drop hammer
 - Puller jack and grip
- Backhoe



U. S. EPA ENVIRONMENTAL RESPONSE TEAM

STANDARD OPERATING PROCEDURES

SOP: 2012
PAGE: 4 of 13
REV: 0.0
DATE: 02/18/00

SOIL SAMPLING

Reagents are not used for the preservation of soil samples. Decontamination solutions are specified in ERT/REAC SOP #2006 Rev. 0.0 08/11/94, *Sampling Equipment Decontamination*, and the site specific work plan.

7.0 PROCEDURES

7.1 Preparation

1. Determine the extent of the sampling effort, the sampling methods to be employed, and the types and amounts of equipment and supplies required.
2. Obtain necessary sampling and monitoring equipment.
3. Decontaminate or pre-clean equipment, and ensure that it is in working order.
4. Prepare schedules and coordinate with staff, client, and regulatory agencies, if appropriate.
5. Perform a general site survey prior to site entry in accordance with the site specific Health and Safety Plan.
6. Use stakes, flagging, or buoys to identify and mark all sampling locations. Specific site factors, including extent and nature of contaminant, should be considered when selecting sample location. If required, the proposed locations may be adjusted based on site access, property boundaries, and surface obstructions. All staked locations should be utility-cleared by the property owner or the On-Scene-Coordinator (OSC) prior to soil sampling; and utility clearance should always be confirmed before beginning work.

7.2 Sample Collection

7.2.1 Surface Soil Samples

Collection of samples from near-surface soil can be accomplished with tools such as spades, shovels, trowels, and scoops. Surface material is removed to the required depth and a stainless steel or plastic scoop is then used to collect the sample.

This method can be used in most soil types but is limited to sampling at or near the ground surface. Accurate, representative samples can be collected with this procedure depending on the care and precision demonstrated by the sample team member. A flat, pointed mason trowel to cut a block of the desired soil is helpful when undisturbed profiles are required. Tools plated with chrome or other materials should not be used. Plating is particularly common with garden implements such as potting trowels.

The following procedure is used to collect surface soil samples:



U. S. EPA ENVIRONMENTAL RESPONSE TEAM

STANDARD OPERATING PROCEDURES

SOP: 2012
PAGE: 5 of 13
REV: 0.0
DATE: 02/18/00

SOIL SAMPLING

1. Carefully remove the top layer of soil or debris to the desired sample depth with a pre-cleaned spade.
2. Using a pre-cleaned, stainless steel scoop, plastic spoon, or trowel, remove and discard a thin layer of soil from the area which came in contact with the spade.
3. If volatile organic analysis is to be performed, transfer the sample directly into an appropriate, labeled sample container with a stainless steel lab spoon, or equivalent and secure the cap tightly. Place the remainder of the sample into a stainless steel, plastic, or other appropriate homogenization container, and mix thoroughly to obtain a homogenous sample representative of the entire sampling interval. Then, either place the sample into appropriate, labeled containers and secure the caps tightly; or, if composite samples are to be collected, place a sample from another sampling interval or location into the homogenization container and mix thoroughly. When compositing is complete, place the sample into appropriate, labeled containers and secure the caps tightly.

7.2.2 Sampling at Depth with Augers and Thin Wall Tube Samplers

This system consists of an auger, or a thin-wall tube sampler, a series of extensions, and a "T" handle (Figure 1, Appendix A). The auger is used to bore a hole to a desired sampling depth, and is then withdrawn. The sample may be collected directly from the auger. If a core sample is to be collected, the auger tip is then replaced with a thin wall tube sampler. The system is then lowered down the borehole, and driven into the soil to the completion depth. The system is withdrawn and the core is collected from the thin wall tube sampler.

Several types of augers are available; these include: bucket type, continuous flight (screw), and post-hole augers. Bucket type augers are better for direct sample recovery because they provide a large volume of sample in a short time. When continuous flight augers are used, the sample can be collected directly from the flights. The continuous flight augers are satisfactory when a composite of the complete soil column is desired. Post-hole augers have limited utility for sample collection as they are designed to cut through fibrous, rooted, swampy soil and cannot be used below a depth of approximately three feet.

The following procedure is used for collecting soil samples with the auger:

1. Attach the auger bit to a drill rod extension, and attach the "T" handle to the drill rod.



U. S. EPA ENVIRONMENTAL RESPONSE TEAM

STANDARD OPERATING PROCEDURES

SOP: 2012
PAGE: 6 of 13
REV: 0.0
DATE: 02/18/00

SOIL SAMPLING

2. Clear the area to be sampled of any surface debris (e.g., twigs, rocks, litter). It may be advisable to remove the first three to six inches of surface soil for an area approximately six inches in radius around the drilling location.
3. Begin augering, periodically removing and depositing accumulated soils onto a plastic sheet spread near the hole. This prevents accidental brushing of loose material back down the borehole when removing the auger or adding drill rods. It also facilitates refilling the hole, and avoids possible contamination of the surrounding area.
4. After reaching the desired depth, slowly and carefully remove the auger from the hole. When sampling directly from the auger, collect the sample after the auger is removed from the hole and proceed to Step 10.
5. Remove auger tip from the extension rods and replace with a pre-cleaned thin wall tube sampler. Install the proper cutting tip.
6. Carefully lower the tube sampler down the borehole. Gradually force the tube sampler into the soil. Do not scrape the borehole sides. Avoid hammering the rods as the vibrations may cause the boring walls to collapse.
7. Remove the tube sampler, and unscrew the drill rods.
8. Remove the cutting tip and the core from the device.
9. Discard the top of the core (approximately 1 inch), as this possibly represents material collected before penetration of the layer of concern. Place the remaining core into the appropriate labeled sample container. Sample homogenization is not required.
10. If volatile organic analysis is to be performed, transfer the sample into an appropriate, labeled sample container with a stainless steel lab spoon, or equivalent and secure the cap tightly. Place the remainder of the sample into a stainless steel, plastic, or other appropriate homogenization container, and mix thoroughly to obtain a homogenous sample representative of the entire sampling interval. Then, either place the sample into appropriate, labeled containers and secure the caps tightly; or, if composite samples are to be collected, place a sample from another sampling interval into the homogenization container and mix thoroughly.

When compositing is complete, place the sample into appropriate, labeled containers and secure the caps tightly.



U. S. EPA ENVIRONMENTAL RESPONSE TEAM

STANDARD OPERATING PROCEDURES

SOP: 2012
PAGE: 7 of 13
REV: 0.0
DATE: 02/18/00

SOIL SAMPLING

11. If another sample is to be collected in the same hole, but at a greater depth, reattach the auger bit to the drill and assembly, and follow steps 3 through 11, making sure to decontaminate the auger and tube sampler between samples.
12. Abandon the hole according to applicable state regulations. Generally, shallow holes can simply be backfilled with the removed soil material.

7.2.3 Sampling with a Trier

The system consists of a trier, and a "T" handle. The auger is driven into the soil to be sampled and used to extract a core sample from the appropriate depth.

The following procedure is used to collect soil samples with a sampling trier:

1. Insert the trier (Figure 2, Appendix A) into the material to be sampled at a 0° to 45° angle from horizontal. This orientation minimizes the spillage of sample.
2. Rotate the trier once or twice to cut a core of material.
3. Slowly withdraw the trier, making sure that the slot is facing upward.
4. If volatile organic analyses are required, transfer the sample into an appropriate, labeled sample container with a stainless steel lab spoon, or equivalent and secure the cap tightly. Place the remainder of the sample into a stainless steel, plastic, or other appropriate homogenization container, and mix thoroughly to obtain a homogenous sample representative of the entire sampling interval. Then, either place the sample into appropriate, labeled containers and secure the caps tightly; or, if composite samples are to be collected, place a sample from another sampling interval into the homogenization container and mix thoroughly. When compositing is complete, place the sample into appropriate, labeled containers and secure the caps tightly.

7.2.4 Sampling at Depth with a Split Spoon (Barrel) Sampler

Split spoon sampling is generally used to collect undisturbed soil cores of 18 or 24 inches in length. A series of consecutive cores may be extracted with a split spoon sampler to give a complete soil column profile, or an auger may be used to drill down to the desired depth for sampling. The split spoon is then driven to its sampling depth through the bottom of the augured hole and the core extracted.

When split spoon sampling is performed to gain geologic information, all work should



U. S. EPA ENVIRONMENTAL RESPONSE TEAM

STANDARD OPERATING PROCEDURES

SOP: 2012
PAGE: 8 of 13
REV: 0.0
DATE: 02/18/00

SOIL SAMPLING

be performed in accordance with ASTM D1586-98, "Standard Test Method for Penetration Test and Split-Barrel Sampling of Soils".

The following procedures are used for collecting soil samples with a split spoon:

1. Assemble the sampler by aligning both sides of barrel and then screwing the drive shoe on the bottom and the head piece on top.
2. Place the sampler in a perpendicular position on the sample material.
3. Using a well ring, drive the tube. Do not drive past the bottom of the head piece or compression of the sample will result.
4. Record in the site logbook or on field data sheets the length of the tube used to penetrate the material being sampled, and the number of blows required to obtain this depth.
5. Withdraw the sampler, and open by unscrewing the bit and head and splitting the barrel. The amount of recovery and soil type should be recorded on the boring log. If a split sample is desired, a cleaned, stainless steel knife should be used to divide the tube contents in half, longitudinally. This sampler is typically available in 2 and 3 1/2 inch diameters. A larger barrel may be necessary to obtain the required sample volume.
6. Without disturbing the core, transfer it to appropriate labeled sample container(s) and seal tightly.

7.2.5 Test Pit/Trench Excavation

A backhoe can be used to remove sections of soil, when detailed examination of soil characteristics are required. This is probably the most expensive sampling method because of the relatively high cost of backhoe operation.

The following procedures are used for collecting soil samples from test pits or trenches:

1. Prior to any excavation with a backhoe, it is important to ensure that all sampling locations are clear of overhead and buried utilities.
2. Review the site specific Health & Safety plan and ensure that all safety precautions including appropriate monitoring equipment are installed as required.



U. S. EPA ENVIRONMENTAL RESPONSE TEAM

STANDARD OPERATING PROCEDURES

SOP: 2012
PAGE: 9 of 13
REV: 0.0
DATE: 02/18/00

SOIL SAMPLING

3. Using the backhoe, excavate a trench approximately three feet wide and approximately one foot deep below the cleared sampling location. Place excavated soils on plastic sheets. Trenches greater than five feet deep must be sloped or protected by a shoring system, as required by OSHA regulations.
4. A shovel is used to remove a one to two inch layer of soil from the vertical face of the pit where sampling is to be done.
5. Samples are taken using a trowel, scoop, or coring device at the desired intervals. Be sure to scrape the vertical face at the point of sampling to remove any soil that may have fallen from above, and to expose fresh soil for sampling. In many instances, samples can be collected directly from the backhoe bucket.
6. If volatile organic analyses are required, transfer the sample into an appropriate, labeled sample container with a stainless steel lab spoon, or equivalent and secure the cap tightly. Place the remainder of the sample into a stainless steel, plastic, or other appropriate homogenization container, and mix thoroughly to obtain a homogenous sample representative of the entire sampling interval. Then, either place the sample into appropriate, labeled containers and secure the caps tightly; or, if composite samples are to be collected, place a sample from another sampling interval into the homogenization container and mix thoroughly. When compositing is complete, place the sample into appropriate, labeled containers and secure the caps tightly.
7. Abandon the pit or excavation according to applicable state regulations. Generally, shallow excavations can simply be backfilled with the removed soil material.

8.0 CALCULATIONS

This section is not applicable to this SOP.

9.0 QUALITY ASSURANCE/QUALITY CONTROL

There are no specific quality assurance (QA) activities which apply to the implementation of these procedures. However, the following QA procedures apply:

1. All data must be documented on field data sheets or within site logbooks.
2. All instrumentation must be operated in accordance with operating instructions as supplied by the manufacturer, unless otherwise specified in the work plan. Equipment checkout and calibration



U. S. EPA ENVIRONMENTAL RESPONSE TEAM

STANDARD OPERATING PROCEDURES

SOP: 2012
PAGE: 10 of 13
REV: 0.0
DATE: 02/18/00

SOIL SAMPLING

activities must occur prior to sampling/operation, and they must be documented.

10.0 DATA VALIDATION

This section is not applicable to this SOP.

11.0 HEALTH AND SAFETY

When working with potentially hazardous materials, follow U.S. EPA, OSHA and corporate health and safety procedures, in addition to the procedures specified in the site specific Health & Safety Plan..

12.0 REFERENCES

Mason, B.J. 1983. Preparation of Soil Sampling Protocol: Technique and Strategies. EPA-600/4-83-020.

Barth, D.S. and B.J. Mason. 1984. Soil Sampling Quality Assurance User's Guide. EPA-600/4-84-043.

U.S. Environmental Protection Agency. 1984 Characterization of Hazardous Waste Sites - A Methods Manual: Volume II. Available Sampling Methods, Second Edition. EPA-600/4-84-076.

de Vera, E.R., B.P. Simmons, R.D. Stephen, and D.L. Storm. 1980. Samplers and Sampling Procedures for Hazardous Waste Streams. EPA-600/2-80-018.

ASTM D 1586-98, ASTM Committee on Standards, Philadelphia, PA.



U. S. EPA ENVIRONMENTAL RESPONSE TEAM

STANDARD OPERATING PROCEDURES

SOP: 2012
PAGE: 11 of 13
REV: 0.0
DATE: 02/18/00

SOIL SAMPLING

APPENDIX A
Figures
SOP #2012
February 2000



U. S. EPA ENVIRONMENTAL RESPONSE TEAM

STANDARD OPERATING PROCEDURES

SOP: 2012
PAGE: 12 of 13
REV: 0.0
DATE: 02/18/00

SOIL SAMPLING

FIGURE 1. Sampling Augers

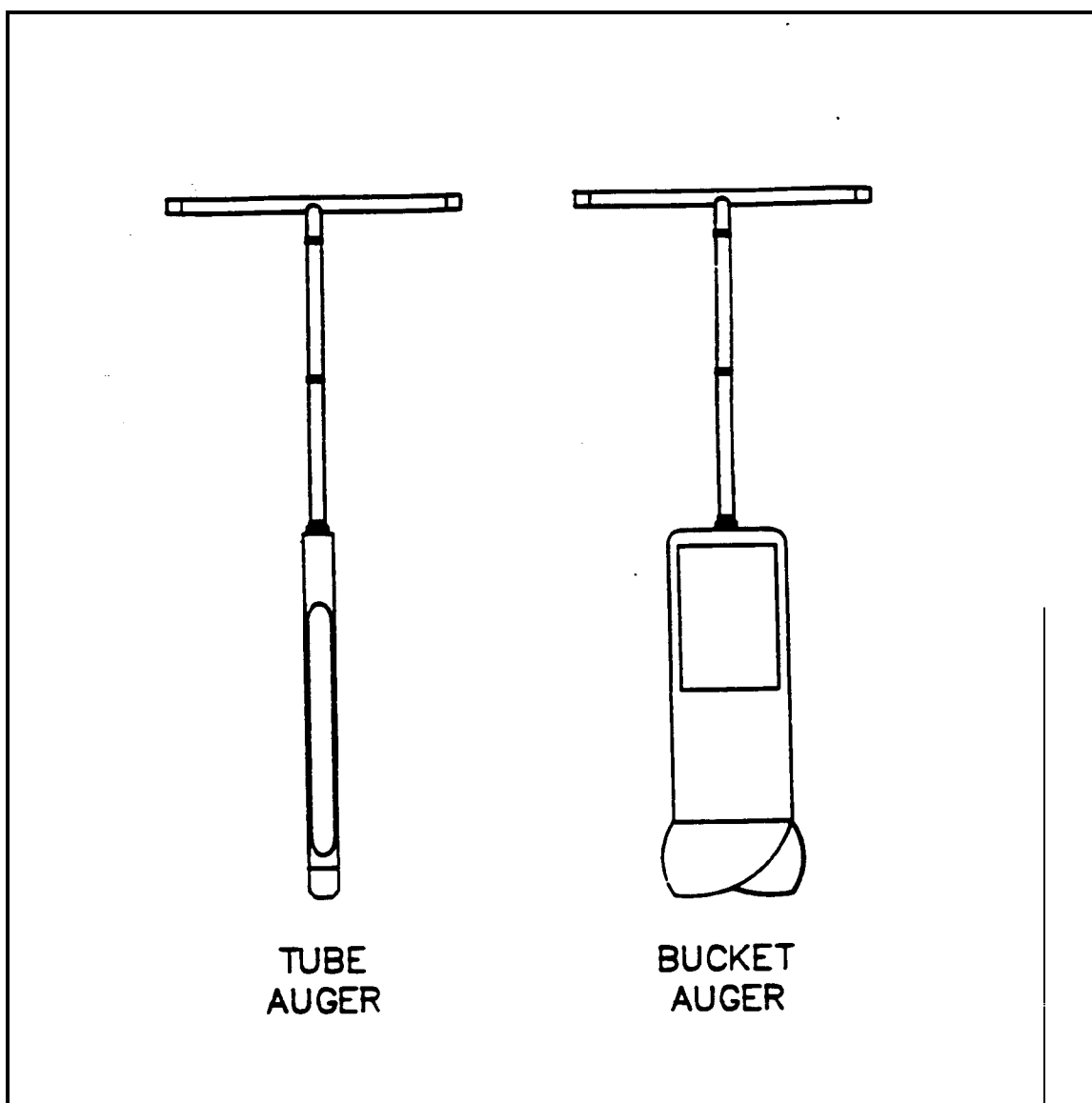



U. S. EPA ENVIRONMENTAL RESPONSE TEAM

STANDARD OPERATING PROCEDURES

SOP: 2012
PAGE: 13 of 13
REV: 0.0
DATE: 02/18/00

SOIL SAMPLING

FIGURE 2. Sampling Trier

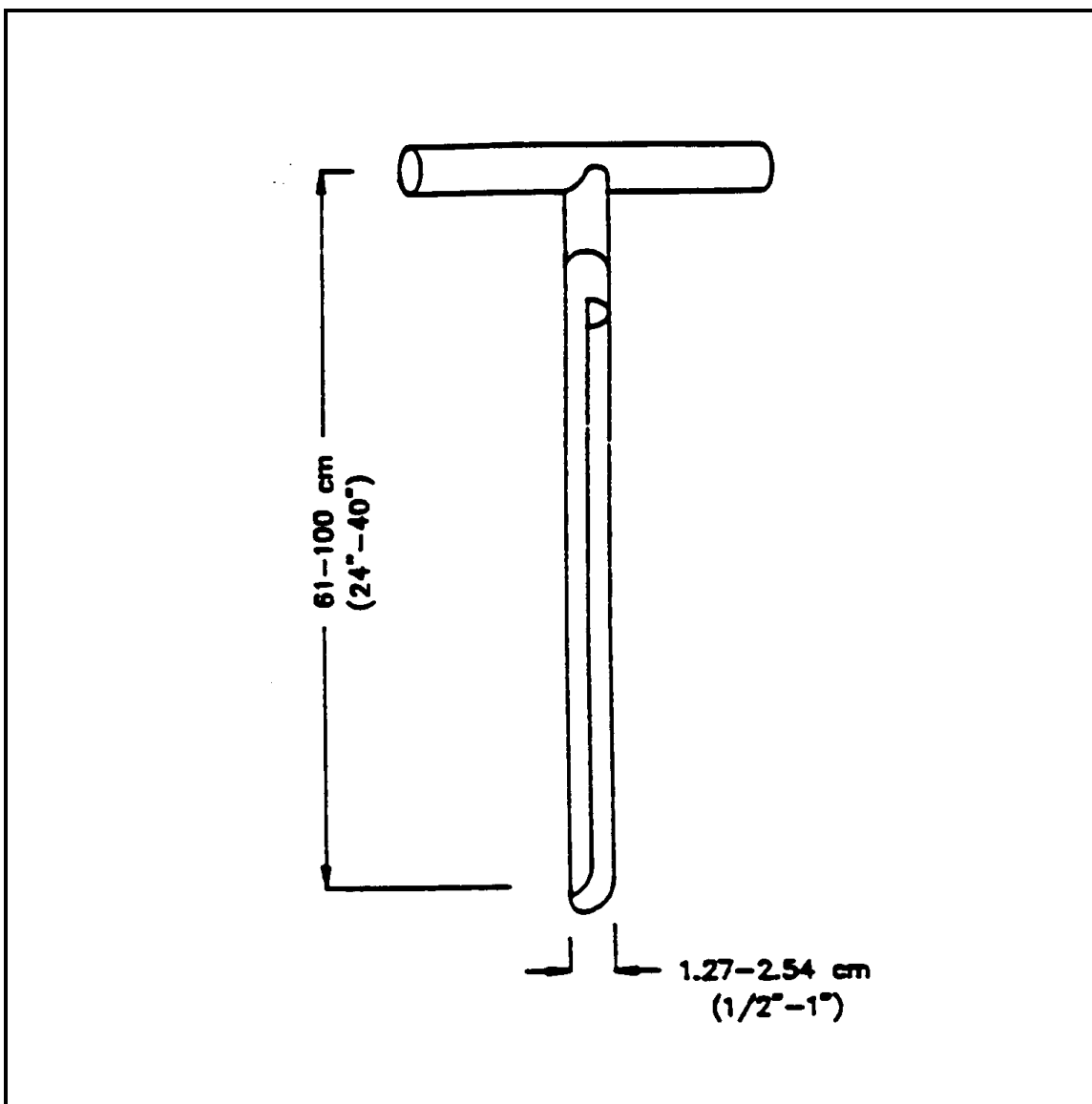

**Gold King Mine Release
Sampling and Analysis Plan/Quality Assurance Project Plan**

To: Craig Myers
From: Mark Blanchard
CC: Joyce Ackerman, Richard Graham, Joyel Dhieux, Dan Wall
TDD#: 0001/1508-04
Date: 8/20/2015
DCN: W0267.1E.00546
Re: Addendum 4 to Gold King Mine Release SAP/QAPP – Biological Sampling

Comments: This is Addendum 4 to the Gold King Mine Release SAP/QAPP, dated 8/20/15. This Addendum provides the following:

1. Written protocol for collecting biological water samples from within the area affected by the Gold King Mine release.
2. An excerpt from *EPA National Rivers and Streams Assessment Field Operations Manual* for biological water sampling that documents the purpose and scope of the NRSA program.

Purpose and Scope

START will collect surface water samples to characterize depositional impacts from the Gold King Mine release. Samples will be collected from within the area of potential impact from the release.

Sampling and Field QC Procedures

Sampling will include collection of surface water samples at biased locations in areas of potential contamination. Sample points will be determined in the field based on locations directed by the OSC. Locations may include previously defined stations or new stations identified for biological assessment purposes. Stations will be logged with a Global Positioning System (GPS) device and/or denoted in the field logbook to be used for mapping purposes and to document sample locations selected in the field. If sampling locations become inaccessible, alternate sampling locations which provide similarly adequate or sufficient data as the original will be identified and sampled based upon the best judgment of the inspector/sampler or as directed by the OSC, if necessary.

Sample collection procedures will be based on those in the EPA National Rivers and Streams Assessment Field Operations Manual (FOM) (EPA-841-B-07-009) for biological sampling (EPA, 2009a). Requirements for the sample container, volume, preservation, and QC samples are presented in the FOM (EPA, 2009a). START personnel will collect field duplicate and QA/QC samples as needed during the sampling activities based on the criteria outlined in the FOM (EPA, 2009a). Samples may be analyzed for biologicals using the methods described in the FOM and the National Rivers and Streams Assessment: Laboratory Methods Manual (EPA-841-B-07-010) (EPA, 2009a; 2009b).

Supporting documents that may be used in conjunction with the aforementioned sampling and analytical guidance include: National Rivers and Streams Assessment: Quality Assurance Project Plan (EPA-841-B-07-007) (EPA, 2010) and National Rivers and Streams Assessment: Site Evaluation Guidelines (EPA-841-B-07-008) (EPA, 2009c). START personnel may refer to the Sampling and Analysis Plan/Quality Assurance Project Plan for Gold King Mine Blowout, Silverton, San Juan County, Colorado (WESTON, 2015) for project-specific quality assurance and sampling procedures not addressed in these documents.

References

EPA, 2009a. *National Rivers and Streams Assessment: Field Operations Manual*. Office of Water Office and Office of Environmental Information. EPA-841-B-07-009. April 2009.

EPA, 2009b. *National Rivers and Streams Assessment: Laboratory Methods Manual*. Office of Water Office and Office of Environmental Information. EPA-841-B-07-010. Revision No.1. November 2009.

EPA, 2009c. *National Rivers and Streams Assessment: Site Evaluation Guidelines*. Office of Water Office and Office of Environmental Information. EPA-841-B-07-008. February 2009.

EPA, 2010. *National Rivers and Streams Assessment: Quality Assurance Project Plan*. Office of Water Office and Office of Environmental Information. EPA 841-B-07-007. December 2010.

WESTON, 2015. *Sampling and Analysis Plan/Quality Assurance Project Plan for Gold King Mine Blowout, Silverton, San Juan County, Colorado*. August 2015.

NOTICE

The intention of the National Rivers and Streams Assessment project is to provide a comprehensive “State of the Flowing Waters” assessment for rivers and streams across the United States. The complete documentation of overall project management, design, methods, and standards is contained in four companion documents:

- National Rivers and Streams Assessment: *Quality Assurance Project Plan (EPA-841-B-07-007)*
- National Rivers and Streams Assessment: *Site Evaluation Guidelines (EPA-841-B-07-008)*
- National Rivers and Streams Assessment: *Field Operations Manual (EPA-841-B-07-009)*
- National Rivers and Streams Assessment: *Laboratory Methods Manual (EPA-841-B-07-010)*

This document (*Field Operations Manual*) contains a brief introduction and procedures to follow at the base location and on-site, including methods for sampling water chemistry (grabs and *in situ* measurements), periphyton, benthic macroinvertebrates, sediment enzymes, fish composition, fish tissue (at non-wadeable sites), a fecal indicator, and physical habitat. These methods are based on the guidelines developed and followed in the Western Environmental Monitoring and Assessment Program (Baker, et al., 1997), the methods outlined in Concepts and Approaches for the Bioassessment of Non-wadeable Streams and Rivers (Flotemersch, et al., 2006), and methods employed by several key states that were involved in the planning phase of this project. Methods described in this document are to be used specifically in work relating to the National Rivers and Streams Assessment. All Project Cooperators must follow these guidelines. Mention of trade names or commercial products in this document does not constitute endorsement or recommendation for use. Details on specific methods for site evaluation and sample processing can be found in the appropriate companion document.

The citation for this document is:

USEPA. 2007. National Rivers and Streams Assessment: Field Operations Manual. EPA-841-B-07-009. U.S. Environmental Protection Agency, Washington, DC.