



## Beach Notification Database User Guide (For Notification Schema v2.1)

**Contract Number GS-35F-4797H**

**Task Order # 1518**

**TDD 10.02 eBeaches**

Version 2.2.1

July 21, 2010

---

## Table of Contents

Table of Contents.....	iii
List of Exhibits.....	iv
Revision Log .....	v
1 Introduction .....	1
1.1 Document Purpose.....	1
2 How to Submit Data .....	2
2.1 Submit Data via CDX.....	2
2.2 Detailed XML Processing Notes .....	4
3 How to Understand the XML Submission .....	5
3.1 Elements in the XML Schema and XML Files .....	5
3.2 Use of Effective Date and Status Indicator Data Elements .....	38
4 How to Decode the Error Messages.....	40
4.1 System Generated Error Messages.....	40
4.2 Common Causes of Error Messages .....	43
4.3 Oracle Generated Error Messages .....	47
5 How to Understand Beaches that are Similar Points of Access .....	48
6 Appendix A—Schema Graphics .....	49
7 Appendix B—Example XML File.....	57
8 Appendix C—Procedure Type Codes.....	62
9 Appendix D—Water Body Codes .....	69
10 Appendix E—Horizontal Collection.....	70
11 Appendix F—Addition Notifications.....	72
12 Appendix G—Pollution Source Identification .....	75
13 Appendix H—Data Entry Forms .....	78
14 Appendix I—Summary Reports .....	81
15 <a href="#">Appendix J—CDX Messages</a> .....	87

---

## List of Exhibits

Exhibit 2-1 Data Transfer Diagram .....	4
Exhibit 4-1 PRAWN Error Messages .....	40
Exhibit 4-2 Common Error Messages.....	44
Exhibit 6-1 Beach Data Submission .....	49
Exhibit 6-2 Organization Detail.....	50
Exhibit 6-3 Organization Person Detail.....	51
Exhibit 6-4 Beach Name Detail .....	52
Exhibit 6-5 Beach Activity Detail.....	54
Exhibit 6-6 Beach Role Detail.....	55
Exhibit 6-7 Beach Coordinate Detail.....	55
Exhibit 6-8 Beach Procedure Detail.....	56
Exhibit 6-9 Year Completion Indicators .....	56
Exhibit 9-1 Water Body Name .....	69
Exhibit 9-2 Water Body Type.....	69
Exhibit 10-1 Horizontal Collection Method Name .....	70
Exhibit 10-2 Horizontal Collection Reference Datum Name.....	71
Exhibit 11-1 Example Notification XML Document .....	72
Exhibit 11-2 Custom XML Generation .....	73
Exhibit 12-1 Access Database .....	75
Exhibit 12-2 XML Schema.....	77
Exhibit 13-1 Forms.....	78
Exhibit 13-2 Main Menu .....	79
Exhibit 13-3 Return to Main Menu .....	80
Exhibit 14-1 Reports .....	81
Exhibit 14-2 Actions .....	82
Exhibit 14-3 Attributes .....	83
Exhibit 14-4 Monitoring .....	84
Exhibit 14-5 Pollution Source .....	85
Exhibit 14-6 Pollution Source (cont.) .....	86
Exhibit 15-1 Your CDX eBeaches Data Submission.....	87
Exhibit 15-2 Validation Message .....	88
Exhibit 15-3 Final Email .....	89

---

## Revision Log

Date	Version No.	Description	Author	Reviewer	Review Date
7/21/10	2.2.1	Added Appendix J CDX Messages	EMR		

---

# 1 Introduction

## 1.1 Document Purpose

---

The purpose of this document is to introduce representatives from state beach programs to the **PR**ogram tracking, beach **A**dvisories, **W**ater quality standards, and **N**utrients (PRAWN) database. All state beach program and notification (advisory and closing) data will be stored in PRAWN. In particular, this guide is intended for officials from State beach programs, the EPA's Beaches program, and any database administrators in charge of a state database.

The document can be used to explain the following about beach data submissions to EPA:

- **Error! Reference source not found.**—explanation on how data is transferred from the originator (in most cases State Beach programs) through CDX to the EPA. Details about the transfers are separated into a second subsection for a more technical audience.
- **Error! Reference source not found.**—explanation of the data that needs to be submitted to EPA and how that data should be formed within the XML document. Each section of the XML schema is explained in detail, and a specific section is devoted to explaining the use of the effective date and status indicator elements.

**Error! Reference source not found.**—explanation of the errors that the PRAWN database will produce due to logic and/or technical errors in the path between the creation of the XML document and the loading of data into PRAWN.

## 2 How to Submit Data

States that need to submit Beach information to EPA need to take advantage of EPA's Central Data exchange (CDX) initiative to submit their data through a website.

### 2.1 Submit Data via CDX

The Central Data eXchange (CDX) is an Office of Environmental Information (OEI) initiative to provide a single point of entry for incoming data into EPA. CDX will maintain a set of web pages where, once registered, States can log in and upload data files to EPA. Additional information on CDX and the Exchange Network can be found at: <http://www.epa.gov/cdx>.

The diagram in Exhibit 2-1 describes how data can be submitted from a State database to EPA's PRAWN database via CDX. For information on how to create a custom data submission, please see Section **Error! Reference source not found.** The following table describes the steps involved in the process:

State Steps	CDX Automated Steps	PRAWN Automated Steps
1. Register in 3 places: A) Register with CDX via the CDX HelpDesk. Send an email to <a href="mailto:helpdesk@epacdx.net">helpdesk@epacdx.net</a> or call 888-890-1995 B) Register any new beaches with the EPA to create a unique EPA Beach ID for each beach in the state. C) Register water quality stations in WQX submissions ( <a href="http://www.epa.gov/storet/wqx/index.html">http://www.epa.gov/storet/wqx/index.html</a> )		
2. Create an XML document containing the appropriate data (see Chapter <b>Error! Reference source not found. Error! Reference source not found.</b> for the data to be included) using a local copy of the schema.		
3. Upload the XML document from a local State computer to CDX via CDX's website: <a href="https://cdx.epa.gov/SSL/cdx/login.asp">https://cdx.epa.gov/SSL/cdx/login.asp</a>		
	4. Archive the file and validate the XML document against the schema. If errors are found, send a CDX error log to the State user; otherwise, skip to Step 6.	
5. Visit MyCDX Inbox for error/success log messages. If a CDX error log is received, go back to Step 2 and fix the errors.		
	6. Once the XML document passes validation, add the header information and transfer the XML document to the PRAWN XML Parser.	

State Steps	CDX Automated Steps	PRAWN Automated Steps
		7. Validate the XML document against the business rules. If errors are found, create an error log to CDX; otherwise, skip to Step 10.
	8. If a PRAWN error log is created, pass it along to the State.	
9. Make a second visit to MyCDX Inbox. If a PRAWN error log is received, go back to Step 2 and fix the errors.		
		10. When the XML file is received that passes the business rules, parse the data into the database and create a success log.
	11. If a PRAWN success log is created, pass it along to the State.	

---

### Exhibit 2-1 Data Transfer Diagram

Begin on the upper left side, labeled “State Database”, and follow the flow of arrows through the “PRAWN Database”.

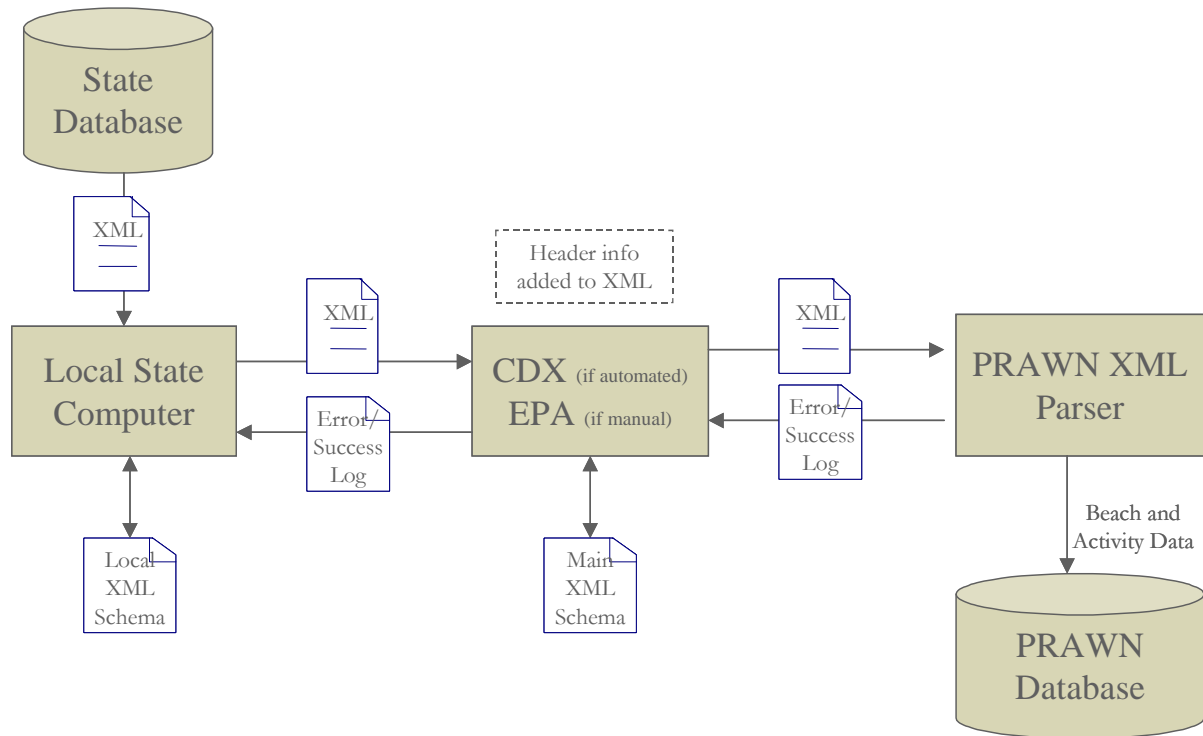

## 2.2 Detailed XML Processing Notes

---

The following technical notes support the processes described in the previous two sections of this chapter:

- Empty tags such as `<OrganizationCode></OrganizationCode>` or `<OrganizationCode/>` will not be accepted.
- If the XML submission passes the validation routine, information about the submission will be inserted into the following four XML tags: `SubmissionIdentifier`, `SubmittingAgencyIdentifier`, `SubmittingUserIdentifier`, and `SubmissionDate`. These four tags are enclosed in tags labeled `HeaderInformation`. The `HeaderInformation` tag must appear second in the file after the `BeachDataSubmission` tag.
- When the XML load process is complete, any errors will be written to an error file of the same name, with a `.log` extension instead of the `.xml` extension.



---

## 3 How to Understand the XML Submission

This chapter describes the XML data files and the associated XML schema to be used for the PRAWN database.

### 3.1 Elements in the XML Schema and XML Files

---

The XML schema for the data submissions to PRAWN provides a template for the XML files to be submitted. This schema describes the data elements to be included in the XML document and is also used to validate it. Files are accepted or rejected based on their conformity to the schema. A graphical version of this schema is provided in Appendix A and an example XML document is provided in Appendix B of this document. Please refer to these appendices when creating an XML document.

This section contains descriptions of the data elements in the PRAWN XML Schema. For each table in the following sections, the following information is provided:

- Data Element: The name of the data element stored in the XML data file.
- XML Tag Name: The XML key associated with the data element.
- XML Data Type: The XML data type for this element.
- Length: The maximum length for the data element for character and numeric data types.
- Req'd (Y/N): This value indicates if the column is required in the XML data file. Please note that empty tags such as <OrganizationCode></OrganizationCode> or <OrganizationCode/> will not be accepted when the element is not required.
- Comments: Additional comments related to the XML data element.

For questions on the conventions and formats used in the schema, reference the Exchange Network's *XML Schema Design Rules and Conventions*<sup>1</sup>.

---

<sup>1</sup> The Exchange Network's *XML Schema Design Rules and Conventions* can be found here:  
[http://www.exchangenetwork.net/dev\\_schema/drc.htm](http://www.exchangenetwork.net/dev_schema/drc.htm)

### 3.1.1 Organization Information

The organization information section of the XML submission contains data related to the organizations involved in the Beach Act Grant Program, such as organization code, organization name, organization description, and contact information. These data elements will be included in the XML file when organization data needs to be added or updated in the PRAWN database.

All XML elements in this section are located in the following position on the XML element hierarchy—“BeachDataSubmission/OrganizationDetail/”.

Data Element	XML Tag Name	XML Data Type	Req'd (Y/N)	Length	Access Table Mapping	Comment
Organization Identifier <i>Example:</i> 987654321098	OrganizationIdentifier	STRING	Y	12	ORGANIZATION.ID, PERSON.FK_ORGANIZATION_ID, MAILING_ADDRESS.FK_ORGANIZATION_ID, ELECTRONIC_ADDRESS.FK_ORGANIZATION_ID, BEACH_ORGANIZATION_ROLE_ASSIGN.FK_ORGANIZATION_ID	An organization refers to the entity associated with a Notification submitted to PRAWN. The type of entity is noted in the 'Organization Type Code' field.  EPA will maintain a list of valid Organization Identifiers for all organizations that are stored in the PRAWN database. These identifiers must be unique, as they will be used to update organization-level data.
Organization Type Code <i>Example:</i> STATE_AGNC Y	OrganizationNameDetail/OrganizationTypeCode	STRING	Y	12	ORGANIZATION.ORGANIZATION_CODE	This value must be set to one of the following: <ul style="list-style-type: none"> <li>■ STATE_AGENCY (<i>State Agency</i>)</li> <li>■ EPA (<i>U.S. EPA</i>)</li> <li>■ PUB_INT_GRP (<i>Public Interest Group</i>)</li> <li>■ LOCAL_GOV (<i>Local Government</i>)</li> <li>■ PRIVATE (<i>Private Company</i>)</li> <li>■ OW (<i>U.S. EPA Office of Water</i>)</li> <li>■ OW_DIV (<i>U.S. EPA Office of Water Division</i>)</li> <li>■ OW_BRANCH (<i>U.S. EPA Office of Water Branch</i>)</li> </ul> This value is required if any organization name information is included in the XML data file.
Organization Name <i>Example:</i> Maine Department of Environmental Protection	OrganizationNameDetail/OrganizationName	STRING	Y	60	ORGANIZATION.NAME	This value is required if any organization name information is included in the XML data file

Data Element	XML Tag Name	XML Data Type	Req'd (Y/N)	Length	Access Table Mapping	Comment
Organization Description Text <i>Example: Maine DEP</i>	OrganizationNameDetail/OrganizationDescriptionText	STRING	N	255	ORGANIZATION.DESCRPTION	
Organization Abbreviation Text <i>Example: MDEP</i>	OrganizationNameDetail/OrganizationAbbreviationText	STRING	N	30	ORGANIZATION.ABBREVIATION	
Organization Mailing Address Type Code <i>Example: MAILING</i>	OrganizationMailingAddressDetail/MailingAddressTypeCode	STRING	Y	12	MAILING_ADDRESS.MAILING_ADDRESS_CODE	This value must be set to one of the following: <ul style="list-style-type: none"> <li>SHIPPING (<i>Shipping Address</i>)</li> <li>MAILING (<i>Mailing Address</i>)</li> <li>OTHER (<i>Other Address</i>)</li> </ul> This value is required if any organization mailing address information is included in the XML data file.
Organization Mailing Address Street Line 1 Text <i>Example: 14 Main Rd.</i>	OrganizationMailingAddressDetail/MailingAddressStreetLine1Text	STRING	Y	100	MAILING_ADDRESS.LINE_1	This value is required if any organization mailing address information is included in the XML data file.
Organization Mailing Address Street Line 2 Text <i>Example: Suite 4</i>	OrganizationMailingAddressDetail/MailingAddressStreetLine2Text	STRING	N	100	MAILING_ADDRESS.LINE_2	
Organization Mailing Address Street Line 3 Text <i>Example: Building 12</i>	OrganizationMailingAddressDetail/MailingAddressStreetLine3Text	STRING	N	100	MAILING_ADDRESS.LINE_3	
Organization Mailing Address City Text <i>Example: Augusta</i>	OrganizationMailingAddressDetail/MailingAddressCityName	STRING	Y	50	MAILING_ADDRESS.CITY	This value is required if any organization mailing address information is included in the XML data file.
Organization Mailing Address State Code <i>Example: ME</i>	OrganizationMailingAddressDetail/StateCode	STRING	Y	2	MAILING_ADDRESS.STATE_POSTAL_CODE	This value is required if any organization mailing address information is included in the XML data file.  This value must be a valid 2-character State Postal Code.

Data Element	XML Tag Name	XML Data Type	Req'd (Y/N)	Length	Access Table Mapping	Comment
Organization Mailing Address Zip Code <i>Example:</i> 04333	OrganizationMailingAddressDetail/AddressPostalCode	STRING	Y	12	MAILING_ADDRESS.ZIP_CODE	This value is required if any organization mailing address information is included in the XML data file.  This value must be in one of the following numeric formats: <ul style="list-style-type: none"> <li>■ #####</li> <li>or</li> <li>■ #####-####</li> </ul>
Organization Mailing Address Effective Date <i>Example:</i> 2003-01-01T00:00:00	OrganizationMailingAddressDetail/MailingAddressEffectiveDate	DATE	Y		MAILING_ADDRESS.EFFECTIVE_DATE	This value is required if any organization mailing address information is included in the XML data file.  The date should be entered in the XML file in the following format: YYYY-MM-DDTHH:MI:SS  This value should be set to the date on which the mailing address information became effective or will become effective.  Please see Section 3.2 Use of Effective Date and Status Indicator Data Elements for more information.
Organization Mailing Address Status Indicator <i>Example:</i> ACTIVE	OrganizationMailingAddressDetail/MailingAddressStatusIndicator	STRING	Y	8	MAILING_ADDRESS.STATUS	This value is required if any organization mailing address information is included in the XML data file.  This value must be set to "ACTIVE" or "INACTIVE".  Please see Section 3.2 Use of Effective Date and Status Indicator Data Elements for more information.
Organization Electronic Address Type Code <i>Example:</i> URL	OrganizationElectronicAddressDetail/ElectronicAddressTypeCode	STRING	Y	12	ELECTRONIC_ADDRESS.ELECTRONIC_ADDRESS_CODE	This value must be set to one of the following: <ul style="list-style-type: none"> <li>■ EMAIL (<i>E-mail</i>)</li> <li>■ URL (<i>URL</i>)</li> <li>■ OTHER (<i>Other</i>)</li> </ul> This value is required if any organization electronic address information is included in the XML data file.
Organization Electronic Address Text <i>Example:</i> <a href="http://www.maine.gov/dep/blwq/beach.htm">http://www.maine.gov/dep/blwq/beach.htm</a>	OrganizationElectronicAddressDetail/ElectronicAddressText	STRING	Y	255	ELECTRONIC_ADDRESS.ADDRESS	This value is required if any organization electronic address information is included in the XML data file.

Data Element	XML Tag Name	XML Data Type	Req'd (Y/N)	Length	Access Table Mapping	Comment
Organization Electronic Address Effective Date <i>Example:</i> 2003-01-01T00:00:00	OrganizationElectronicAddressDetail/EffectiveDate	DATE	Y		ELECTRONIC_ADDRESS.EFFECTIVE_DATE	This value is required if any organization electronic address information is included in the XML data file.  The date should be entered in the XML file in the following format: YYYY-MM-DDTHH:MI:SS  This value should be set to the date on which the electronic address information became effective or will become effective.  Please see Section 3.2 Use of Effective Date and Status Indicator Data Elements for more information.
Organization Electronic Address Status Indicator <i>Example:</i> ACTIVE	OrganizationElectronicAddressDetail/ElectronicAddressStatusIndicator	STRING	Y	8	ELECTRONIC_ADDRESS.STATUS	This value is required if any organization electronic address information is included in the XML data file.  This value must be set to "ACTIVE" or "INACTIVE".  Please see Section 3.2 Use of Effective Date and Status Indicator Data Elements for more information.
Organization Telephone Type Code <i>Example:</i> VOICE	OrganizationTelephoneDetail/TelephoneTypeCode	STRING	Y	12	TELEPHONE.TELEPHONE_CODE	This value must be set to one of the following: <ul style="list-style-type: none"> <li>■ FAX (Fax)</li> <li>■ VOICE (Voice)</li> <li>■ PAGER (Pager)</li> <li>■ CELL (Cellular/Mobile)</li> <li>■ OTHER (Other)</li> </ul> This value is required if any organization telephone information is included in the XML data file.
Organization Telephone Number <i>Example:</i> 207-287-3901	OrganizationTelephoneDetail/TelephoneNumberText	STRING	Y	12	TELEPHONE.TELEPHONE_NUMBER	This value is required if any organization telephone information is included in the XML data file.  This value must be in the following alphanumeric format: <ul style="list-style-type: none"> <li>■ XXX-XXX-XXXX</li> </ul>

---

Data Element	XML Tag Name	XML Data Type	Req'd (Y/N)	Length	Access Table Mapping	Comment
Organization Telephone Effective Date <i>Example:</i> 2003-01-01T00:00:00	OrganizationTelephoneDetail/EffectiveDate	DATE	Y		TELEPHONE.EFFECTIVE_DATE	This value is required if any organization telephone information is included in the XML data file.  The date should be entered in the XML file in the following format: YYYY-MM-DDTHH:MI:SS  This value should be set to the date on which the telephone information became effective or will become effective.  Please see Section 3.2 Use of Effective Date and Status Indicator Data Elements for more information.
Organization Telephone Status Indicator <i>Example:</i> ACTIVE	OrganizationTelephoneDetail/StatusIndicator	STRING	Y	8	TELEPHONE.STATUS	This value is required if any organization telephone information is included in the XML data file.  This value must be set to "ACTIVE" or "INACTIVE".  Please see Section 3.2 Use of Effective Date and Status Indicator Data Elements for more information.

---

### 3.1.2 Person Information

The person information section of the XML submission contains data related to the people associated with the beaches overseen by the National Beach Watch Program. Examples of this data include person identifier code, name, title, and contact information. These data elements will be included in the XML file when person data needs to be added or updated in the PRAWN database.

In the XML schema, each person is affiliated with exactly one organization. However, each organization can be associated with many people.

All XML elements in this section are located in the following position on the XML element hierarchy—"BeachDataSubmission/OrganizationDetail/OrganizationPersonDetail/".

Data Element	XML Tag Name	XML Data Type	Req'd (Y/N)	Length	Access Table Mapping	Comment
Person Identifier <i>Example: JOSM</i>	PersonIdentifier	STRING	Y	12	PERSON.ID, BEACH_PERSON_ROLE_ASSIGN.FK_PERSON_ID, ELECTRONIC_ADDRESS.FK_PERSON_ID, MAILING_ADDRESS.FK_PERSON_ID, TELEPHONE.FK_PERSON_ID	Submitting organizations will need to maintain a list of valid Person Identifiers for all people that are stored in the PRAWN database. These identifiers must be unique within each organization, as they will be used to update organization-level data. (For example, with an organization there can only be 1 person identified as "JOSM", but there could be another person identified as "JOSM" in another organization.)
Person Status Indicator <i>Example: ACTIVE</i>	PersonNameDetail/PersonStatusIndicator	STRING	Y	8	PERSON.ACTIVE	This value if required if any person name information is included in the XML data file.  This value must be set to "ACTIVE" or "INACTIVE".
Person First Name <i>Example: John</i>	PersonNameDetail/FirstName	STRING	Y	50	PERSON.FIRST_NAME	This value if required if any person name information is included in the XML data file.
Person Last Name <i>Example: Smith</i>	PersonNameDetail/LastName	STRING	Y	50	PERSON.LAST_NAME	This value if required if any person name information is included in the XML data file.

Data Element	XML Tag Name	XML Data Type	Req'd (Y/N)	Length	Access Table Mapping	Comment
Person Middle Initial <i>Example: S</i>	PersonNameDetail/PersonMiddleInitial	STRING	N	2	PERSON.MIDDLE_INITIAL	The two characters in the 'Person Middle Initial' can be used as needed by the submitting state. For example, if there are two people within a given organization called 'Bob A Smith', using the second letter of the Middle Name as the second letter of the 'Person Middle Initial' can be a valuable method used to differentiate between the two. Or, a period can be inserted after the first letter. Or, the second space can be left blank.
Person Suffix <i>Example: Jr.</i>	PersonNameDetail/NameSuffixText	STRING	N	5	PERSON.SUFFIX	
Person Title <i>Example: Mr.</i>	PersonNameDetail/NamePrefixText	STRING	N	60	PERSON.TITLE	
Person Mailing Address Type Code <i>Example: SHIPPING</i>	PersonMailingAddressDetail/MailingAddressTypeCode	STRING	Y	12	MAILING_ADDRESS.MAILING_ADDRESS_CODE	This value must be set to one of the following: <ul style="list-style-type: none"> <li>■ SHIPPING (<i>Shipping Address</i>)</li> <li>■ MAILING (<i>Mailing Address</i>)</li> <li>■ OTHER (<i>Other Address</i>)</li> </ul> This value is required if any person mailing address information is included in the XML data file.
Person Mailing Address Street Line 1 Text <i>Example: 14 Main Rd.</i>	PersonMailingAddressDetail/MailingAddressStreetLine1Text	STRING	Y	100	MAILING_ADDRESS.LINE_1	This value is required if any person mailing address information is included in the XML data file.
Person Mailing Address Street Line 2 Text <i>Example: Suite 4</i>	PersonMailingAddressDetail/MailingAddressStreetLine2Text	STRING	N	100	MAILING_ADDRESS.LINE_2	
Person Mailing Address Street Line 3 Text <i>Example: Building 12</i>	PersonMailingAddressDetail/MailingAddressStreetLine3Text	STRING	N	100	MAILING_ADDRESS.LINE_3	
Person Mailing Address City Text <i>Example: Augusta</i>	PersonMailingAddressDetail/MailingAddressCityName	STRING	Y	50	MAILING_ADDRESS.CITY	This value is required if any person mailing address information is included in the XML data file.



Data Element	XML Tag Name	XML Data Type	Req'd (Y/N)	Length	Access Table Mapping	Comment
Person Mailing Address State Code <i>Example: ME</i>	PersonMailingAddressDetail/StateCode	STRING	Y	2	MAILING_ADDRESS.STATE_POSTAL_CODE	This value is required if any person mailing address information is included in the XML data file. This value must be a valid 2-character State Postal Code.
Person Mailing Address Zip Code <i>Example: 04333</i>	PersonMailingAddressDetail/AddressPostalCode	STRING	Y	12	MAILING_ADDRESS.ZIP_CODE	This value is required if any person mailing address information is included in the XML data file. This value must be in one of the following numeric formats: <ul style="list-style-type: none"> <li>■ #####</li> </ul> or <ul style="list-style-type: none"> <li>■ #####-####</li> </ul>
Person Mailing Address Effective Date <i>Example: 2003-01-01T00:00:00</i>	PersonMailingAddressDetail/MailingAddressEffectiveDate	DATE	Y		MAILING_ADDRESS.EFFECTIVE_DATE	This value is required if any person mailing address information is included in the XML data file. The date should be entered in the XML file in the following format: YYYY-MM-DDTHH:MI:SS This value should be set to the date on which the mailing address information became effective or will become effective. Please see Section 3.2 Use of Effective Date and Status Indicator Data Elements for more information.
Person Mailing Address Status Indicator <i>Example: ACTIVE</i>	PersonMailingAddressDetail/MailingAddressStatusIndicator	STRING	Y	8	MAILING_ADDRESS.STATUS	This value is required if any person mailing address information is included in the XML data file. This value must be set to "ACTIVE" or "INACTIVE". Please see Section 3.2 Use of Effective Date and Status Indicator Data Elements for more information.
Person Electronic Address Type Code <i>Example: EMAIL</i>	PersonElectronicAddressDetail/ElectronicAddressTypeCode	STRING	Y	12	ELECTRONIC_ADDRESS.ELECTRONIC_ADDRESS_CODE	This value must be set to one of the following: <ul style="list-style-type: none"> <li>■ EMAIL (<i>E-mail</i>)</li> <li>■ URL (<i>URL</i>)</li> <li>■ OTHER (<i>Other</i>)</li> </ul> This value is required if any person electronic address information is included in the XML data file.
Person Electronic Address Text <i>Example: Smith.Bob@maine.gov</i>	PersonElectronicAddressDetail/ElectronicAddressText	STRING	Y	255	ELECTRONIC_ADDRESS.ADDRESS	This value is required if any person electronic address information is included in the XML data file.

Data Element	XML Tag Name	XML Data Type	Req'd (Y/N)	Length	Access Table Mapping	Comment
Person Electronic Address Effective Date  <i>Example:</i> 2003-01-01T00:00:00	PersonElectronicAddressDetail/ElectronicAddressEffectiveDate	DATE	Y		ELECTRONIC_ADDRESS.EFFECTIVE_DATE	This value is required if any person electronic address information is included in the XML data file.  The date should be entered in the XML file in the following format: YYYY-MM-DDTHH:MI:SS  This value should be set to the date on which the electronic address information became effective or will become effective.  Please see Section 3.2 Use of Effective Date and Status Indicator Data Elements for more information.
Person Electronic Address Status Indicator  <i>Example:</i> ACTIVE	PersonElectronicAddressDetail/ElectronicAddressStatusIndicator	STRING	Y	8	ELECTRONIC_ADDRESS.STATUS	This value is required if any person electronic address information is included in the XML data file.  This value must be set to "ACTIVE" or "INACTIVE".  Please see Section 3.2 Use of Effective Date and Status Indicator Data Elements for more information.
Person Telephone Type Code  <i>Example:</i> CELL	PersonTelephoneDetail/TelephoneTypeCode	STRING	Y	12	TELEPHONE.TELEPHONE_TYPE_CODE	This value must be set to one of the following: <ul style="list-style-type: none"><li>■ FAX (<i>Fax</i>)</li><li>■ VOICE (<i>Voice</i>)</li><li>■ PAGER (<i>Pager</i>)</li><li>■ CELL (<i>Cellular/Mobile</i>)</li><li>■ OTHER (<i>Other</i>)</li></ul> This value is required if any person telephone information is included in the XML data file.
Person Telephone Number  <i>Example:</i> 207-287-1111	PersonTelephoneDetail/TelephoneNumberText	STRING	Y	12	TELEPHONE.TELEPHONE_NUMBER	This value is required if any person telephone information is included in the XML data file.  This value must be in the following alphanumeric format: <ul style="list-style-type: none"><li>■ XXX-XXX-XXXX</li></ul>

---

Data Element	XML Tag Name	XML Data Type	Req'd (Y/N)	Length	Access Table Mapping	Comment
Person Telephone Effective Date <i>Example:</i> 2003-01-01T00:00:00	PersonTelephoneDetail/EffectiveDate	DATE	Y		TELEPHONE.EFFECTIVE_DATE	<p>This value is required if any person telephone information is included in the XML data file.</p> <p>The date should be entered in the XML file in the following format: YYYY-MM-DDTHH:MI:SS</p> <p>This value should be set to the date on which the telephone information became effective or will become effective.</p> <p>Please see Section 3.2 Use of Effective Date and Status Indicator Data Elements for more information.</p>
Person Telephone Status Indicator <i>Example:</i> ACTIVE	PersonTelephoneDetail/StatusIndicator	STRING	Y	8	TELEPHONE.STATUS	<p>This value is required if any person telephone information is included in the XML data file.</p> <p>This value must be set to "ACTIVE" or "INACTIVE".</p> <p>Please see Section 3.2 Use of Effective Date and Status Indicator Data Elements for more information.</p>

---

### 3.1.3 Beach Information

The Beach Information section of the XML submission contains data related to the beaches overseen by the National Beach Program, such as beach name, beach description, state code, and county code. These data elements will be included in the XML file when beach information needs to be added or updated in the PRAWN database.

All XML elements in this section are located in the following position on the XML element hierarchy—“BeachDataSubmission/BeachDetail”.

Data Element	XML Tag Name	XML Data Type	Req'd (Y/N)	Length	Access Table Mapping	Comment
Beach Identifier <i>Example: ME234898</i>	BeachIdentifier	STRING	Y	8	BEACH.ID, BEACH_ACTIVITY.FK_BEACH_ID, BEACH_PROCEDURE_ASSIGN.FK_BEACH_ID, BEACH_PERSON_ROLE_ASSIGN.FK_BEACH_ID, BEACH_ORGANIZATION_ROLE_ASSIGN.FK_BEACH_ID, BEACH_LATITUDE_LONGITUDE_COORDINATE.FK_BEACH_ID	EPA maintains a list of valid Beach Identifiers for all beaches that are stored in the PRAWN database. Each new identifier must be registered with EPA before it can be submitted. These identifiers must be unique, as they will be used to update beach-level data.  *Send request for new Beach ID to <a href="mailto:ebeaches@cgifederal.com">ebeaches@cgifederal.com</a>
Beach Name <i>Example: Sandy Beach Point</i>	BeachNameDetail/ProgramInterestName	STRING	Y	60	BEACH.NAME	This value is required if any beach name information is included in the XML data file.
Beach Description Text <i>Example: Rocky, big waves, no pollution</i>	BeachNameDetail/ProgramInterestDescriptionText	STRING	Y	255	BEACH.DESCRPTION	This value is required if any beach name information is included in the XML data file.
Beach Comment Text <i>Example: A nice place to surf</i>	BeachNameDetail/ProgramInterestCommentText	STRING	N	255	BEACH.COMMENT	This is an optional field that can be used to store other information about the particular beach that is not included in an official description.
Beach State Code <i>Example: ME</i>	BeachNameDetail/ProgramInterestStateCode	STRING	Y	2	BEACH.STATE_POSTAL_CODE	This value is required if any beach name information is included in the XML data file.  This value must be a valid 2-character State Postal Code.

Data Element	XML Tag Name	XML Data Type	Req'd (Y/N)	Length	Access Table Mapping	Comment
Beach FIPS County Code <i>Example:</i> 23001	BeachNameDetail/ ProgramInterestFI PSCountyCode	STRING	Y	5	BEACH.FIPS_COUNTY	<p>This value is required if any beach name information is included in the XML data file.</p> <p>This value must be a valid 5 digit code representing a county, as assigned by the Federal Information Processing Standards Publications (FIPS). The first two digits represent the state, while the last three digits represent the specific county.</p> <p>FIPS county codes can be found at <a href="http://www.itl.nist.gov/fipspubs/codes/states.htm">http://www.itl.nist.gov/fipspubs/codes/states.htm</a></p>
Water Body Name Code <i>Example:</i> ATLANTIC	BeachNameDetail/ WaterBodyNameCode	STRING	N	12	BEACH.WATERBODY_NAME	<p>This value can be chosen from a list in Appendix D.</p> <p>This value is optional for all states except those on the Great Lakes.</p>
Water Body Type Code <i>Example:</i> OPEN_COAST T	BeachNameDetail/ WaterBodyTypeCode	STRING	N	12	BEACH.WATERBODY_TYPE	<p>If Water Body Name (above) is NOT assigned to INLAND, this value must be set to one of the following:</p> <ul style="list-style-type: none"> <li>■ OPEN_COAST (Open Coast)</li> <li>■ SND_BY_INLT (Sound, Bay, or Inlet)</li> </ul> <p>If Waterbody Name (above) IS assigned to INLAND, this value must be set to one of the following:</p> <ul style="list-style-type: none"> <li>■ STILL_WATER (Still Water)</li> <li>■ FLOW_WATER (Flowing Water)</li> </ul> <p>This value is optional for all states except those on the Great Lakes.</p>
Beach Accessibility Type <i>Example:</i> PUB_PRV_ACC C	BeachNameDetail/ BeachAccessibilityDetail/ BeachAccessibilityType	STRING	Y	12	BEACH.ACCESS_TYPE	<p>This value is required if any beach name information is included in the XML data file.</p> <p>The value must be set to one of the following:</p> <ul style="list-style-type: none"> <li>■ PUB_PUB_ACC (<i>Public Beach with Public Access</i>)</li> <li>■ PRV_PRV_ACC (<i>Private Beach with Private Access</i>)</li> <li>■ PUB_PRV_ACC (<i>Public Beach with Private Access</i>)</li> <li>■ PRV_PUB_ACC (<i>Private Beach with Public Access</i>)</li> </ul>

---

Data Element	XML Tag Name	XML Data Type	Req'd (Y/N)	Length	Access Table Mapping	Comment
Beach Accessibility Comment <i>Example: Public Property at the end of a road.</i>	BeachNameDetail/BeachAccessibilityDetail/BeachAccessibilityComment	STRING	N	255	BEACH.ACCESS_COMMENT	This is an optional field that can be used to store other information about the beach access that is not included in an official description.

---

### 3.1.4 Beach Attribute Information

The beach attribute section of the XML submission contains data related to beach information that may change over time, such as beach extent (length), swim season length, and monitoring frequency.

States should submit one ‘Beach Attribute Detail’ section each year for each beach.

All XML elements in this section are located in the following position on the XML element hierarchy—“BeachDataSubmission/BeachDetail/BeachAttributeDetail/”.

Data Element	XML Tag Name	XML Data Type	Req'd (Y/N)	Length	Access Table Mapping	Comment
Attribute Effective Year <i>Example: 2006</i>	AttributeEffectiveYear	STRING	Y	4	BEACH_ATTRIBUTE.EFFECTIVE_YEAR	This value is required if any beach attribute information is included in the XML data file.  Attribute Effective Year is appended to each of the beach extent, swim season, and monitoring frequency records in PRAWN to distinguish the change over time.  This value must be updated every year, even if the subsequent attribute information does not change, in order to verify the correct information for a beach.
Beach Extent Length Measure <i>Example: 5</i>	BeachExtentDetail/ExtentLengthMeasure	NUMBER	Y	14	BEACH_ATTRIBUTE.EXTENT_LENGTH	This value is required if any beach name information is included in the XML data file.  This value is the numeric equivalent of the length of a beach, along with the units of measure below.
Beach Extent Length Unit of Measure <i>Example: MI</i>	BeachExtentDetail/ExtentUnitOfMeasureCode	STRING	Y	12	BEACH_ATTRIBUTE.EXTENT_UNITS	This value must be set to one of the following: <ul style="list-style-type: none"> <li>■ MI (Miles)</li> <li>■ FT (Feet)</li> <li>■ YDS (Yards)</li> <li>■ M (Meters)</li> <li>■ KM (Kilometers)</li> </ul> This value is required if any beach name information is included in the XML data file.

Data Element	XML Tag Name	XML Data Type	Req'd (Y/N)	Length	Access Table Mapping	Comment
Swim Season Start Date <i>Example: 1/1/2007</i>	BeachSwimSeasonLengthDetail/SwimSeasonStartDate	DATE	Y	n/a	BEACH_ATTRIBUTE.SWIM_SEASON_START_DATE	<p>Either the combination of Swim Season Start Date and Swim Season End or the combination of Beach Season Length and Beach Season Unit of Measure are required if any beach name information is included in the XML data file. The combination of Swim Season Start Date and Swim Season End Date is preferred. If both are sets of information are included, Swim Season Start Date and Swim Season End Date will be used.</p> <p>This value is the date the beach swim season starts for the year.</p>
Swim Season End Date <i>Example: 12/31/2007</i>	BeachSwimSeasonLengthDetail/SwimSeasonEndDate	DATE	Y	n/a	BEACH_ATTRIBUTE.SWIM_SEASON_END_DATE	<p>Either the combination of Swim Season Start Date and Swim Season End or the combination of Beach Season Length and Beach Season Unit of Measure are required if any beach name information is included in the XML data file. The combination of Swim Season Start Date and Swim Season End Date is preferred. If both are sets of information are included, Swim Season Start Date and Swim Season End Date will be used.</p> <p>This value is the date the beach swim season ends for the year.</p>
Beach Season Length <i>Example: 150</i>	BeachSwimSeasonLengthDetail/SwimSeasonLengthMeasure	NUMBER	Y	14	BEACH_ATTRIBUTE.SWIM_SEASON_LENGTH	<p>Either the combination of Swim Season Start Date and Swim Season End or the combination of Beach Season Length and Beach Season Unit of Measure are required if any beach name information is included in the XML data file. The combination of Swim Season Start Date and Swim Season End Date is preferred. If both are sets of information are included, Swim Season Start Date and Swim Season End Date will be used.</p> <p>This value is the numeric equivalent of the amount of time in a swim season, along with the units of measure below.</p>



Data Element	XML Tag Name	XML Data Type	Req'd (Y/N)	Length	Access Table Mapping	Comment
Beach Season Unit of Measure <i>Example: DAYS</i>	BeachSwimSeasonLengthDetail/SwimSeasonUnitOfMeasureCode	STRING	Y	12	BEACH_ATTRIBUTE.SWIM_SEASON_UNITS	<p>This value must be set to one of the following:</p> <ul style="list-style-type: none"> <li>■ DAYS (<i>Days</i>)</li> <li>■ WEEKS (<i>Weeks</i>)</li> <li>■ MONTHS (<i>Months</i>)</li> </ul> <p>Either the combination of Swim Season Start Date and Swim Season End or the combination of Beach Season Length and Beach Season Unit of Measure are required if any beach name information is included in the XML data file. The combination of Swim Season Start Date and Swim Season End Date is preferred. If both are sets of information are included, Swim Season Start Date and Swim Season End Date will be used.</p>
Swim Season Monitoring Frequency <i>Example: 10</i>	MonitoringFrequencyDetail/SwimSeasonFrequencyMeasure	NUMBER	Y	14	BEACH_ATTRIBUTE.SWIM_MONITOR_FREQ	<p>This value is required if any beach attribute information is included in the XML data file.</p> <p>This value is the numeric equivalent of the frequency of monitoring performed during the designated Swim Season, as defined in the previous tags. The Swim Season Monitoring Frequency corresponds to the units of measure below.</p> <p>If monitoring is not performed on the beach during the swim season, please enter a 0 (zero) for this value.</p>
Off Season Monitoring Frequency <i>Example: 2</i>	MonitoringFrequencyDetail/OffSeasonFrequencyMeasure	NUMBER	Y	14	BEACH_ATTRIBUTE.OFF_MONITOR_FREQ	<p>This value is required if any beach attribute information is included in the XML data file.</p> <p>This value is the numeric equivalent of the frequency of monitoring performed outside of the designated Swim Season, as defined in the previous tags. The Off Season Monitoring Frequency corresponds to the units of measure below.</p> <p>If monitoring is not performed on the beach during the off season, please enter a 0 (zero) for this value.</p>

---

Data Element	XML Tag Name	XML Data Type	Req'd (Y/N)	Length	Access Table Mapping	Comment
Monitoring Frequency Unit of Measure <i>Example:</i> <i>PER_WEEK</i>	MonitoringFrequencyDetail/MonitoringFrequencyUnitOfMeasureCode	STRING	Y	12	BEACH_ATTRIBUTE.MONITOR_FREQ_UNITS	<p>This value must be set to one of the following:</p> <ul style="list-style-type: none"> <li>■ PER_DAY (<i>Per Day</i>)</li> <li>■ PER_WEEK (<i>Per Week</i>)</li> <li>■ PER_MONTH (<i>Per Month</i>)</li> <li>■ PER_YEAR (<i>Per Year</i>)</li> </ul> <p>This value is required if any beach attribute information is included in the XML data file.</p> <p>This value corresponds to both the Swim Season and Off Season Monitoring Frequencies. For example, if the Swim Season Monitoring Frequency Measure is 10, and the Units are PER_WEEK, the frequency reads "The beach is monitored 10 times per week during the swim season."</p>

---

Data Element	XML Tag Name	XML Data Type	Req'd (Y/N)	Length	Access Table Mapping	Comment
Monitored Irregularly Indicator <i>Example: Y</i>	MonitoredIrregularly	BOOLEAN	Y	1	BEACH_ATTRIBUTE.MONITORED_IRREGULARLY	This value is required if any beach attribute information is included in the XML data file.  This should be "Y" if the beach is monitored irregularly and "N" otherwise.
Monitored Irregularly Comment	MonitoredIrregularlyComment	Text	N	255	BEACH_ATTRIBUTE.MONITORED_IRREGULARLY_COMMENT	Any comments the about the regularity of the monitoring.
Pollutions Sources Indicator <i>Example: Y</i>	NoPollutionSourcesIndicator	BOOLEAN	Y	1	POLLUTION_SOURCES	This should be "Y" if there are any possible pollution sources for the beach. This should be "N" if pollution sources were investigated and none were found.  Note, see Appendix G for more information on populating data for pollution sources.
Pollutions Sources Investigated Indicator <i>Example: Y</i>	PollutionsSourcesUninvestigatedIndicator	BOOLEAN	Y	1	POLLUTION_SOURCES_INVESTIGATED	This should be "Y" if the beach pollution sources have been investigated and "N" otherwise.  Note, see Appendix G for more information on populating data for pollution sources.

Data Element	XML Tag Name	XML Data Type	Req'd (Y/N)	Length	Access Table Mapping	Comment
Beach Pollution Source Code <i>Example:</i> SEWER_LINE	BeachPollutionSourceDetail/BeachPollutionSourceCode	STRING	N	12	BEACH_POLLUTION.POLLUTION_SOURCE	<p>This value must be set to one of the following:</p> <ul style="list-style-type: none"> <li>▪ AGRICULTURAL (<i>Agricultural Runoff</i>)</li> <li>▪ BOAT (<i>Boat Discharge</i>)</li> <li>▪ CAFO (<i>Concentrated Animal Feeding Operation</i>)</li> <li>▪ CSO (<i>Combined Sewer Overflow</i>)</li> <li>▪ POTW (<i>Publicly-Owned Treatment Works</i>)</li> <li>▪ RUNOFF (<i>Non-storm Related/Urban/Dryweather runoff</i>)</li> <li>▪ SEPTIC (<i>Septic System Leakage</i>)</li> <li>▪ SEWER_LINE (<i>Sewer Line Leak/Break/Blockage</i>)</li> <li>▪ SSO (<i>Sanitary Sewer Overflow</i>)</li> <li>▪ STORM (<i>Storm Related/Wet-Weather Runoff</i>)</li> <li>▪ WILDLIFE (<i>Wildlife</i>)</li> <li>▪ UNKNOWN (<i>Unknown</i>)</li> <li>▪ OTHER (<i>Other-Specify in Description Field</i>)</li> </ul> <p>This value is designed to allow states to store pollution sources impacting a given beach. These may include "possible" sources, identified by a citable study or attributed to by a credible person or entity; even if not confirmed to a level suitable for use in a court of law.</p> <p>Additionally, note that submitting a beach with no potential pollution sources is identical to saying that no pollution sources are known to impact that beach.</p>
Beach Pollution Source Description	BeachPollutionSourceDetail/BeachPollutionSourceDescription	STRING	N	255	BEACH_POLLUTION.POLLUTION_COMMENT	<p>This is an optional field that can be used to store other information about the beach pollution source that is not included in an official description.</p>

---

Data Element	XML Tag Name	XML Data Type	Req'd (Y/N)	Length	Access Table Mapping	Comment
Beach Tier Ranking <i>Example: 2</i>	BeachTierRanking	NUMBER (0-9)	Y	1	BEACH_ATTRIBUTE.BEACH_TIER	<p>This value is required if any beach attribute information is included in the XML data file.</p> <p>The ranking system for this value is set by individual states, so the ranges may differ (e.g., State A may have tiers 1 and 2, while State B may have tiers 1, 2, and 3) States with no tier system should enter a value of '1' for all beaches.</p>
Beach Act Beach Indicator <i>Example: Y</i>	BeachActBeachIndicator	BOOLEAN	Y	1	BEACH_ATTRIBUTE.BEACH_ACT_BEACH	<p>This value is required if any beach attribute information is included in the XML data file.</p> <p>This should be "Y" if the beach qualifies as a BEACH Act beach and "N" otherwise.</p>

---

### 3.1.5 Beach Activity Information

The beach activity section of the XML submission contains data related to beach advisories and closures, such as activity type code, activity name, activity description text, and activity reason. These data elements will be included in the XML file when activity or closure information needs to be added to the PRAWN database. Beach activity information can only be added to the PRAWN database; it cannot be updated. Since activities require a start and stop date, only completed activities should be submitted.

States should submit one 'Beach Activity Detail' section per any one of the Activity Type Codes. Multiple 'Beach Activity Detail' sections can appear under one 'Beach Detail' section.

All XML elements in this section are located in the following position on the XML element hierarchy—"BeachDataSubmission/BeachDetail/BeachActivityDetail/".

Data Element	XML Tag Name	XML Data Type	Req'd (Y/N)	Length	Access Table Mapping	Comment
Activity Type Code <i>Example:</i> CLOSURE	ActivityTypeCode	STRING	Y	12	BEACH_ACTIVITY.ACTIVITY_CODE	<p>This value must be set to one of the following:</p> <ul style="list-style-type: none"> <li>■ CONTAM_ADV (<i>Contamination Advisory</i>)</li> <li>■ CLOSURE (<i>Closure</i>)</li> <li>■ PERM_CLOSURE (<i>Permanent Closure</i>)</li> <li>■ RAIN_ADV (<i>Rain Advisory</i>)</li> </ul> <p>This value is required if any beach activity information is included in the XML data file.</p> <p>States should submit one 'Beach Activity Detail' section per any one of the above activities.</p> <p>Activity Type Code and Activity Name are related in so far as the Activity Name can be used to keep track of the various activity types by assigning a local name to the various activities. There is not an Identifier in this portion of the data submission to aid in this endeavor.</p>
Activity Name <i>Example:</i> Closure 34	ActivityName	STRING	Y	60	BEACH_ACTIVITY.NAME	<p>This value is required if any beach activity information is included in the XML data file.</p> <p>Activity Type Code and Activity Name are related in so far as the Activity Name can be used to keep track of the various activity types by assigning a local name to the various activities. There is not an Identifier in this portion of the data submission to aid in this endeavor.</p>

Data Element	XML Tag Name	XML Data Type	Req'd (Y/N)	Length	Access Table Mapping	Comment
Activity Actual Start Date <i>Example:</i> 2002-04-12T02:00:00	ActivityActualStartDate	DATE	Y		BEACH_ACTIVITY.ACTUAL_START_DATE	This value is required if any beach activity information is included in the XML data file.  The date should be entered in the XML file in the following format: YYYY-MM-DDTHH:MI:SS
Activity Actual Stop Date <i>Example:</i> 2002-04-16T06:30:00	ActivityActualStopDate	DATE	Y		BEACH_ACTIVITY.ACTUAL_STOP_DATE	This value is required if any beach activity information is included in the XML data file.  The date should be entered in the XML file in the following format: YYYY-MM-DDTHH:MI:SS
Activity Reason Type <i>Example:</i> ELEV_BACT	ActivityReasonDetail/ActivityReasonType	STRING	Y	60	BEACH_ACTIVITY_REASON.TYPE (BEACH_ACTIVITY_REASON.CLASS = 'REASON')	This value must be set to one of the following: <ul style="list-style-type: none"> <li>■ ELEV_BACT (<i>Monitoring that revealed elevated bacteria levels</i>)</li> <li>■ RAINFALL (<i>Preemptive-Rainfall</i>)</li> <li>■ SEWAGE (<i>Preemptive-Sewage discharge or spill</i>)</li> <li>■ CHEM_OIL (<i>Preemptive-Chemical or oil discharge or spill</i>)</li> <li>■ MODEL (<i>Model prediction</i>)</li> <li>■ POLICY (<i>Policy dictates action</i>)</li> <li>■ OTHER (<i>Other-Please specify in the Description field</i>)</li> </ul> <p>This value is required only if beach activity information AND beach activity reason information is included in the XML data file.</p> <p>The Beach Activity Reason Type field is used to supply information regarding the reason for the activity denoted in the Activity Type Code field.</p> <p>Any number of Reason Detail sections may be submitted (consecutively in the XML file) to associate many reasons to a single activity.</p> <p>Note that activities with Type 'ELEV_BACT' must submit at least one Monitoring Station Identifier.</p>

Data Element	XML Tag Name	XML Data Type	Req'd (Y/N)	Length	Access Table Mapping	Comment
Activity Reason Description Text <i>Example: Exceeded Water Quality Standards</i>	ActivityReasonDetail/ActivityReasonDescriptionText	STRING	N	255	BEACH_ACTIVITY_REASON.DESCRPTION (BEACH_ACTIVITY_REASON.CLASS = 'REASON')	The Beach Activity Reason Description field is used to supply additional information regarding the reason for the activity denoted in the Activity Type Code field.
Activity Source Type <i>Example: CSO</i>	ActivitySourceDetail/ActivitySourceType	STRING	Y	60	BEACH_ACTIVITY_REASON.TYPE (BEACH_ACTIVITY_REASON.CLASS = 'SOURCE')	<p>This value must be set to one of the following:</p> <ul style="list-style-type: none"> <li>▪ AGRICULTURAL (<i>Agricultural Runoff</i>)</li> <li>▪ BOAT (<i>Boat Discharge</i>)</li> <li>▪ CAFO (<i>Concentrated Animal Feeding Operation</i>)</li> <li>▪ CSO (<i>Combined Sewer Overflow</i>)</li> <li>▪ POTW (<i>Publicly-Owned Treatment Works</i>)</li> <li>▪ RUNOFF (<i>Non-storm Related/Urban/Dryweather runoff</i>)</li> <li>▪ SEPTIC (<i>Septic System Leakage</i>)</li> <li>▪ SEWER_LINE (<i>Sewer Line Leak/Break/Blockage</i>)</li> <li>▪ SSO (<i>Sanitary Sewer Overflow</i>)</li> <li>▪ STORM (<i>Storm Related/Wet-Weather Runoff</i>)</li> <li>▪ WILDLIFE (<i>Wildlife</i>)</li> <li>▪ UNKNOWN (<i>Unknown</i>)</li> <li>▪ OTHER (<i>Other-Specify in Description Field</i>)</li> </ul> <p>This value is required only if beach activity information AND beach activity source information is included in the XML data file.</p> <p>The Beach Activity Source Type field is used to supply information regarding the source of the activity denoted in the Activity Type Code field.</p>
Activity Source Description Text <i>Example: Visible from CSO</i>	ActivitySourceDetail/ActivitySourceDescriptionText	STRING	N	255	BEACH_ACTIVITY_REASON.DESCRPTION (BEACH_ACTIVITY_REASON.CLASS = 'SOURCE')	The Beach Activity Source Type field is used to supply additional information regarding the source of the activity denoted in the Activity Type Code field.



Data Element	XML Tag Name	XML Data Type	Req'd (Y/N)	Length	Access Table Mapping	Comment
Activity Indicator Type <i>Example: PREEMPT</i>	ActivityIndicatorDetail/ActivityIndicatorType	STRING	Y	60	BEACH_ACTIVITY_REASON.TYPE (BEACH_ACTIVITY_REASON.CLASS = 'INDICATOR')	<p>This value must be set to one of the following:</p> <ul style="list-style-type: none"> <li>■ PREEMPT (<i>Preemptive</i>)</li> <li>■ ENTERO (<i>Enterococci</i>)</li> <li>■ TOTAL_COL (<i>Total Coliform</i>)</li> <li>■ FECAL_COL (<i>Fecal Coliform</i>)</li> <li>■ ECOLI (<i>E. coli</i>)</li> <li>■ RATIO (<i>Total/Fecal Ratio</i>)</li> <li>■ OTHER (<i>Other-Please specify in the Description field</i>)</li> </ul> <p>This value is required only if beach activity information AND beach activity indicator information is included in the XML data file.</p> <p>The Beach Activity Indicator Type field is used to supply information regarding the indicator for the activity denoted in the Activity Type Code field.</p>
Activity Indicator Description Text <i>Example: To avoid more actions</i>	ActivityIndicatorDetail/ActivityIndicatorDescriptionText	STRING	N	255	BEACH_ACTIVITY_REASON.DESCRPTION (BEACH_ACTIVITY_REASON.CLASS = 'INDICATOR')	<p>This value is required only if beach activity information AND beach activity indicator information is included in the XML data file.</p>
Activity Monitoring Station ID <i>Example: 21MEBCH Station1</i>	ActivityMonitoringStationIdentifier	STRING	N	65	BEACH_ACTIVITY_STATION.STATION_ID	<p>This value corresponds to the combination of a valid, pre-registered STORET organization ID and the valid, pre-registered STORET station ID that impacted the activity.</p> <p>The two IDs must be joined together with a "pipe" (" ") character (e.g., 'OrgID StationID').</p> <p>Any number of Monitoring Station IDs may be submitted (consecutively in the XML file) to associate many stations to a single activity.</p> <p>This value is required if the Activity Reason Type is 'ELEV_BACT'.</p>
Activity Description Text <i>Example: The lifeguards closed the beach</i>	ActivityDescriptionText	STRING	N	255	BEACH_ACTIVITY.DESCRPTION	<p>This is an optional field that can be used to describe anything about the activity itself. An example might be, "The lifeguards closed the beach."</p>

Data Element	XML Tag Name	XML Data Type	Req'd (Y/N)	Length	Access Table Mapping	Comment
Activity Comment Text <i>Example: The police were not present</i>	ActivityCommentText	STRING	N	255	BEACH_ACTIVITY.COMMENT	This is an optional field that can be used to store other information about the particular activity. An example might be, "The police were not present."
Activity Start Measure <i>Example: 2</i>	ActivityExtentDetail/ActivityExtentStartMeasure	NUMERIC	N	14	BEACH_ACTIVITY.EXTENT_START_MEASURE	This value is the numeric equivalent of the location or mile marker where the length of affected beach begins. The activity extent length (below) is added to the activity start measure to understand the exact extent of beach that was affected by the activity.  For example, a start measure of 2 with an extent length of 5 and a unit of measure code of mi means the activity affected the beach from mile marker 2 to mile marker 7.
Activity Extent Length Measure <i>Example: 5</i>	ActivityExtentDetail/ActivityExtentLengthMeasure	NUMERIC	Y	14	BEACH_ACTIVITY.EXTENT_LENGTH	This value is required only if any beach activity information AND any beach activity extent information is included in the XML data file.  See Activity Start Measure (above) for an explanation of the use of this value.
Activity Unit of Measure Code <i>Example: MI</i>	ActivityExtentDetail/ActivityUnitOfMeasureCode	STRING	Y	12	BEACH_ACTIVITY.EXTENT_UNIT_OF_MEASURE	This value must be set to one of the following: <ul style="list-style-type: none"> <li>■ MI (Miles)</li> <li>■ FT (Feet)</li> <li>■ YDS (Yards)</li> <li>■ M (Meters)</li> <li>■ KM (Kilometers)</li> </ul> This value is required only if any beach activity information AND any beach activity extent information is included in the XML data file.

---

### 3.1.6 Beach Role Information

---

The beach role section of the XML submission allows submitting states to provide data related to the Organization and/or Person performing roles for a given beach. This section includes data elements, such as beach role type code, organization identifier, and person identifier. These data elements will be included in the XML file when beach role information needs to be added or updated in the PRAWN database.

All XML elements in this section are located in the following position on the XML element hierarchy—“BeachDataSubmission/BeachDetail/BeachRoleDetail”.

---

Data Element	XML Tag Name	XML Data Type	Req'd (Y/N)	Length	Access Table Mapping	Comment
--------------	--------------	---------------	-------------	--------	----------------------	---------

---

Data Element	XML Tag Name	XML Data Type	Req'd (Y/N)	Length	Access Table Mapping	Comment
Beach Role Type Code <i>Example:</i> <i>LOCAL</i>	BeachRoleTypeCode	STRING	Y	12	BEACH_ORGANIZATION_ROLE_ASSIGN.ORG_ROLE_CODE, BEACH_PERSON_ROLE_ASSIGN.PERSON_ROLE_CODE	<p>People/organizations are assigned a role on a beach via the 'Beach Role Type Code' field.</p> <p>For beach/organization assignments, this value must be set to one of the following:</p> <ul style="list-style-type: none"> <li>■ LOCAL (<i>Lead Local Agency</i>)</li> <li>■ STATE (<i>Lead State Agency</i>)</li> <li>■ CONTRACTOR (<i>Contractor</i>)</li> <li>■ SUBCONTRACT (<i>Subcontractor</i>)</li> <li>■ RESPONDENT (<i>Respondent</i>)</li> <li>■ DETERM_AUTH (<i>Determination Authority</i>)</li> <li>■ ISSUAN_AUTH (<i>Issuance Authority</i>)</li> <li>■ REOPEN_AUTH (<i>Reopening Authority</i>)</li> <li>■ LAB (<i>Laboratory</i>)</li> <li>■ COLLECTOR (<i>Sample Collector</i>)</li> <li>■ ANALYZER (<i>Sample Analyzer</i>)</li> <li>■ OTHER (<i>Other</i>)</li> <li>■ UNKNOWN (<i>Unknown</i>)</li> </ul> <p>For beach/person assignments, this value must be set to one of the following:</p> <ul style="list-style-type: none"> <li>■ STATE (<i>Lead State Contact</i>)</li> <li>■ LOCAL (<i>Lead Local Contact</i>)</li> <li>■ COLLECTOR (<i>Sample Collector</i>)</li> <li>■ ANALYZER (<i>Sample Analyzer</i>)</li> <li>■ RESPONDENT (<i>Respondent</i>)</li> <li>■ TECHNICAL (<i>Technical Contact</i>)</li> <li>■ PUBLIC (<i>Public Contact</i>)</li> <li>■ DETERM_AUTH (<i>Determination Authority</i>)</li> <li>■ ISSUAN_AUTH (<i>Issuance Authority</i>)</li> <li>■ REOPEN_AUTH (<i>Reopening Authority</i>)</li> <li>■ INFO_TECH (<i>Information Technology Authority</i>)</li> </ul> <p>This value is required if any beach role information is included in the XML data file.</p>

Data Element	XML Tag Name	XML Data Type	Req'd (Y/N)	Length	Access Table Mapping	Comment
Beach Role Organization Identifier <i>Example:</i> 987654321098	BeachRoleOrganizationIdentifier	STRING	Y	12	BEACH_ORGANIZATION_ROLE_ASSIGN.FK_ORGANIZATION_ID, PERSON.FK_ORGANIZATION_ID	A beach is associated with an organization via this field. To do so, enter the Organization Identifier in the Beach Role Organization Identifier field.  This value must correspond to a valid Organization Identifier in the XML file or in the PRAWN database.
Beach Role Person Identifier <i>Example:</i> 123456789012	BeachRolePersonIdentifier	STRING	N	12	BEACH_PERSON_ROLE_ASSIGN.FK_PERSON_ID	A beach can be associated with a person via this field. To do so, enter the Person Identifier in the Beach Role Person Identifier field in addition to entering the Organization Identifier in the Beach Role Organization Identifier field.  The Beach Role Person Identifier must correspond to a valid Person Identifier in the XML file or in the PRAWN database.
Beach Role Effective Date <i>Example:</i> 2003-01-01T00:00:00	BeachRoleEffectiveDate	DATE	Y		BEACH_ORGANIZATION_ROLE_ASSIGN.EFFECTIVE_DATE, BEACH_PERSON_ROLE_ASSIGN.EFFECTIVE_DATE	This value is required if any beach role information is included in the XML data file.  The date should be entered in the XML file in the following format: YYYY-MM-DDTHH:MI:SS  This value should be set to the date on which the beach role information became effective or will become effective.  Please see Section 3.2 Use of Effective Date and Status Indicator Data Elements for more information.
Beach Role Status Indicator <i>Example:</i> ACTIVE	BeachRoleStatusIndicator	STRING	Y	8	BEACH_ORGANIZATION_ROLE_ASSIGN.STATUS, BEACH_PERSON_ROLE_ASSIGN.STATUS	This value is required if any beach role information is included in the XML data file.  This value must be set to "ACTIVE" or "INACTIVE".  Please see Section 3.2 Use of Effective Date and Status Indicator Data Elements for more information.

### 3.1.7 Beach Coordinate Information

The beach coordinate section of the XML submission allows submitting states to provide data related to the end points of a given beach. This section includes data elements, such as latitude measure, longitude measure, source map scale, horizontal collection method name, and horizontal coordinate reference system datum name. These data elements will be included in the XML file when beach coordinate information needs to be added or updated in the PRAWN database.

Data Element	XML Tag Name	XML Data Type	Req'd (Y/N)	Length	Access Table Mapping	Comment
Latitude Measure	LatitudeMeasure	NUMBER	Y	6-8	BEACH_LATITUDE_LONGITUDE_COORDINATES.START_LATITUDE BEACH_LATITUDE_LONGITUDE_COORDINATES.END_LATITUDE	The measure of the angular distance on a meridian north or south of the equator.  Signed Decimal Latitude with positive values north of the Equator.
<i>Example:</i> 34.141592						
Longitude Measure	LongitudeMeasure	NUMBER	Y	6-9	BEACH_LATITUDE_LONGITUDE_COORDINATES.START_LONGITUDE BEACH_LATITUDE_LONGITUDE_COORDINATES.END_LONGITUDE	The measure of the angular distance on a meridian east or west of the prime meridian.  Signed Decimal Longitude with negative values west of Greenwich.
<i>Example:</i> -74.141592						
Source Map Scale Numeric	SourceMapScaleNumeric	NUMBER	C	14	BEACH_LATITUDE_LONGITUDE_COORDINATES.SOURCE_MAP_SCALE	The number that represents the relative distance on the ground for one unit of measure on the map or photo.  This field is mandatory only when the Horizontal Collection Method Name used is INTERPOLATION MAP.
<i>Example:</i> 12500						
Horizontal Collection Method Name	HorizontalCollectionMethodName	STRING	Y	150	BEACH_LATITUDE_LONGITUDE_COORDINATES.REF_H_COLLECTION_METHOD_NAME	The name that identifies the method used to determine the latitude and longitude coordinates for a point on the earth.
<i>Example:</i> INTERPOLATION-MAP INTERPOLATION-SATELLITE GPS						

---

Horizontal Coordinate Reference System Datum Name	HorizontalCoordinateReferenceSystemDatumName	STRING	Y	6	BEACH_LATITUDE_LONGITUDE_COORDINATES.REF_H_REFERENCE_DATUM_NAME	The name that describes the system used in determining the latitude and longitude coordinates.
---	--	--------	---	---	---	--

*Example:*  
 NAD27  
 NAD83

Description	BeachCoordinateDescriptionText	STRING	N	255	BEACH_LATITUDE_LONGITUDE_COORDINATES.DESCRPTION	This is an optional field that can be used to store other information about the particular beach's coordinates.
-------------	--------------------------------	--------	---	-----	---	---

*Example:*  
 Short  
 Description.

### 3.1.8 Year Completion Indicators

The Year Completion Indicators section of the XML submission allows submitting states to notify the EPA when they have finished submissions for the year. This section includes data elements, such as Notification Data Complete Indicator, Monitoring Data Complete Indicator, and Location Data Complete Indicator. These data elements will be included in the XML file when states wish to notify that the EPA that they have finished submitting data for the year.

NOTE: To generate a submission with the Notification Access database with year completion information, you can now use the Custom XML Generation form. This includes end of year completion information with your normal xml submission. There are no tables to fill out to generate this submission.

All XML elements in this section are located in the following position on the XML element hierarchy—"BeachDataSubmission/YearCompletionIndicators/".

Data Element	XML Tag Name	XML Data Type	Req'd (Y/N)	Length	Access Table Mapping	Comment
Completion Year <i>Example: 2007</i>	CompletionYear	NUMBER	N	4	N/A	This value is required if any year completion data is included in the XML data file.  This value indicates what year the data has been submitted for.  This can be created using the End Of Year Submission Generation form.
Notification Data Completion Indicator <i>Example: Y</i>	NotificationDataCompletionIndicator	BOOLEAN	N	N/A	N/A	This value indicates whether or not the Notification data has all been submitted for the calendar year.  This can be created using the End Of Year Submission Generation form.
Monitoring Data Completion Indicator <i>Example: Y</i>	MonitoringDataCompletionIndicator	BOOLEAN	N	N/A	N/A	This value indicates whether or not the Monitoring data has all been submitted for the calendar year.  This can be created using the End Of Year Submission Generation form.
Location Data Completion Indicator <i>Example: Y</i>	LocationDataCompletionIndicator	BOOLEAN	N	N/A	N/A	This value indicates whether or not the Location data has all been submitted for the calendar year.  This can be created using the End Of Year Submission Generation form.



### 3.1.9 Beach Procedure Information

The beach procedure section of the XML submission contains data related to the procedures used by beaches for monitoring, notification, issuance, and reopening. This section includes data elements, such as procedure type code, procedure description text, and procedure identifier. These data elements will be included in the XML file when beach procedure information needs to be added or updated in the PRAWN database.

All XML elements in this section are located in the following position on the XML element hierarchy—“BeachDataSubmission/BeachDetail/BeachProcedureDetail”.

Data Element	XML Tag Name	XML Data Type	Req'd (Y/N)	Length	Access Table Mapping	Comment
Procedure Type Code <i>Example:</i> IA_RADIO	ProcedureTypeCode	STRING	Y	12	PROCEDURE.PROCEDURE_CODE	This value must be set to a valid procedure type code. See <b>Error! Reference source not found.</b> for a list of valid codes.  This value is required if any beach procedure information is included in the XML data file.
Procedure Description Text <i>Example:</i> Announce the advisory on the local radio station	ProcedureDescriptionText	STRING	Y	255	PROCEDURE.DESCRPTION	This value is required if any beach procedure information is included in the XML data file.
Procedure Identifier <i>Example:</i> 675849302019	ProcedureIdentifier	STRING	Y	12	PROCEDURE.ID	Submitting organizations will need to maintain a list of valid Procedure Identifiers for all procedures that are stored in the PRAWN database. These identifiers must be unique within each organization, as they will be used to update organization-level data. (For example, with an organization there can only be 1 procedure identified as “AB123”, but there could be another procedure identified as “AB123” in another organization.)
Procedure Beach Identifier <i>Example:</i> ME234898	ProcedureBeachIdentifier	STRING	Y	12	BEACH_PROCEDURE_ASIGN.FK_BEACH_ID	This value must correspond to EITHER a valid Beach Identifier and/or a valid Program Interest Identifier in the XML file or in the PRAWN database.  Any number of Procedure Beach Identifiers may be submitted (consecutively in the XML file) to associate many beaches and/or program interests to a single procedure.

---

### 3.1.10 Header Information

---

The header information section of the XML file contains information regarding the data submission, such as submission date, submitting user, and submitting agency. **These keys should not be included in the XML file submitted by the submitting agency.** Instead, once an XML file has been successfully submitted to CDX, these XML keys will be added to the file by the CDX web application.

All XML elements in this section are located in the following position on the XML element hierarchy—"BeachDataSubmission/HeaderDetail/".

Data Element	XML Tag Name	XML Data Type	Req'd (Y/N)	Length	Access Table Mapping	Comment
Submitting Agency Identifier <i>Example:</i> KYDEP	SubmittingAgencyIdentifier	STRING	Y	12		This key will be inserted into the file by the CDX web application. The list of valid Submitting Agency Identifiers will be maintained as part of the CDX registration process.
Submitting User Identifier <i>Example:</i> BSMITH	SubmittingUserIdentifier	STRING	Y	12		This key will be inserted into the file by the CDX web application. The list of valid Submitting User Identifiers will be maintained as part of the CDX registration process.
Submission Identifier <i>Example:</i> 111111111111	SubmissionIdentifier	STRING	Y	12		This key will be inserted into the file by the CDX web application. This value will uniquely identify each submission and will be generated by the CDX web application.
Submission Date <i>Example:</i> 2003-01-01T00:00:00	Submission Date	DATE	Y			This key will be inserted into the file by the CDX web application. The date should be entered in the XML file in the following format: YYYY-MM-DDTHH:MI:SS

### 3.2 Use of Effective Date and Status Indicator Data Elements

---

The Effective Date and Status Indicator data elements are used to set the effective dates in the PRAWN database for mailing addresses, electronic addresses, telephone numbers, beach/person roles, and beach/organization roles. For each of these types of data, the PRAWN database tracks the Start Date and Stop Date. For example, the database may track that a fax telephone number was valid starting on January 1, 2001. If this telephone number was updated and the new fax number was valid on July 1, 2001, a new record is added in the database with a Start Date of July 1, 2001 and the same date is added as the Stop Date for the previous telephone number.

---

To set this information correctly, the XML schema uses two data elements—Effective Date and Status Indicator—with mailing address, electronic address, telephone, beach/person role, and beach/organization role data. Furthermore, the user must specify the appropriate Type Code value (e.g., “FAX”, “VOICE”, etc. for telephone number) so that the correct address, telephone number, beach/person role, or beach/organization role is updated.

To update these types of data, these three data elements should be populated as follows:

- To update an address, electronic address, telephone number, beach/person role assignment, or beach/organization assignment, the Effective Date and Status Indicator fields should be set as follows:
  - Effective Date should be set to the date on which the new address, telephone number, or assignment will become valid.
  - Status Indicator should be set to “ACTIVE”.
  - Type Code should be set to the type of information to be updated. (For example, this might be set to “STATE” for BeachRoleTypeCode.)
  - This will update the Stop Date for the current data and will create a new record with the updated data and the associated Start Date.
- To indicate that an address, electronic address, telephone number, beach/person role assignment, or beach/organization assignment is no longer valid and there is no replacement data, the Effective Date and Status Indicator fields should be set as follows:
  - Effective Date should be set to the date on which the address, telephone number, or assignment will become invalid.
  - Status Indicator should be set to “INACTIVE”.
  - Type Code should be set to the type of information to be updated. (For example, this might be set to “SHIPPING” for MailingAddressTypeCode.)

This will update the Stop Date for the current data but will not create a new record, since there is no new data.

---

## 4 How to Decode the Error Messages

This chapter provides detailed information regarding the error messages that may be produced during data transfer. This chapter assumes that the XML submission has passed XML schema validation before being processed by the data loading software.

### 4.1 System Generated Error Messages

---

This section describes system generated error messages associated with the validation and loading of National Beach Program data to the PRAWN database. The following table details the specific error codes and messages that may be produced during data loading and provides a short description of each error and appropriate corrective actions. It should be noted that error messages will be followed by XML tag value(s) to describe the location in the XML document where the error occurred. For instance, the error message ‘OrganizationName is required for adding/editing an Organization’ would be followed by the text ‘[OrganizationIdentifier = X]’ where ‘X’ is the identifier for the Organization where the error occurred.

All errors encountered during the processing and loading of an XML data submission will be written to an Error Log File that can be sent to CDX and used for reporting feedback to data submitters. In addition to PRAWN system generated errors, Oracle specific error messages will also be written to this file (see Section **Error! Reference source not found.** for more information).

**Exhibit 4-1 PRAWN Error Messages**

Error Code	Error Message	Description/Corrective Action
BCH-0101	OrganizationIdentifier must be unique for adding an Organization to the PRAWN system. [OrganizationIdentifier = 'X']	All new Organization records must have a previously unused value for Organization Identifier in the PRAWN system. Confirm that you are using the assigned OrganizationIdentifier.
BCH-0102	OrganizationIdentifier not found in the PRAWN system. [OrganizationIdentifier = 'X']	You are attempting to edit a record that does not exist. Please confirm that you have entered the correct Organization Identifier for the record you are attempting to edit or change OrganizationTransactionType to add if you wish to create a new Organization record.
BCH-0103	OrganizationTypeCode is invalid. [OrganizationIdentifier = 'X'; OrganizationTypeCode = 'X']	A value unknown to the PRAWN system has been submitted for OrganizationTypeCode. Please see Chapter 3 for a list of valid values.
BCH-0201	PersonIdentifier must be unique within an Organization. [OrganizationIdentifier = 'X'; PersonIdentifier = 'X']	All new Person records must have a value for Person Identifier that is previously unused by the referenced Organization in the PRAWN system.
BCH-0202	PersonIdentifier not found within the specified Organization. [OrganizationIdentifier = 'X'; PersonIdentifier = 'X']	You are attempting to edit a record that does not exist within the specified Organization. Please confirm that you have entered the correct Person Identifier for the record you are attempting to edit or change PersonTransactionType to add if you wish to create a new Person record.

<b>Error Code</b>	<b>Error Message</b>	<b>Description/Corrective Action</b>
BCH-0301	MailingAddressTypeCode is invalid. [OrganizationIdentifier = 'X'; MailingAddressTypeCode = 'X']	A value unknown to the PRAWN system has been submitted for MailingAddressTypeCode. Please see Chapter 3 for a list of valid values.
BCH-0302	MailingAddressStateCode is invalid. [OrganizationIdentifier = 'X'; MailingAddressStateCode = 'X']	MailingAddressStateCode must be a valid 2-digit State Postal Code (such as CA for California). Confirm that you are using a valid state code.
BCH-0303	MailingAddressZipCode is invalid. [OrganizationIdentifier = 'X'; MailingAddressZipCode = 'X']	Provide a MailingAddressZipCode in one of the following numeric formats: ##### or #####-####
BCH-0401	ElectronicAddressTypeCode is invalid. [OrganizationIdentifier = 'X'; ElectronicAddressTypeCode = 'X']	A value unknown to the PRAWN system has been submitted for ElectronicAddressTypeCode. Please see Chapter 3 for a list of valid values.
BCH-0501	TelephoneNumber is invalid. [OrganizationIdentifier = 'X'; TelephoneNumber = 'X']	Provide a TelephoneNumber in one of the following alphanumeric formats: XXX-XXX-XXXX
BCH-0502	TelephoneTypeCode is invalid. [OrganizationIdentifier = 'X'; TelephoneTypeCode = 'X']	A value unknown to the PRAWN system has been submitted for TelephoneTypeCode. Please see Chapter 3 for a list of valid values.
BCH-0601	ProgramInterestStateCode is invalid. [BeachIdentifier = 'X'; ProgramInterestStateCode = 'X']	ProgramInterestStateCode must be a valid 2-digit State Postal Code (such as CA for California). Confirm that you are using a valid state code.
BCH-0602	BeachIdentifier must be unique for adding a Beach to the PRAWN system. [BeachIdentifier = 'X']	All new Beach records must have a previously unused value for Beach Identifier in the PRAWN system. Confirm that you are using the assigned 8-digit BeachIdentifier.
BCH-0603	BeachIdentifier registered but not previously submitted to the PRAWN system. [BeachIdentifier = 'X'; BeachNameTransactionTypeCode = 'X']	You are attempting to edit a record that does not exist. Please confirm that you have entered the correct Beach Identifier for the record you are attempting to edit or change Beach Transaction Type Code to add if you wish to create a new Beach record.
BCH-0604	BeachIdentifier not registered with EPA. [BeachIdentifier = 'X']	You are attempting to submit notification data for a beach with an identifier that has not been assigned by EPA. Contact your EPA beach coordinator for the appropriate beach identifier.
BCH-0605	ProgramInterestFIPSCountyCode is invalid. [BeachIdentifier = 'X'; ProgramInterestFIPSCountyCode = 'X']	ProgramInterestFIPSCountyCode must be valid 5-digit FIPS County Code. Confirm that you are using a valid code, and that it matches the two letter State code submitted as ProgramInterestStateCode.
BCH-0606	WaterBodyNameCode cannot be combined with WaterBodyTypeCode. [BeachIdentifier = 'X'; WaterBodyNameCode = 'X'; WaterBodyTypeCode = 'X']	The Waterbody Name Code submitted for the beach must correspond to an acceptable Waterbody Type Code. Please see Chapter 3 for acceptable matches (e.g., a Name of INLAND may only have a Type of STILL_WATER or FLOW_WATER).

<b>Error Code</b>	<b>Error Message</b>	<b>Description/Corrective Action</b>
BCH-0607	Beach Extent/Swim Season/Monitoring Frequencies already defined for the year on beach. [BeachIdentifier = 'X'; AttributeEffectiveYear = 'X']	The Beach Attribute information (Beach Extent/Swim Season/Monitoring Frequencies/Beach Tier/Pollution Source) you have submitted already exists for that particular beach, for that particular year. Please either revise the Attribute Effective Date to the appropriate year, or contact the EPA Beach program manager to ensure the proper information is stored in the PRAWN system.
BCH-0701	ActivityTypeCode is invalid. [BeachIdentifier = 'X'; ActivityName = 'X'; ActivityTypeCode = 'X']	A value unknown to the PRAWN system has been submitted for ActivityTypeCode. Please see Appendix B for a list of valid values.
BCH-0702	ActivityMonitoringStationIdentifier not found in the STORET system. [BeachIdentifier = 'X'; ActivityName = 'X'; ActivityMonitoringStationIdentifier = 'X']	You are attempting to submit a monitoring station ID that has not been registered with STORET. Check the validity of the Station ID and if valid, ensure it has been registered as a monitoring station in STORET. Contact your EPA beach coordinator for further information.
BCH-0703	Activities with elevated bacteria (ELEV_BACT) as reasons must have at least one valid STORET Station ID. [BeachIdentifier = 'X'; ActivityName = 'X']	You are attempting to report a notification activity based on elevated bacteria levels without submitting a valid STORET Station ID. Each activity with a Reason Type Code of 'ELEV_BACT' must have at least one Monitoring Station ID.
BCH-0704	Activity Reason/Source/Indicator Description must be included if Activity Reason/Source/Indicator Code is OTHER. [BeachIdentifier = 'X'; ActivityName = 'X']	You are attempting to submit either a Reason, a Source, or an Indicator for an activity labeled with type 'OTHER' without submitting a description for the Reason, Source, or Indicator.
BCH-0705	ActivityActualStartDate year does not match year of ActivityActualStopDate. [BeachIdentifier = 'X'; ActivityName = 'X'; ActivityActualStartDate = 'X'; ActivityActualStopDate = 'X']	You are attempting to submit an Activity that is spanning multiple years. Activities may only be submitted for one year at a time. Should an activity actually go on for more than one year, it is required that the initial activity end on December 31 <sup>st</sup> 11:59:59pm of the current year and a new activity start again on January 1 <sup>st</sup> 12:00:00am of the next year.
BCH-0706	ActivityActualStopDate occurs prior to ActivityActualStartDate. [BeachIdentifier = 'X'; ActivityName = 'X'; ActivityActualStartDate = 'X'; ActivityActualStopDate = 'X']	You are attempting to submit an Activity whose stop date occurred before it was started. Please correct the dates so the stop date is after the start date.
BCH-0801	BeachRoleTypeCode is invalid. [BeachIdentifier = 'X'; BeachRoleOrganizationIdentifier = 'X'; BeachRoleTypeCode = 'X']	A value unknown to the PRAWN system has been submitted for BeachRoleTypeCode. Please see Chapter 3 for a list of valid values.
BCH-0802	BeachRoleOrganizationIdentifier not found in the PRAWN system. [BeachIdentifier = 'X'; BeachRoleOrganizationIdentifier = 'X']	You are attempting to associate a role with an Organization that does not exist in the PRAWN system. Please confirm that you have entered the correct Organization Identifier and that the information for that Organization has been previously submitted and successfully processed by the PRAWN system.

Error Code	Error Message	Description/Corrective Action
BCH-0803	BeachRolePersonIdentifier not found in the PRAWN system. [BeachIdentifier = 'X'; BeachRoleOrganizationIdentifier = 'X'; BeachRolePersonIdentifier = 'X']	You are attempting to associate a role with a person that does not exist in the PRAWN system. Please confirm that you have entered the correct Person Identifier and that the information for that Person has been previously submitted and successfully processed by the PRAWN system.
BCH-0804	BeachRolePersonIdentifier cannot be assigned a role on a beach without a role assignment for the person's parent organization on the same beach. [BeachIdentifier = 'X'; BeachRoleOrganizationIdentifier = 'X'; BeachRolePersonIdentifier = 'X']	You are attempting to associate a Person with a Beach without having associated that Person's Organization to the beach. Please check that the Organization Role Information precedes the Person Role Information in the XML file.
BCH-0901	ProcedureIdentifier must be unique for adding a Procedure to the PRAWN system. [ProcedureIdentifier = 'X']	All new Procedure records must have a value for Procedure Identifier that is previously unused by the referenced Organization in the PRAWN system.  To update an existing Procedure, including assigning more beaches to the Procedure, change the ProcedureTypeCode to 'EDIT'.
BCH-0902	ProcedureIdentifier not found in the PRAWN system. [ProcedureIdentifier = 'X']	You are attempting to edit a record that does not exist. Please confirm that you have entered the correct Procedure Identifier for the record you are attempting to edit or change ProcedureTransactionType to add if you wish to create a new Procedure record.
BCH-0903	ProcedureTypeCode is invalid. [ProcedureIdentifier = 'X'; ProcedureTypeCode = 'X']	A value unknown to the PRAWN system has been submitted for ProcedureTypeCode. Please see <b>Error! Reference source not found.</b> for a list of valid values.
BCH-0904	ProcedureBeachIdentifier not found in the PRAWN system. [ProcedureIdentifier = 'X'; ProcedureBeachIdentifier = 'X']	You are attempting to associate a procedure with a beach that does not exist in the PRAWN system. Please confirm that you have entered the correct Beach Identifier and that the information for that Beach has been previously submitted and successfully processed by the PRAWN system.

## 4.2 Common Causes of Error Messages

When troubleshooting an error log returned by the PRAWN system, please refer to the following chart for help with some of the most common errors (full-text error messages can be found in section **Error! Reference source not found.**). If the error is not resolved following the suggestions below, please contact [ebeaches@cgifederal.com](mailto:ebeaches@cgifederal.com).

## Exhibit 4-2 Common Error Messages

Error Code	Troubleshooting Tip	Page(s)
BCH-0101	Please check the value of the OrganizationNameTransactionTypeCode tag (ORGANIZATION.TRANSACTION in the Notification Access Database). Generally, this error occurs if the related OrganizationId already exists in PRAWN and has been submitted with an OrganizationNameTransactionTypeCode of ADD.	N/A
BCH-0102	Please check the value of the OrganizationNameTransactionTypeCode tag (ORGANIZATION.TRANSACTION in the Notification Access Database). Generally, this error occurs if the related OrganizationId does not yet exist in PRAWN and has been submitted with an OrganizationNameTransactionTypeCode of EDIT.	N/A
BCH-0103	Please check the value of the OrganizationTypeCode tag (ORGANIZATION.ORGANIZATION_CODE in the Notification Access Database). Generally, this error is the result of a misspelling in of one of the valid values used to indicate Organization Type (most often 'STATE_AGENCY' is input instead of 'STATE_AGNCY', which is the correct value). Please see Chapter <b>Error! Reference source not found.</b> for additional information.	6
BCH-0201	Please check the value of the PersonNameTransactionTypeCode tag (PERSON.TRANSACTION in the Notification Access Database). Generally, this error occurs if the related PersonId already exists in PRAWN and has been submitted with an PersonNameTransactionTypeCode of ADD.	N/A
BCH-0202	Please check the value of the PersonNameTransactionTypeCode tag (PERSON.TRANSACTION in the Notification Access Database). Generally, this error occurs if the related PersonId does not yet exist in PRAWN and has been submitted with an PersonNameTransactionTypeCode of EDIT.	N/A
BCH-0301	Please check the value of the MailingAddressTypeCode tag (MAILING_ADDRESS.MAILING_ADDRESS_CODE in the Notification Access Database). Generally, this error is the result of a misspelling in of one of the valid values used to indicate Mailing Address Type. Please see Chapter <b>Error! Reference source not found.</b> for additional information.	7, 12
BCH-0302	Please check the value of the MailingAddressStateCode tag (MAILING_ADDRESS.STATE_POSTAL_CODE in the Notification Access Database). Generally, this error is the result of a misspelling in of one of the valid values used to indicate the correct state. Please confirm that a valid state code is being used.	7, 13
BCH-0303	Please check the value of the MailingAddressZipCode tag (MAILING_ADDRESS.ZIP_CODE in the Notification Access Database). Generally, this error is the result of an incorrectly formatted Zip Code. The correct formats are either '#####' (ZIP) or '#####-####' (ZIP+4). Please see Chapter <b>Error! Reference source not found.</b> for additional information.	8, 13
BCH-0401	Please check the value of the ElectronicAddressTypeCode tag (ELECTRONIC_ADDRESS.ELECTRONIC_ADDRESS_CODE in the Notification Access Database). Generally, this error is the result of a misspelling in of one of the valid values used to indicate Electronic Address Type Please see Chapter <b>Error! Reference source not found.</b> for additional information.	8, 13
BCH-0501	Please check the value of the TelephoneNumber tag (TELEPHONE.TELEPHONE_NUMBER in the Notification Access Database). Generally, this error is the result of an incorrectly formatted telephone number. The correct format is 'XXX-XXX-XXXX'. Please see Chapter <b>Error! Reference source not found.</b> for additional information.	9, 14



Error Code	Troubleshooting Tip	Page(s)
BCH-0502	Please check the value of the TelephoneTypeCode tag (TELEPHONE.TELEPHONE_CODE in the Notification Access Database). Generally, this error is the result of a misspelling in of one of the valid values used to indicate Telephone Type. Please see Chapter <b>Error! Reference source not found.</b> for additional information.	9, 14
BCH-0601	Please check the value of the ProgramInterestStateCode tag (BEACH.STATE_POSTAL_CODE in the Notification Access Database). Generally, this error is the result of a misspelling in of one of the valid values used to indicate the correct state. Please confirm that a valid state code is being used.	16
BCH-0602	Please check the value of the BeachNameTransactionTypeCode tag (BEACH.TRANSACTION in the Notification Access Database). Generally, this error occurs if the related BeachId already exists in PRAWN and has been submitted with a BeachNameTransactionTypeCode of ADD.	N/A
BCH-0603	Please check the value of the BeachNameTransactionTypeCode tag (BEACH.TRANSACTION in the Notification Access Database). Generally, this error occurs if the related BeachId has been registered with the EPA, but has not yet been submitted to PRAWN, and has been submitted with a BeachNameTransactionTypeCode of EDIT.	N/A
BCH-0604	Please check the value of the BeachIdentifier tag (BEACH.ID in the Notification Access Database). Generally, this error occurs if the related BeachId has not yet been registered with the EPA, or has been misspelled in the submission.	16
BCH-0605	Please check the value of the ProgramInterestFIPSCountyCode tag (BEACH.FIPS_COUNTY in the Notification Access Database). Generally, this error is the result of a misspelling in the standard 5-digit FIPS County Code. Please confirm that the correct FIPS Code is being used.	17
BCH-0606	Please check the value of the WaterBodyNameCode tag (BEACH.WATERBODY_NAME in the Notification Access Database) and the WaterBodyTypeCode tag (BEACH.WATERBODY_TYPE in the Notification Access Database). Generally, this error is the result of a misspelling in of one of the valid values used to indicate Water Body Name or Water Body Type. Please see Appendix D in the Beach Notification Data User Guide for additional information.	17
BCH-0607	Please check the value of the appropriate tag: ExtentLengthMeasure (BEACH_ATTRIBUTE.EXTENT_LENGTH in the Notification Access Database), SwimSeasonLengthMeasure (BEACH_ATTRIBUTE.SWIM_SEASON_LENGTH in the Notification Access Database), SwimSeasonFrequencyMeasure (BEACH_ATTRIBUTE.SWIM_MONITOR_FREQ in the Notification Access Database), OffSeasonFrequencyMeasure (BEACH_ATTRIBUTE.OFF_MONITOR_FREQ in the Notification Access Database) for the related year (AttributeEffectiveYear, BEACH_ATTRIBUTE.EFFECTIVE_YEAR in the Notification Access Database). Beach Attribute data (Beach Extent/Swim Season/Monitoring Frequencies) has already been submitted for this calendar year. If this is incorrect, or you have questions, please contact eBeaches@cgifederal.com.	19, 20, 22
BCH-0701	Please check the value of the ActivityTypeCode tag (BEACH_ACTIVITY.ACTIVITY_CODE in the Notification Access Database). Generally, this error is the result of a misspelling in of one of the valid values used to indicate Activity Type. Please check Chapter 3 and Appendix B in the Beach Notification Data User Guide for additional information.	26

<b>Error Code</b>	<b>Troubleshooting Tip</b>	<b>Page(s)</b>
BCH-0702	Please check the value of the ActivityMonitoringStationIdentifier tag (BEACH_ACTIVITY_STATION.STATION_ID in the Notification Access Database). Generally, this error occurs if the related StationId has not been properly formatted ("OrgId StationId"), has not yet been registered with STORET, or has been misspelled in the submission.	29
BCH-0703	Please check the value of the ActivityMonitoringStationIdentifier tag (BEACH_ACTIVITY_STATION.STATION_ID in the Notification Access Database). Generally, this error occurs if the related StationId has been omitted, but has also been known to occur if a BCH-0702 error (incorrectly formatted StationId) has occurred in the same submission.	29
BCH-0704	If the ActivityReasonType (BEACH_ACTIVITY_REASON.TYPE in the Notification Access Database where BEACH_ACTIVITY_REASON.CLASS = Reason), ActivitySourceType (BEACH_ACTIVITY_REASON.TYPE in the Notification Access Database where BEACH_ACTIVITY_REASON.CLASS = Source), or ActivityIndicatorType (BEACH_ACTIVITY_REASON.TYPE in the Notification Access Database where BEACH_ACTIVITY_REASON.CLASS = Indicator) are equal to OTHER, the corresponding description field must be filled in.	27, 28, 29
BCH-0705	The ActivityActualStartDate (BEACH_ACTIVITY.ACTUAL_START_DATE in the Notification Access Database) year does not match the ActivityActualStopDate ( in the Notification Access Database) year. Activities can only occur during one calendar year. In the event that an event does cross into another year, it must be split into two activities, one for each year.	27
BCH-0706	ActivityActualStartDate (BEACH_ACTIVITY.ACTUAL_START_DATE in the Notification Access Database) occurs after the ActivityActualStopDate ( in the Notification Access Database). The order of these dates must be reversed in order to achieve a successful submission.	27
BCH-0801	Please check the value of the BeachRoleTypeCode tag (BEACH_ORGANIZATION_ROLE_ASSIGN.ORG_ROLE_CODE and BEACH_PERSON_ROLE_ASSIGN.PERSON_ROLE_CODE in the Notification Access Database). Generally, this error is the result of a misspelling in of one of the valid values used to indicate Beach Role Type. Please check Chapter 3 in the Beach Notification Data User Guide for additional information.	32
BCH-0802	Please check that the OrganizationIdentifier (ORGANIZATION.ID in the Notification Access Database) has already been submitted to PRAWN. Generally this error occurs if the Organization in question does not already exist in PRAWN, but has also been known to occur if BCH-0101, BCH-0102, and/or BCH-0103 errors (related OrganizationIds) have occurred in the same submission.	6
BCH-0803	Please check that the PersonIdentifier (PERSON.ID in the Notification Access Database) has already been submitted to PRAWN. Generally this error occurs if the Person in question does not already exist in PRAWN, but has also been known to occur if BCH-0201 and/or BCH-0202 errors (related PersonIds) have occurred in the same submission.	11
BCH-0804	Please check the order of the Organization and Person assignments on a given beach. Persons cannot be assigned a role on a beach until the Organization they belong to has been assigned a role on that beach.	33
BCH-0901	Please check the value of the ProcedureTransactionTypeCode tag (PROCEDURE.TRANSACTION in the Notification Access Database). Generally, this error occurs if the related ProcedureId already exists in PRAWN and has been submitted with an ProcedureTransactionTypeCode of ADD.	N/A

---

Error Code	Troubleshooting Tip	Page(s)
BCH-0902	Please check the value of the ProcedureTransactionTypeCode tag (PROCEDURE.TRANSACTION in the Notification Access Database). Generally, this error occurs if the related OrganizationId does not yet exist in PRAWN and has been submitted with an ProcedureTransactionTypeCode of EDIT.	N/A
BCH-0903	Please check the value of the ProcedureTypeCode tag (PROCEDURE.PROCEDURE_CODE in the Notification Access Database). Generally, this error is the result of a misspelling in of one of the valid values used to indicate Procedure Type. Please see Appendix C in the Beach Notification Data User Guide for additional information.	37
BCH-0904	Please check to be sure that the BeachId listed in the ProcedureBeachIdentifier tag (BEACH_PROCEDURE_ASSIGN.FK_BEACH_ID in the Notification Access Database) has been entered into PRAWN. Generally, this error occurs if the related BeachId has not yet been submitted to PRAWN, but an association between a procedure and the related BeachId has been submitted.	37

---

### 4.3 Oracle Generated Error Messages

---

In addition to error messages generated by the PRAWN system, it is also possible that Oracle specific errors may occur during XML processing. These errors would most likely be associated with the administration and maintenance of the Oracle database instance (for example, exceeding the allocated table space size). Oracle specific errors will be captured by the XML data loading software and reported in the Error Log File together with the PRAWN system generated errors (see Section **Error! Reference source not found. Error! Reference source not found.**). Oracle specific errors will be prefixed with the text 'Oracle Error:' and will contain the error message number and text produced by the Oracle database at the time the error occurred.

---

## 5 How to Understand Beaches that are Similar Points of Access

This chapter provides detailed information regarding similar points of access. This chapter assumes that the XML submission has passed XML schema validation before being processed by the data loading software.

1. Enter Beach Information and Beach Attribute Information prior to Beach Extent Length, go to step 2.
2. Is this entry a SPA? If yes, you may enter an actual length that does not exceed: 100 ft. If no go to step 3.
3. Enter Beach Extent Length (note: a separate length will be calculated from your L/L data as indexed to the RAD to enable mapping and for allotment formula calculations.)
4. Enter Swim Season Monitoring Frequency and so on.

---

## 6 Appendix A—Schema Graphics

This appendix provides a graphical representation of the Beaches Notification v2.0 XML Schema. The figures that follow offer an expanded view of each of the four major sections that comprise a Beach Data Submission (Organization Detail, Person Detail, Beach Detail, and Beach Procedure Detail).

- Dashed lines represented optional elements, solid lines represent mandatory elements.
  - Please note: Empty tags (e.g., <BeachIdentifier></BeachIdentifier>) for optional elements cannot appear in the XML file.
- The figures 0..∞ and 1..∞ mean that the field may be repeated, as long as the repetitions are next to each other, as many times as the user wishes.
  - For example, a user may submit as many BeachDetail sections as necessary in a single file.
  - 1..∞ means that there must be at least one field included and 0..∞ means the field is entirely optional.
- A + sign at the end of the box means more elements exist under that element.

**Exhibit 6-1 Beach Data Submission**

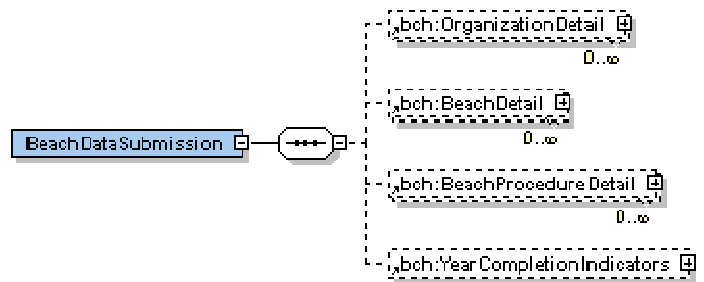

## Exhibit 6-2 Organization Detail

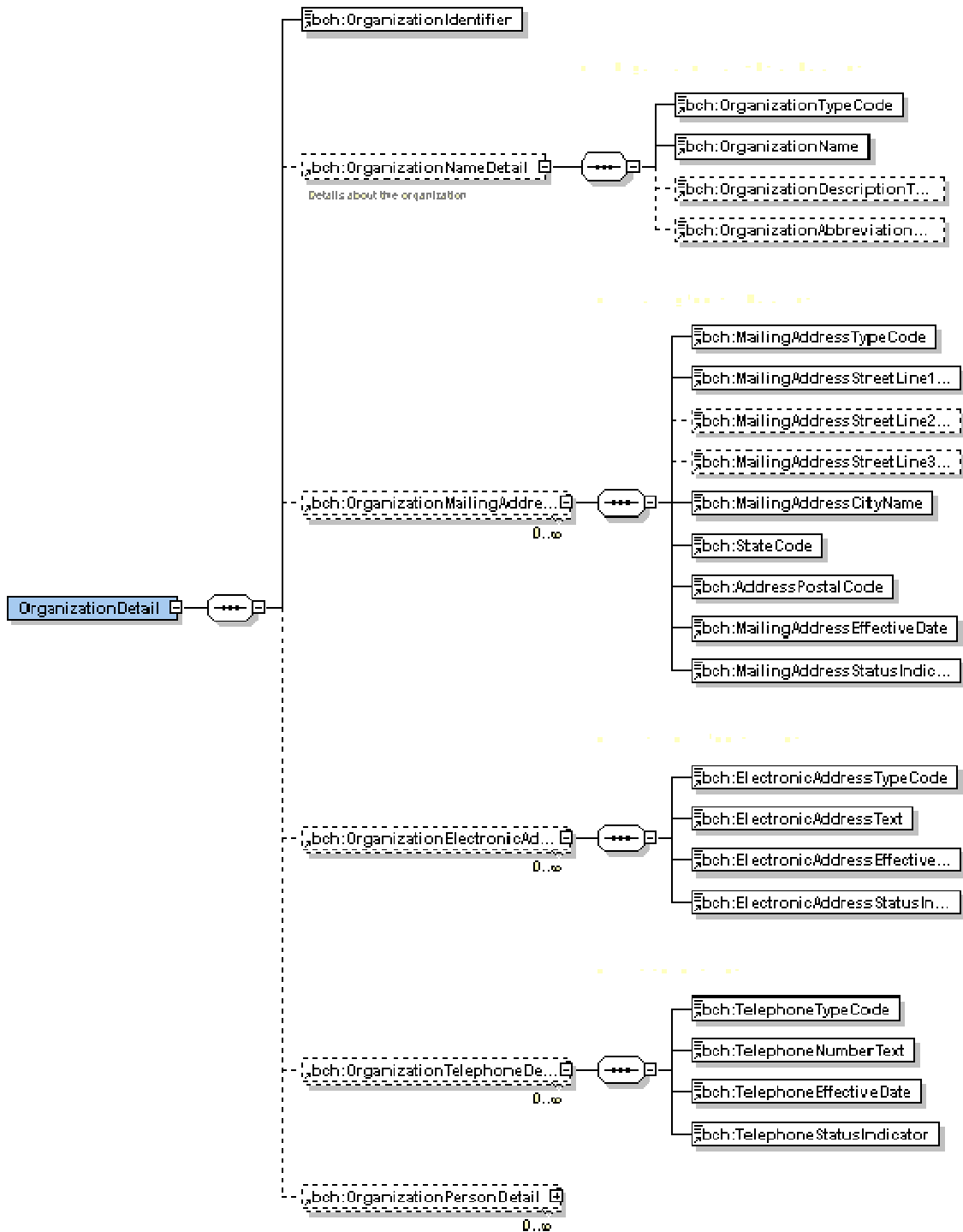

### Exhibit 6-3 Organization Person Detail

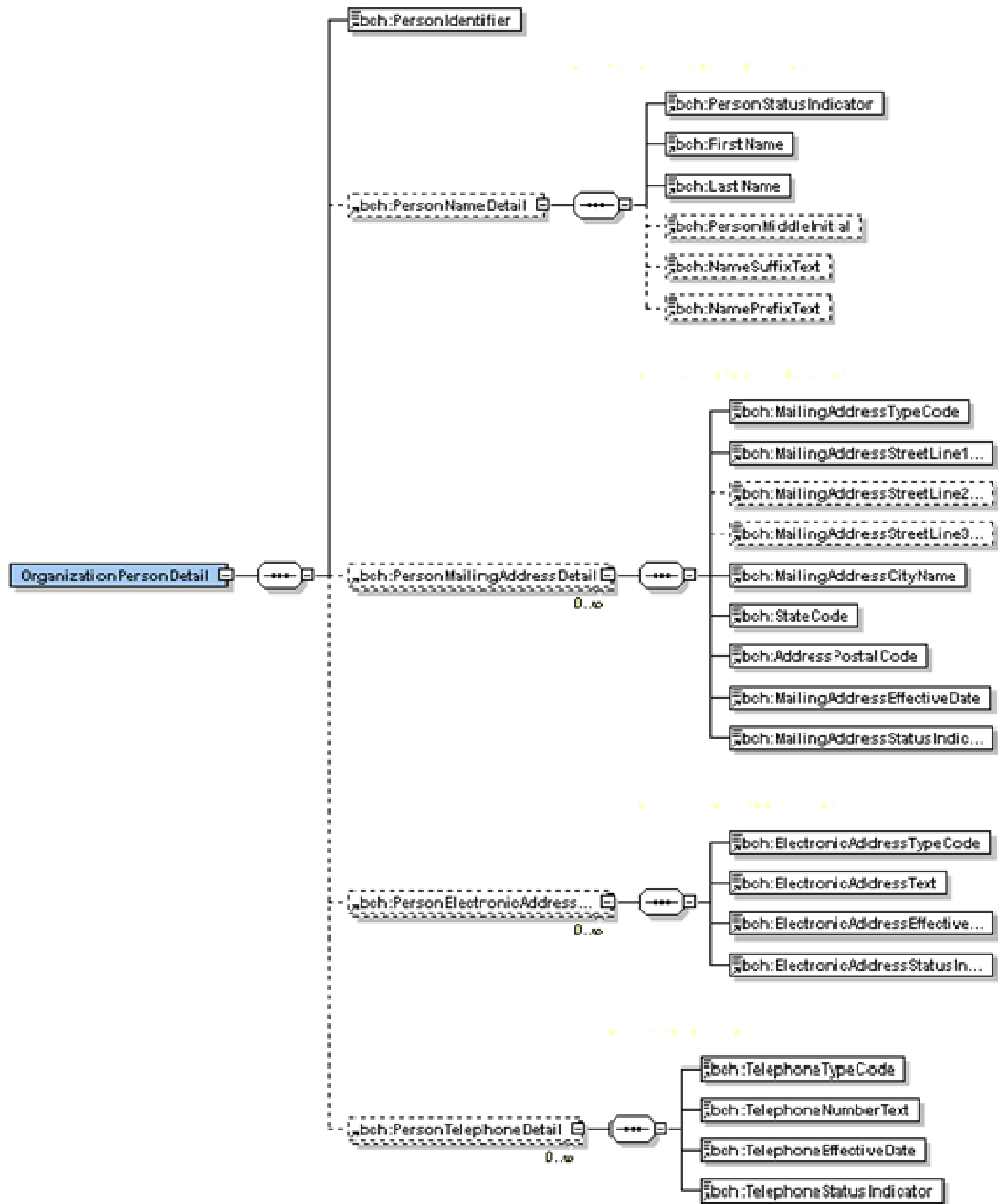

## Exhibit 6-4 Beach Name Detail

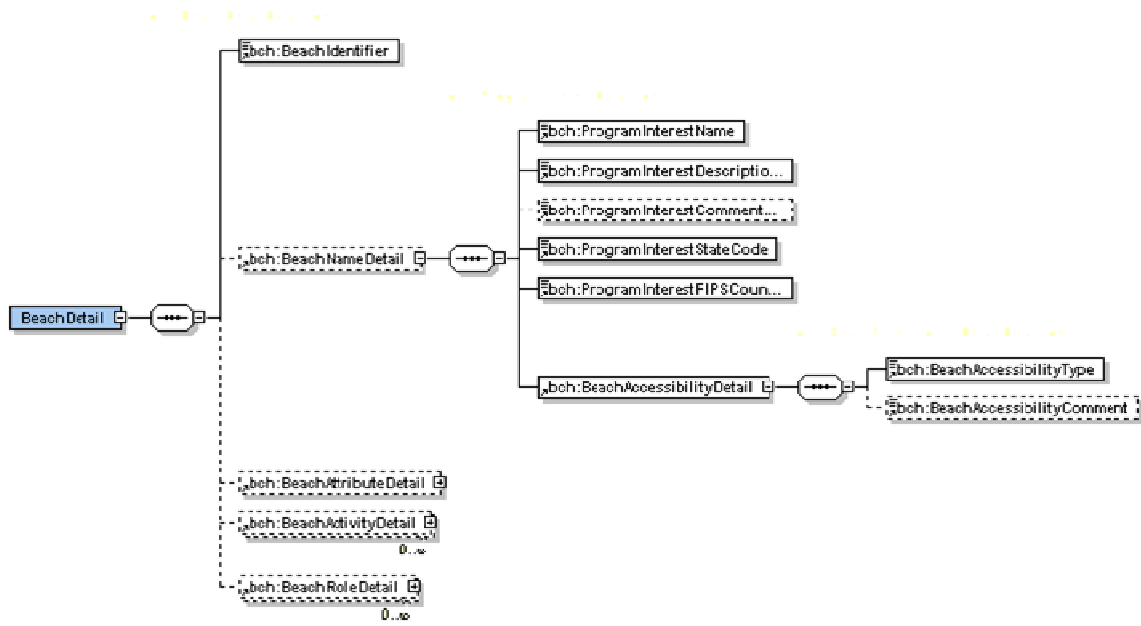



## Exhibit 6-5 Beach Attribute Detail

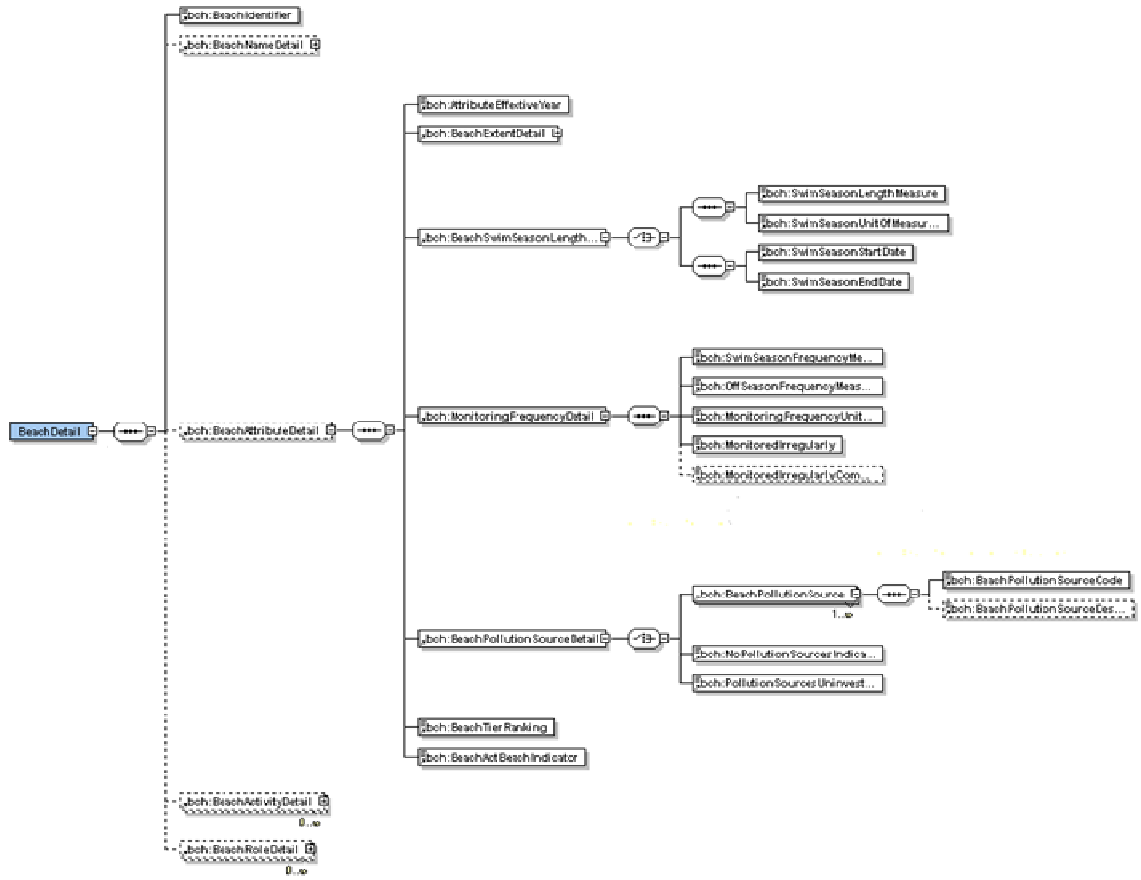

## Exhibit 6-5 Beach Activity Detail

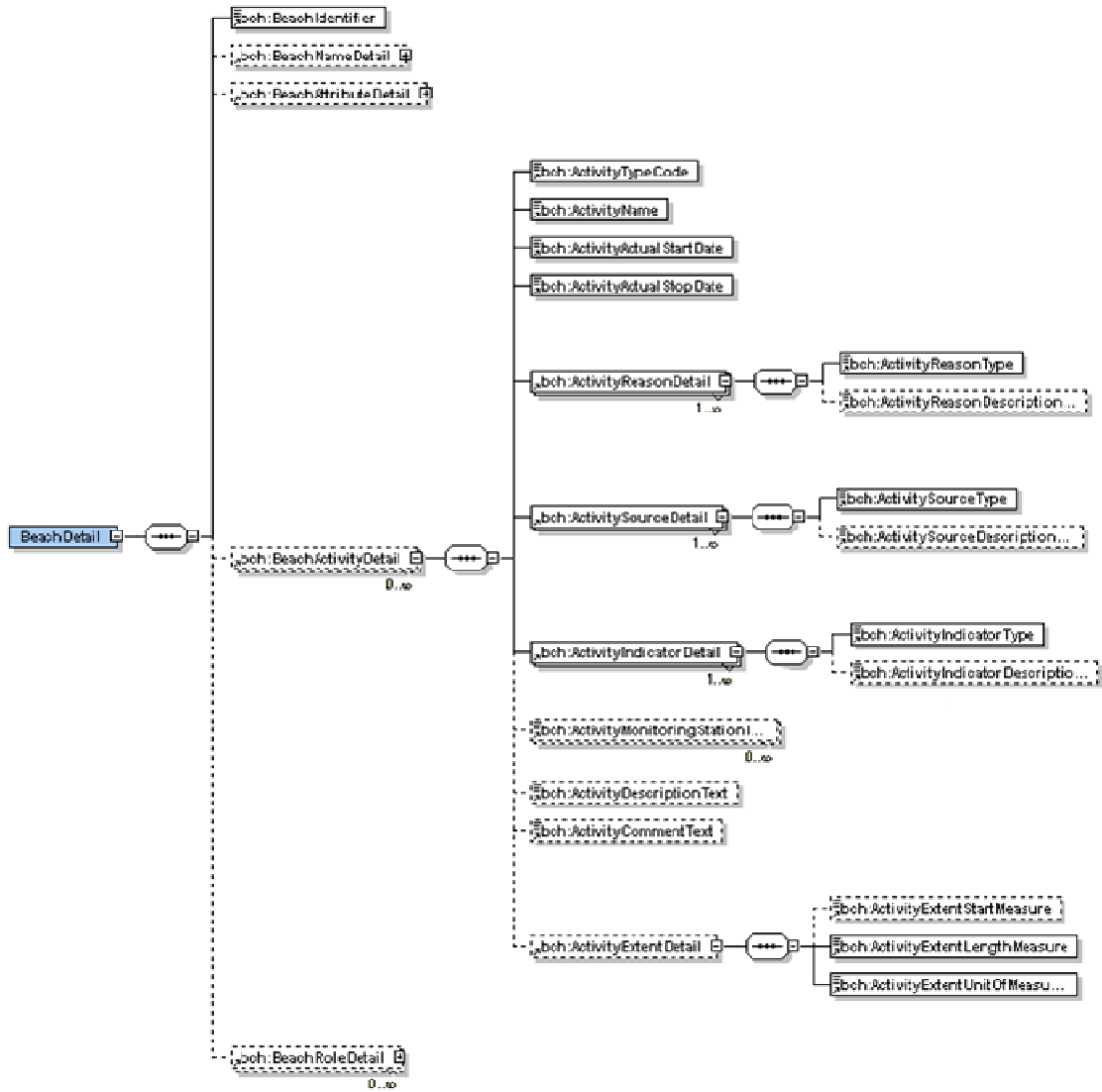

Exhibit 6-6 Beach Role Detail

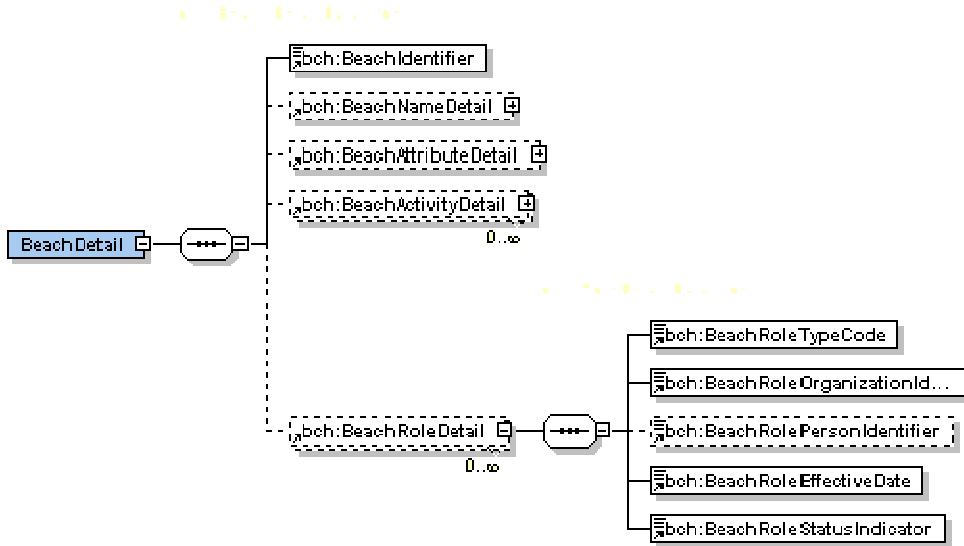
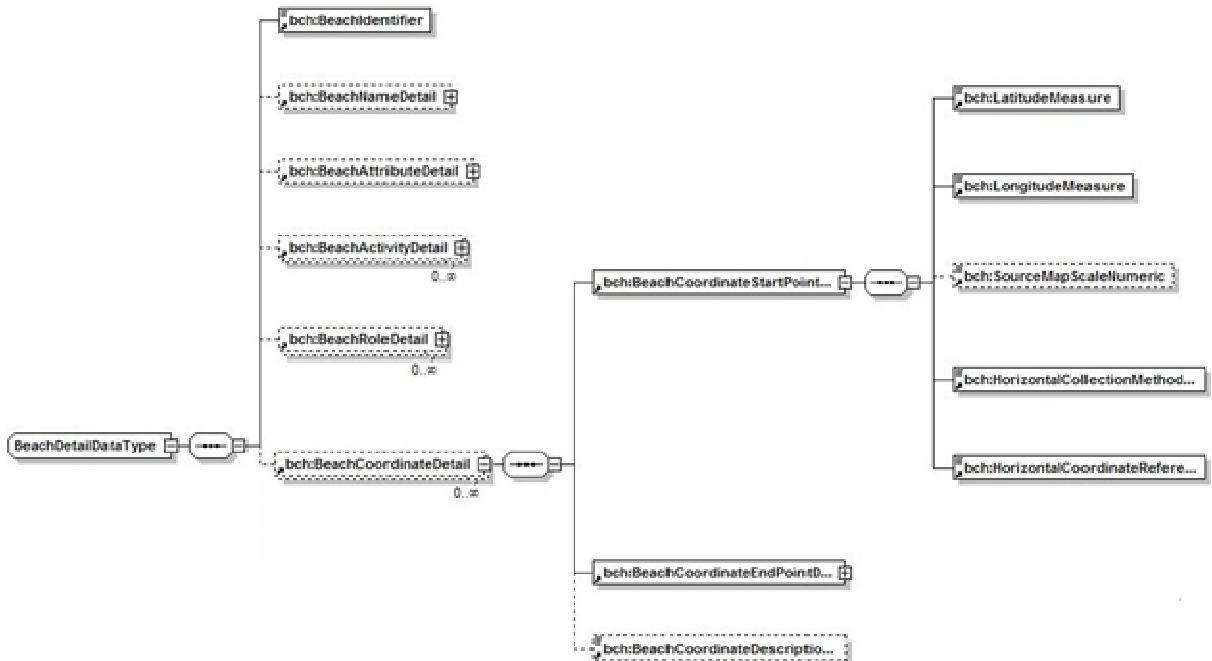
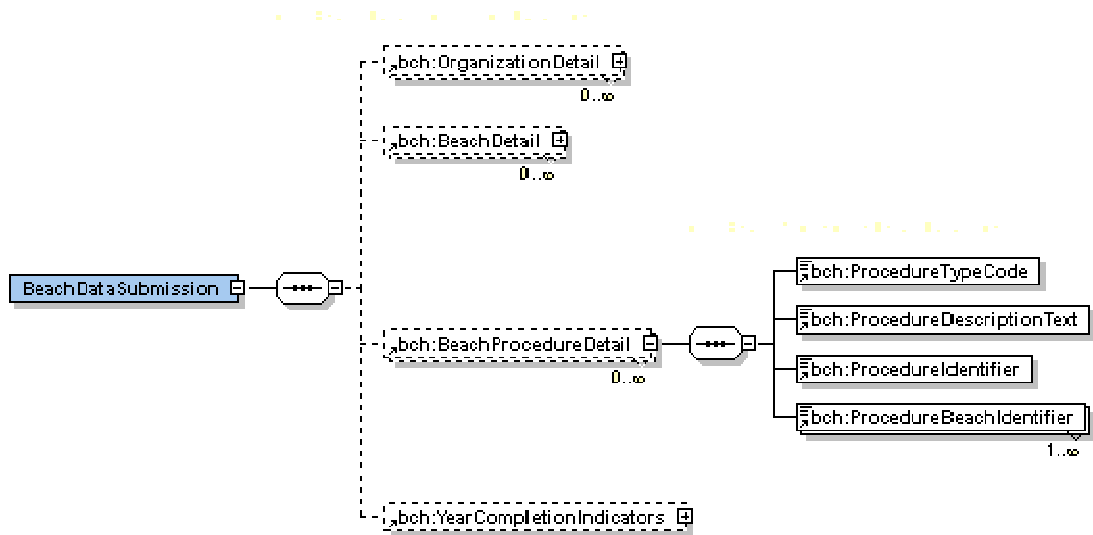

Exhibit 6-7 Beach Coordinate Detail



**Exhibit 6-8 Beach Procedure Detail**



**Exhibit 6-9 Year Completion Indicators**

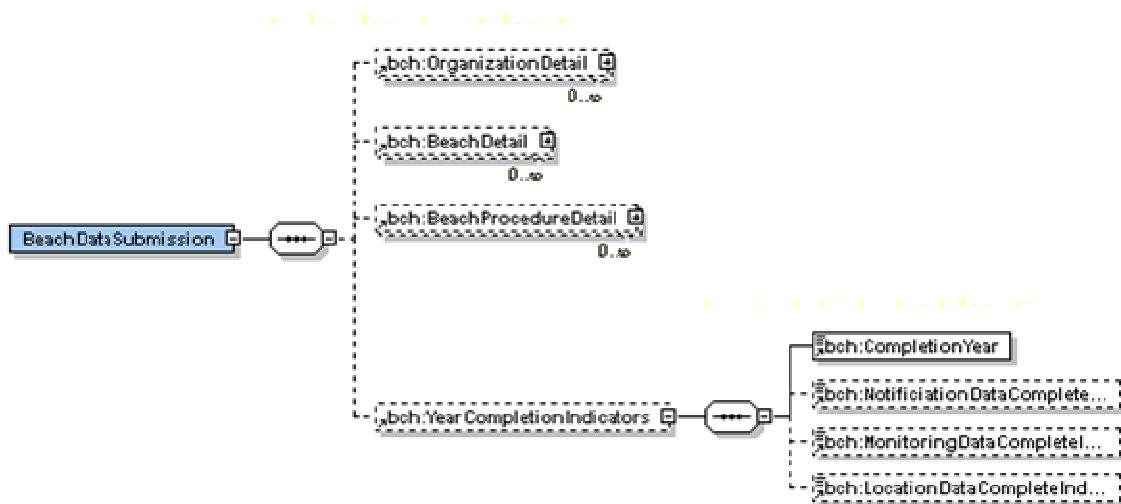

---

## 7 Appendix B—Example XML File

The following is text from an example XML file that would be sent to PRAWN from a State. The file appears with spacing to provide a more clear view of the data. The spacing is not required or standard.

```
<?xml version="1.0"?>
<!--Beach Data Submission created 11/15/2006 10:23:56 AM-->
<BeachDataSubmission xsi:schemaLocation="http://www.exchangenetwork.net/schema/BEACHES/2
index.xsd" xmlns="http://www.exchangenetwork.net/schema/BEACHES/2"
xmlns:xsi="http://www.w3.org/2001/XMLSchema-instance">
  <OrganizationDetail>
    <OrganizationIdentifier>2349fwe</OrganizationIdentifier>
    <OrganizationNameDetail>
      <OrganizationTypeCode>PRIVATE</OrganizationTypeCode>
      <OrganizationName>Tested</OrganizationName>
      <OrganizationDescriptionText>Testeddesc</OrganizationDescriptionText>
      <OrganizationAbbreviationText>TD</OrganizationAbbreviationText>
    </OrganizationNameDetail>
    <OrganizationMailingAddressDetail>
      <MailingAddressTypeCode>MAILING</MailingAddressTypeCode>
      <MailingAddressStreetLine1Text>123 Long
Drive</MailingAddressStreetLine1Text>
      <MailingAddressStreetLine2Text>Suite 534</MailingAddressStreetLine2Text>
      <MailingAddressStreetLine3Text>The Last
Stop</MailingAddressStreetLine3Text>
      <MailingAddressCityName>Testerville</MailingAddressCityName>
      <StateCode>VA</StateCode>
      <AddressPostalCode>45387</AddressPostalCode>
      <MailingAddressEffectiveDate>2002-05-05T12:00:00-
05:00</MailingAddressEffectiveDate>
      <MailingAddressStatusIndicator>ACTIVE</MailingAddressStatusIndicator>
    </OrganizationMailingAddressDetail>
    <OrganizationElectronicAddressDetail>
      <ElectronicAddressTypeCode>EMAIL</ElectronicAddressTypeCode>
      <ElectronicAddressText>my@my.com</ElectronicAddressText>
      <ElectronicAddressEffectiveDate>2001-01-
01T00:00:00</ElectronicAddressEffectiveDate>
      <ElectronicAddressStatusIndicator>ACTIVE</ElectronicAddressStatusIndicator>
    </OrganizationElectronicAddressDetail>
    <OrganizationTelephoneDetail>
      <TelephoneTypeCode>VOICE</TelephoneTypeCode>
      <TelephoneNumberText>123-456-7890</TelephoneNumberText>
      <TelephoneEffectiveDate>2001-01-01T00:00:00-05:00</TelephoneEffectiveDate>
      <TelephoneStatusIndicator>ACTIVE</TelephoneStatusIndicator>
    </OrganizationTelephoneDetail>
    <OrganizationPersonDetail>
      <PersonIdentifier>9e8ef7</PersonIdentifier>
      <PersonNameDetail>
        <PersonStatusIndicator>ACTIVE</PersonStatusIndicator>
        <FirstName>Johnny</FirstName>
        <LastName>Jones</LastName>
        <PersonMiddleInitial>J</PersonMiddleInitial>
        <NameSuffixText>Jr</NameSuffixText>
        <NamePrefixText>Mr.</NamePrefixText>
      </PersonNameDetail>
      <PersonMailingAddressDetail>
        <MailingAddressTypeCode>MAILING</MailingAddressTypeCode>
        <MailingAddressStreetLine1Text>830 My
Drive</MailingAddressStreetLine1Text>
        <MailingAddressStreetLine2Text>Suite
223</MailingAddressStreetLine2Text>
        <MailingAddressStreetLine3Text>The last
row</MailingAddressStreetLine3Text>
        <MailingAddressCityName>The Big House</MailingAddressCityName>
```

---

```

        <StateCode>VA</StateCode>
        <AddressPostalCode>27886</AddressPostalCode>
        <MailingAddressEffectiveDate>2001-01-01T12:00:00-
05:00</MailingAddressEffectiveDate>

        <MailingAddressStatusIndicator>ACTIVE</MailingAddressStatusIndicator>
        </PersonMailingAddressDetail>
        <PersonElectronicAddressDetail>
            <ElectronicAddressTypeCode>EMAIL</ElectronicAddressTypeCode>

            <ElectronicAddressText>agnes.flemming@vdh.virginia.gov</ElectronicAddressText>
            <ElectronicAddressEffectiveDate>2001-01-01T12:00:00-
05:00</ElectronicAddressEffectiveDate>

            <ElectronicAddressStatusIndicator>ACTIVE</ElectronicAddressStatusIndicator>
            </PersonElectronicAddressDetail>
            <PersonTelephoneDetail>
                <TelephoneTypeCode>VOICE</TelephoneTypeCode>
                <TelephoneNumberText>617-254-0845</TelephoneNumberText>
                <TelephoneEffectiveDate>2001-01-
01T00:00:00</TelephoneEffectiveDate>
                <TelephoneStatusIndicator>ACTIVE</TelephoneStatusIndicator>
            </PersonTelephoneDetail>
        </OrganizationPersonDetail>
    </OrganizationDetail>
    <OrganizationDetail>
        <OrganizationIdentifier>394e785</OrganizationIdentifier>
        <OrganizationNameDetail>
            <OrganizationTypeCode>LOCAL_GOV</OrganizationTypeCode>
            <OrganizationName>testing</OrganizationName>
            <OrganizationDescriptionText>testingdesc</OrganizationDescriptionText>
            <OrganizationAbbreviationText>T</OrganizationAbbreviationText>
        </OrganizationNameDetail>
        <OrganizationPersonDetail>
            <PersonIdentifier>foi34e0</PersonIdentifier>
            <PersonNameDetail>
                <PersonStatusIndicator>ACTIVE</PersonStatusIndicator>
                <FirstName>Chris</FirstName>
                <LastName>Johnson</LastName>
                <NamePrefixText>Manager</NamePrefixText>
            </PersonNameDetail>
        </OrganizationPersonDetail>
        <OrganizationPersonDetail>
            <PersonIdentifier>JH</PersonIdentifier>
            <PersonNameDetail>
                <PersonStatusIndicator>ACTIVE</PersonStatusIndicator>
                <FirstName>Jill</FirstName>
                <LastName>Holander</LastName>
            </PersonNameDetail>
            <PersonElectronicAddressDetail>
                <ElectronicAddressTypeCode>EMAIL</ElectronicAddressTypeCode>
                <ElectronicAddressText>my@my.com</ElectronicAddressText>
                <ElectronicAddressEffectiveDate>2001-01-
01T00:00:00</ElectronicAddressEffectiveDate>

                <ElectronicAddressStatusIndicator>ACTIVE</ElectronicAddressStatusIndicator>
            </PersonElectronicAddressDetail>
        </OrganizationPersonDetail>
    </OrganizationDetail>
    <BeachDetail>
        <BeachIdentifier>AK162093</BeachIdentifier>
        <BeachNameDetail>
            <ProgramInterestName>Demo Beach</ProgramInterestName>
            <ProgramInterestDescriptionText>For
Demonstration</ProgramInterestDescriptionText>
            <ProgramInterestCommentText>Delete this
record.</ProgramInterestCommentText>
            <ProgramInterestStateCode>NV</ProgramInterestStateCode>
            <ProgramInterestFIPSCountyCode>21000</ProgramInterestFIPSCountyCode>
            <WaterBodyNameCode>ATLANTIC</WaterBodyNameCode>
            <WaterBodyTypeCode>OPEN_COAST</WaterBodyTypeCode>

```

---

```

        <BeachAccessibilityDetail>
            <BeachAccessibilityType>PUB_PUB_ACC</BeachAccessibilityType>
            <BeachAccessibilityComment>Test
Comment.</BeachAccessibilityComment>
        </BeachAccessibilityDetail>
    </BeachNameDetail>
    <BeachAttributeDetail>
        <AttributeEffectiveYear>2002</AttributeEffectiveYear>
        <BeachExtentDetail>
            <ExtentLengthMeasure>28.45</ExtentLengthMeasure>
            <ExtentUnitOfMeasureCode>MI</ExtentUnitOfMeasureCode>
        </BeachExtentDetail>
        <BeachSwimSeasonLengthDetail>
            <SwimSeasonStartDate>2001-05-01</SwimSeasonStartDate>
            <SwimSeasonEndDate>2001-09-30</SwimSeasonEndDate>
        </BeachSwimSeasonLengthDetail>
        <!-- Although discouraged, BeachSwimSeason is also allowed to be in the
form

        <BeachSwimSeasonLengthDetail>
            <SwimSeasonLengthMeasure>3</SwimSeasonLengthMeasure>
            <SwimSeasonUnitOfMeasureCode>MONTHS</SwimSeasonUnitOfMeasureCode>
        </BeachSwimSeasonLengthDetail>
        -->
        <MonitoringFrequencyDetail>
            <SwimSeasonFrequencyMeasure>3</SwimSeasonFrequencyMeasure>
            <OffSeasonFrequencyMeasure>1</OffSeasonFrequencyMeasure>

            <MonitoringFrequencyUnitOfMeasureCode>PER_WEEK</MonitoringFrequencyUnitOfMeasureCode>
            <MonitoredIrregularly>true</MonitoredIrregularly>
            <MonitoredIrregularlyComment>This beach is also monitored whenever
there is heavy rain.</MonitoredIrregularlyComment>
        </MonitoringFrequencyDetail>
        <!--
        <MonitoringFrequencyDetail>
            <MonitoredIrregularly>true</MonitoredIrregularly>
        </MonitoringFrequencyDetail>
        -->
        <BeachPollutionSourceDetail>
            <BeachPollutionSource>
                <BeachPollutionSourceCode>CS0</BeachPollutionSourceCode>
                <BeachPollutionSourceDescription>Comment for
CS0</BeachPollutionSourceDescription>
            </BeachPollutionSource>
            <BeachPollutionSource>
                <BeachPollutionSourceCode>POTW</BeachPollutionSourceCode>
                <BeachPollutionSourceDescription>Comment for
POTW</BeachPollutionSourceDescription>
            </BeachPollutionSource>
        <!--

            <NoPollutionSourcesIndicator>true</NoPollutionSourcesIndicator>

        <PollutionSourcesUninvestigatedIndicator>true</PollutionSourcesUninvestigatedIndicator>

        -->
    </BeachPollutionSourceDetail>
    <BeachTierRanking>3</BeachTierRanking>
    <BeachActBeachIndicator>true</BeachActBeachIndicator>
</BeachAttributeDetail>
<BeachActivityDetail>
    <ActivityTypeCode>CLOSURE</ActivityTypeCode>
    <ActivityName>Demo Activity 1</ActivityName>
    <ActivityActualStartDate>2002-01-01T08:30:00</ActivityActualStartDate>
    <ActivityActualStopDate>2003-01-01T23:59:59</ActivityActualStopDate>
    <ActivityReasonDetail>
        <ActivityReasonType>ELEV_BACT</ActivityReasonType>
        <ActivityReasonDescriptionText>Demo
Description</ActivityReasonDescriptionText>
    </ActivityReasonDetail>
    <ActivitySourceDetail>

```

---

```

                <ActivitySourceType>SEWER_LINE</ActivitySourceType>
                <ActivitySourceDescriptionText>Shut her down Clancy, she's pumpin'
mud!</ActivitySourceDescriptionText>
            </ActivitySourceDetail>
            <ActivityIndicatorDetail>
                <ActivityIndicatorType>OTHER</ActivityIndicatorType>
                <ActivityIndicatorDescriptionText>Demo Description
2</ActivityIndicatorDescriptionText>
            </ActivityIndicatorDetail>

            <ActivityMonitoringStationIdentifier>NV004|rs001</ActivityMonitoringStationIdentifier>

            <ActivityMonitoringStationIdentifier>NV004|rs002</ActivityMonitoringStationIdentifier>
            <ActivityDescriptionText>Demo activity
description</ActivityDescriptionText>
            <ActivityCommentText>Demo</ActivityCommentText>
            <ActivityExtentDetail>
                <ActivityExtentStartMeasure>4</ActivityExtentStartMeasure>
                <ActivityExtentLengthMeasure>16</ActivityExtentLengthMeasure>

            <ActivityExtentUnitOfMeasureCode>MI</ActivityExtentUnitOfMeasureCode>
            </ActivityExtentDetail>
        </BeachActivityDetail>
        <BeachRoleDetail>
            <BeachRoleTypeCode>COLLECTOR</BeachRoleTypeCode>
            <BeachRoleOrganizationIdentifier>2349fwe</BeachRoleOrganizationIdentifier>
            <BeachRolePersonIdentifier>SD</BeachRolePersonIdentifier>
            <BeachRoleEffectiveDate>2001-01-01T00:00:00</BeachRoleEffectiveDate>
            <BeachRoleStatusIndicator>ACTIVE</BeachRoleStatusIndicator>
        </BeachRoleDetail>
        <BeachRoleDetail>
            <BeachRoleTypeCode>ANALYZER</BeachRoleTypeCode>
            <BeachRoleOrganizationIdentifier>394e785</BeachRoleOrganizationIdentifier>
            <BeachRoleEffectiveDate>2006-01-01T00:00:00</BeachRoleEffectiveDate>
            <BeachRoleStatusIndicator>ACTIVE</BeachRoleStatusIndicator>
        </BeachRoleDetail>
        <BeachRoleDetail>
            <BeachRoleTypeCode>ANALYZER</BeachRoleTypeCode>
            <BeachRoleOrganizationIdentifier>394e785</BeachRoleOrganizationIdentifier>
            <BeachRolePersonIdentifier>JH</BeachRolePersonIdentifier>
            <BeachRoleEffectiveDate>2001-01-01T00:00:00</BeachRoleEffectiveDate>
            <BeachRoleStatusIndicator>ACTIVE</BeachRoleStatusIndicator>
        </BeachRoleDetail>
    </BeachDetail>
    <BeachDetail>
        <BeachIdentifier>AK177449</BeachIdentifier>
        <BeachNameDetail>
            <ProgramInterestName>test</ProgramInterestName>
            <ProgramInterestDescriptionText>test</ProgramInterestDescriptionText>
            <ProgramInterestCommentText>test</ProgramInterestCommentText>
            <ProgramInterestStateCode>NV</ProgramInterestStateCode>
            <ProgramInterestFIPSCountyCode>21000</ProgramInterestFIPSCountyCode>
            <WaterBodyNameCode>ATLANTIC</WaterBodyNameCode>
            <WaterBodyTypeCode>OPEN_COAST</WaterBodyTypeCode>
            <BeachAccessibilityDetail>
                <BeachAccessibilityType>PUB_PUB_ACC</BeachAccessibilityType>
                <BeachAccessibilityComment>Test
Comment.</BeachAccessibilityComment>
            </BeachAccessibilityDetail>
        </BeachNameDetail>
        <BeachRoleDetail>
            <BeachRoleTypeCode>TESTOR</BeachRoleTypeCode>
            <BeachRoleOrganizationIdentifier>394e785</BeachRoleOrganizationIdentifier>
            <BeachRolePersonIdentifier>foi34e0</BeachRolePersonIdentifier>
            <BeachRoleEffectiveDate>2001-01-01T00:00:00</BeachRoleEffectiveDate>
            <BeachRoleStatusIndicator>ACTIVE</BeachRoleStatusIndicator>
        </BeachRoleDetail>
        <BeachCoordinateDetail>
            <BeachCoordinateStartPointDetail>
                <LatitudeMeasure>34.141592</LatitudeMeasure>
                <LongitudeMeasure>-74.141592</LongitudeMeasure>

```



---

```

        <SourceMapScaleNumeric>12500</SourceMapScaleNumeric>
        <HorizontalCollectionMethodName>INTERPOLATION-
MAP</HorizontalCollectionMethodName>

        <HorizontalCoordinateReferenceSystemDatumName>NAD27</HorizontalCoordinateReferenceSystemD
atumName>
        </BeachCoordinateStartPointDetail>
        <BeachCoordinateEndPointDetail>
            <LatitudeMeasure>36.564398</LatitudeMeasure>
            <LongitudeMeasure>-44.124812</LongitudeMeasure>
            <SourceMapScaleNumeric>12500</SourceMapScaleNumeric>
            <HorizontalCollectionMethodName>INTERPOLATION-
MAP</HorizontalCollectionMethodName>

        <HorizontalCoordinateReferenceSystemDatumName>NAD27</HorizontalCoordinateReferenceSystemD
atumName>
        </BeachCoordinateEndPointDetail>
        <BeachCoordinateDescriptionText>Short
description.</BeachCoordinateDescriptionText>
        </BeachCoordinateDetail>
    </BeachDetail>
    <BeachProcedureDetail>
        <ProcedureTypeCode>DA_ASES_RISK</ProcedureTypeCode>
        <ProcedureDescriptionText>Our Procedure to Assess Risk</ProcedureDescriptionText>
        <ProcedureIdentifier>PRESS_RELEASE</ProcedureIdentifier>
        <ProcedureBeachIdentifier>AK162093</ProcedureBeachIdentifier>
        <ProcedureBeachIdentifier>AK162093</ProcedureBeachIdentifier>
    </BeachProcedureDetail>
    <YearCompletionIndicators>
        <CompletionYear>2008</CompletionYear>
        <NotificiationDataCompleteIndicator>true</NotificiationDataCompleteIndicator>
        <MonitoringDataCompleteIndicator>true</MonitoringDataCompleteIndicator>
        <LocationDataCompleteIndicator>true</LocationDataCompleteIndicator>
    </YearCompletionIndicators>
</BeachDataSubmission>

```

---

## 8 Appendix C—Procedure Type Codes

Due to the large number of Procedure Type codes, this appendix provides a separate table to explain the acceptable codes. See Section **Error! Reference source not found.** for a description of when to use these codes in the XML schema.

<b>Code</b>	<b>Name</b>	<b>Description</b>
DA_ASES_RISK	ADVISORY: Assess risk	Assess risks to potential swimmers
DA_ASES_SICK	ADVISORY: Asses sickness	Assess number of complaints of sickness
DA_DIS_AGENCY	ADVISORY: Discuss with agencies	Discuss situation with other agencies
DA_PRECAUTN	ADVISORY: Precautionary	Perform a precautionary closing in response to hazardous discharges
DA_PREEMPTVE	ADVISORY: Preemptive	Compare conditions to preemptive closing criteria
DA_WTR_STAND	ADVISORY: Compare with water standards	Compare bacterial concentrations with water quality standards to determine whether standards are exceeded
DA_W_Q_MONTR	ADVISORY: Water quality monitoring	Perform water quality modeling
DB_ASES_RISK	COMBINED: Assess risk	Assess risks to potential swimmers
DB_ASES_SICK	COMBINED: Asses sickness	Assess number of complaints of sickness
DB_DIS_AGENCY	COMBINED: Discuss with agencies	Discuss situation with other agencies
DB_PRECAUTN	COMBINED: Precautionary	Perform a precautionary closing in response to hazardous discharges
DB_PREEMPTVE	COMBINED: Preemptive	Compare conditions to preemptive closing criteria
DB_WTR_STAND	COMBINED: Compare with water standards	Compare bacterial concentrations with water quality standards to determine whether standards are exceeded
DB_W_Q_MONTR	COMBINED: Water quality monitoring	Perform water quality modeling

<b>Code</b>	<b>Name</b>	<b>Description</b>
DC_ASES_RISK	CLOSING: Assess risk	Assess risks to potential swimmers
DC_ASES_SICK	CLOSING: Asses sickness	Assess number of complaints of sickness
DC_DIS_AGENCY	CLOSING: Discuss with agencies	Discuss situation with other agencies
DC_PRECAUTN	CLOSING: Precautionary	Perform a precautionary closing in response to hazardous discharges
DC_PREEMPTVE	CLOSING: Preemptive	Compare conditions to preemptive closing criteria
DC_WTR_STAND	CLOSING: Compare with water standards	Compare bacterial concentrations with water quality standards to determine whether standards are exceeded
DC_W_Q_MONTR	CLOSING: Water quality monitoring	Perform water quality modeling
IA_BEACH	ADVISORY: Post at Beach	Post advisory or closing at the beach
IA_DIF_AGENCY	ADVISORY: Different Agency(ies)	Provide announcement to other government agency(ies)
IA_INTERNAL	ADVISORY: Internal Agency	Provide announcement to internal agency staff
IA_INTERNET	ADVISORY: Post on Internet	Post advisory or closing on the Internet
IA_NEWSPAPER	ADVISORY: Newspaper article	Publish advisory or closing in local newspaper
IA_PHONE	ADVISORY: Provide phone line	Provide results on hotline/water quality information/result phone line
IA_PHYS_ISOL	ADVISORY: Physical Isolation	Physically isolate contaminated area (e.g., block access, fence off area)
IA_RADIO	ADVISORY: Radio announcement	Have advisory or closing announced on local radio station
IA_RESP_PRSN	ADVISORY: Notify responsible person	Notify owner/manager/operator/lifeguards of results

---

<b>Code</b>	<b>Name</b>	<b>Description</b>
IA_TV_ANNCE	ADVISORY: TV announcement	Have advisory or closing announced on local TV station
IB_BEACH	COMBINED: Post at Beach	Post advisory or closing at the beach
IB_DIF_AGNCY	COMBINED: Different Agency(ies)	Provide announcement to other government agency(ies)
IB_INTERNAL	COMBINED: Internal Agency	Provide announcement to internal agency staff
IB_INTERNET	COMBINED: Post on Internet	Post advisory or closing on the Internet
IB_NEWSPAPER	COMBINED: Newspaper article	Publish advisory or closing in local newspaper
IB_PHONE	COMBINED: Provide phone line	Provide results on hotline/water quality information/result phone line
IB_PHYS_ISOL	COMBINED: Physical Isolation	Physically isolate contaminated area (e.g., block access, fence off area)
IB_RADIO	COMBINED: Radio announcement	Have advisory or closing announced on local radio station
IB_RESP_PRSN	COMBINED: Notify responsible person	Notify owner/manager/operator/lifeguards of results
IB_TV_ANNCE	COMBINED: TV announcement	Have advisory or closing announced on local TV station
IC_BEACH	CLOSING: Post at Beach	Post advisory or closing at the beach
IC_DIF_AGNCY	CLOSING: Different Agency(ies)	Provide announcement to other government agency(ies)
IC_INTERNAL	CLOSING: Internal Agency	Provide announcement to internal agency staff
IC_INTERNET	CLOSING: Post on Internet	Post advisory or closing on the Internet

---

---

<b>Code</b>	<b>Name</b>	<b>Description</b>
IC_NEWSPAPER	CLOSING: Newspaper article	Publish advisory or closing in local newspaper
IC_PHONE	CLOSING: Provide phone line	Provide results on hotline/water quality information/result phone line
IC_PHYS_ISOL	CLOSING: Physical Isolation	Physically isolate contaminated area (e.g., block access, fence off area)
IC_RADIO	CLOSING: Radio announcement	Have advisory or closing announced on local radio station
IC_RESP_PRSN	CLOSING: Notify responsible person	Notify owner/manager/operator/lifeguards of results
IC_TV_ANNCE	CLOSING: TV announcement	Have advisory or closing announced on local TV station
MO_BEACH	Post at Beach	Post results at beach
MO_DIF_AGENCY	Different Agency	Provide results to different agency staff for evaluation
MO_INTERNAL	Internal Agency	Provide results to internal agency staff for evaluation
MO_INTERNET	Post on article	Post results on the Internet
MO_NEWSPAPER	Newspaper article	Publish results in local newspaper
MO_ON_REQUEST	Provide on request	Provide results to anyone on request
MO_PHONE	Provide phone line	Provide results on hotline/water quality information/results/phone line
MO_RADIO	Radio announcement	Have results announced on local radio station
MO_RESP_PRSN	Notify responsible person	Notify owner/manager/operator/lifeguards of results
MO_TV_ANNCE	TV announcement	Have results announced on local TV station
OT_OTHER	Other	Other
RA_ASES_RISK	ADVISORY: Assess risks	Assess risks to potential swimmers
RA_ASES_SICK	ADVISORY: Assess sickness	Assess number of complaints of sickness

<b>Code</b>	<b>Name</b>	<b>Description</b>
RA_BEACH	ADVISORY: Post at beach	Post announcement at the beach
RA_DIF_AGENCY	ADVISORY: Discuss with agencies	Discuss situation with other agencies
RA_INTERNAL	ADVISORY: Agency	Provide announcement to agency staff
RA_INTERNET	ADVISORY: Post on Internet	Post reopening on the Internet
RA_LOCAL_GOV	ADVISORY: Local government	Provide announcement to local government staff
RA_NEWSPAPER	ADVISORY: Newspaper article	Publish reopening in local newspaper
RA_PHONE	ADVISORY: Provide phone line	Provide results on hotline/water quality information/result phone line
RA_PHYS_ISOL	ADVISORY: Remove physical isolation	Remove physical barriers set when closed
RA_RADIO	ADVISORY: Radio announcement	Have reopening announced on local radio station
RA_RESAMPLE	ADVISORY: Resample	Resample and compare bacterial concentrations with water quality standards to determine whether levels are below
RA_RESP_PRSN	ADVISORY: Notify responsible person	Notify owner/manager/operator/lifeguards of results
RA_STD_RAIN	ADVISORY: Standard rain reopening	Reopen after a set number of days following rainfall
RA_TV_ANNCE	ADVISORY: TV announcement	Have reopening announced on local TV station
RB_ASES_RISK	COMBINED: Assess risks	Assess risks to potential swimmers
RB_ASES_SICK	COMBINED: Assess sickness	Assess number of complaints of sickness
RB_BEACH	COMBINED: Post at beach	Post announcement at the beach

<b>Code</b>	<b>Name</b>	<b>Description</b>
RB_DIF_AGENCY	COMBINED: Discuss with agencies	Discuss situation with other agencies
RB_INTERNAL	COMBINED: Agency	Provide announcement to agency staff
RB_INTERNET	COMBINED: Post on Internet	Post reopening on the Internet
RB_LOCAL_GOV	COMBINED: Local government	Provide announcement to local government staff
RB_NEWSPAPER	COMBINED: Newspaper article	Publish reopening in local newspaper
RB_PHONE	COMBINED: Provide phone line	Provide results on hotline/water quality information/result phone line
RB_PHYS_ISOL	COMBINED: Remove physical isolation	Remove physical barriers set when closed
RB_RADIO	COMBINED: Radio announcement	Have reopening announced on local radio station
RB_RESAMPLE	COMBINED: Resample	Resample and compare bacterial concentrations with water quality standards to determine whether levels are below
RB_RESP_PRSN	COMBINED: Notify responsible person	Notify owner/manager/operator/lifeguards of results
RB_STD_RAIN	COMBINED: Standard rain reopening	Reopen after a set number of days following rainfall
RB_TV_ANNCE	COMBINED: TV announcement	Have reopening announced on local TV station
RC_ASES_RISK	CLOSING: Assess risks	Assess risks to potential swimmers
RC_ASES_SICK	CLOSING: Assess sickness	Assess number of complaints of sickness
RC_BEACH	CLOSING: Post at beach	Post announcement at the beach
RC_DIF_AGENCY	CLOSING: Discuss with agencies	Discuss situation with other agencies

---

<b>Code</b>	<b>Name</b>	<b>Description</b>
RC_INTERNAL	CLOSING: Agency	Provide announcement to agency staff
RC_INTERNET	CLOSING: Post on Internet	Post reopening on the Internet
RC_LOCAL_GOV	CLOSING: Local government	Provide announcement to local government staff
RC_NEWSPAPER	CLOSING: Newspaper article	Publish reopening in local newspaper
RC_PHONE	CLOSING: Provide phone line	Provide results on hotline/water quality information/result phone line
RC_PHYS_ISOL	CLOSING: Remove physical isolation	Remove physical barriers set when closed
RC_RADIO	CLOSING: Radio announcement	Have reopening announced on local radio station
RC_RESAMPLE	CLOSING: Resample	Resample and compare bacterial concentrations with water quality standards to determine whether levels are below
RC_RESP_PRSN	CLOSING: Notify responsible person	Notify owner/manager/operator/lifeguards of results
RC_STD_RAIN	CLOSING: Standard rain reopening	Reopen after a set number of days following rainfall
RC_TV_ANNCE	CLOSING: TV announcement	Have reopening announced on local TV station

---



---

## 9 Appendix D—Water Body Codes

This Appendix provides a separate table to explain the acceptable water body codes for name and type.

**Exhibit 9-1 Water Body Name**

<b>Code</b>	<b>Description</b>
ATLANTIC	Atlantic Ocean
PACIFIC	Pacific Ocean
GULF_MEXICO	Gulf of Mexico
LAKE_SUPR	Lake Superior
LAKE_MCHGN	Lake Michigan
LAKE_HURON	Lake Huron
LAKE_ERIE	Lake Erie
LAKE_ONTR	Lake Ontario
INLAND	Inland

**Exhibit 9-2 Water Body Type**

<b>Code</b>	<b>Description</b>
OPEN_COAST	Open Coast
SND_BY_INLT	Sound, Bay, or Inlet
STILL_WATER	Still Water
FLOW_WATER	Flowing Water

---

## 10 Appendix E—Horizontal Collection

This appendix provides a list of valid domain values for Horizontal Collection Method Name and Horizontal Collection Reference Datum Name.

### Exhibit 10-1 Horizontal Collection Method Name

Address Matching-House Number
Address Matching-Block Face
Address Matching-Street Centerline
Address Matching-Nearest Intersection
Address Matching-Primary Name
Address Matching-Digitized
Address Matching-Other
Census Block-1990-Centroid
Census Block/Group-1990-Centroid
Census Block/Tract-1990-Centroid
Census-Other
GPS Carrier Phase Static Relative Position
GPS Carrier Phase Kinematic Relative Position
GPS Code (Pseudo Range) Differential
GPS Code (Pseudo Range) Precise Position
GPS Code (Pseudo Range) Standard Position (SA Off)
GPS Code (Pseudo Range) Standard Position (SA On)
Interpolation-Map
Interpolation-Photo
Interpolation-Satellite
Interpolation-Other
Loran C
Public Land Survey-Quarter Section
Public Land Survey-Section
Classical Surveying Techniques
Zip Code-Centroid
Unknown
GPS-Unspecified
GPS, With Canadian Active Control System
Interpolation-Digital Map Srce (Tiger)
Interpolation-Spot
Interpolation-MSS
Interpolation-TM
Public Land Survey-Eighth Section

---

---

Public Land Survey-Sixteenth Section

Public Land Survey-Footing

Zip+4 Centroid

Zip+2 Centroid

---

**Exhibit 10-2 Horizontal Collection Reference Datum Name**

---

NAD27

NAD83

OTHER

UNKWN

AMSMA

ASTRO

GUAM

JHNSN

OLDHI

PR

SGEOR

SLAWR

SPAUL

WAKE

WGS72

WGS84

---

---

## 11 Appendix F—Addition Notifications

One feature of the notification schema is that users can submit activities over time as they happen, rather than being forced to submit them all at once. The primary Notification XML element is comprised of three main sub-elements:

- OrganizationDetail, containing information related to the organizations involved in the Beach Act Grant Program.
- BeachDetail, containing information related to the beaches overseen by the National Beach Program.
- BeachProcedureDetail, contains information related to the procedures used by beaches for Monitoring, Notification, issuance, and reopening.

An XML document containing additional activities needs only contain a portion of the BeachDetail element.

The BeachDetail element contains information on specific beaches, including the BeachId, name data, attribute data, activity data, and role data. During the initial submission (or initial submission for a given beach), all required information in the BeachDetail element must be included. During subsequent submissions (to add activities to specific beaches) only the activity data should be included\*. This activity data falls under the BeachDetail sub-element, BeachActivityDetail.

Exhibit 11-1 is an example Notification XML document containing two activities for the beach TX259473. Note that additional activities for TX259473 would be added by inserting additional BeachActivityDetail elements to the existing BeachDetail element. Activities on additional beaches would be added through the addition of BeachDetail elements.

### Exhibit 11-1 Example Notification XML Document

```
<BeachDataSubmission xsi:noNamespaceSchemaLocation="BeachesNotification.xsd"
xmlns:xsi="http://www.w3.org/2001/XMLSchema-instance">
  <BeachDetail>
    <BeachIdentifier>TX259473</BeachIdentifier>
    <BeachActivityDetail>
      <ActivityTypeCode>CONTAM_ADV</ActivityTypeCode>
      <ActivityName>Advisory</ActivityName>
      <ActivityActualStartDate>2003-12-23T09:27:00</ActivityActualStartDate>
      <ActivityActualStopDate>2003-12-23T09:27:00</ActivityActualStopDate>
      <ActivityReasonDetail>
        <ActivityReasonType>ELEV_BACT</ActivityReasonType>
        <ActivityReasonDescriptionText>1367 cfu</ActivityReasonDescriptionText>
      </ActivityReasonDetail>
      <ActivitySourceDetail>
        <ActivitySourceType>UNKNOWN</ActivitySourceType>
      </ActivitySourceDetail>
      <ActivityIndicatorDetail>
        <ActivityIndicatorType>ENTERO</ActivityIndicatorType>
      </ActivityIndicatorDetail>
    <ActivityMonitoringStationIdentifier>21TXBCH|NUE030</ActivityMonitoringStationIdentifier>
  </BeachActivityDetail>
  <BeachActivityDetail>
    <ActivityTypeCode>CONTAM_ADV</ActivityTypeCode>
    <ActivityName>Advisory</ActivityName>
    <ActivityActualStartDate>2003-11-14T16:10:00</ActivityActualStartDate>
    <ActivityActualStopDate>2003-11-14T04:10:00</ActivityActualStopDate>
```

---

\* Beach Name data can be updated in the subsequent Notification XML submissions. This is accomplished through the inclusion of the BeachNameDetail element (see the Beach Notification User's Guide, pages 3-13 to 3-15, 5-4).

```

<ActivityReasonDetail>
  <ActivityReasonType>ELEV_BACT</ActivityReasonType>
  <ActivityReasonDescriptionText>119 cfu</ActivityReasonDescriptionText>
</ActivityReasonDetail>
<ActivitySourceDetail>
  <ActivitySourceType>UNKNOWN</ActivitySourceType>
</ActivitySourceDetail>
<ActivityIndicatorDetail>
  <ActivityIndicatorType>ENTERO</ActivityIndicatorType>
</ActivityIndicatorDetail>
<ActivityMonitoringStationIdentifier>21TXBCH|NUE034</ActivityMonitoringStationIdentifier>
  </BeachActivityDetail>
</BeachDetail>
</BeachDataSubmission>

```

Previously, users of the PRAWN Notification Access database were unable to generate valid XML files for these additional, interim submissions. With the addition of the Custom XML Generation macro, users now have more control over which data to include in individual submissions.

### Exhibit 11-2 Custom XML Generation

The screenshot shows the 'XML Generation' dialog box. It has two calendar pickers: 'Activity Start Date' (Jan 2008) and 'Activity Stop Date' (Sep 2008). Below these are several checkboxes for data inclusion: 'Include Beach Data?' (checked), 'Include Beach Name Data?' (checked), 'Include Beach Attributes?' (checked), 'Include Beach Activities?' (checked), 'Include Beach Role Data?' (checked), 'Include Beach Coordinate Data?' (checked), 'Include Org./Person Data?' (checked), 'Include Procedure Data?' (checked), 'Include Completion Data?' (checked), 'Notification Data Submitted?' (checked), 'Monitoring Data Submitted?' (checked), and 'Location Data Submitted?' (checked). There is also a 'Year' field set to 2008. At the bottom, there is a 'File Name/Path?' field, a 'Browse...' button, and 'Go!' and 'Reset' buttons.

This form allows a user to choose which of the three main data sub-elements to submit, as well as which sections of the BeachDetail element (Names, Attributes, Activities, and Roles) should be included. The calendars allow a user to narrow down the Activities to a specific timeframe. If the BeachActivityDetail element is not included in a submission, the calendars become inactive.

To generate a custom file, simply follow these steps:

1. Open the Notification Access Database.
2. From the 'Macros' window, select the 'Custom XML Generation' macro.

- 
3. Once the Custom XML Generation macro is started, a screen (**Error! Reference source not found.**) will be presented.
  4. Select which data should be included in the Notification XML submission by checking or un-checking the boxes in the center of the windows.
    - a. Note that the calendars allow for the selection of activities within a specific date range. If activities are not included in a given submission, these calendars will be inactive.
  5. Click the “Browse...” button to select a name and location for the Notification XML submission.
  6. Once the selections have been made, click the “Go!” button to generate a Notification XML submission with the selected data.
  7. A message will display with details of the file generation, along with confirmation that the Notification XML submission was generated successfully.

A note on activity submissions:

- Because it is possible for multiple activities to overlap on portions of the same beach, it is not possible to determine if duplicate activities have been submitted. For this reason, it is ***critically important*** that State users track those activities that have been previously submitted; submitting an activity twice *will* result in a duplicate activity in PRAWN. Should an activity be submitted multiple times, please contact the EPA Beach program manager to correct the error.

## 12 Appendix G—Pollution Source Identification

This appendix provides logical tables of how to enter data concerning pollution sources for both the Access database and XML schema.

NOTE: All references to “pollution sources” are only “POSSIBLE sources” – see Page 24 of User Guide.

Notification Access Database (Revised to avoid double negatives in Schema’s Boolean logic, will be translated back to schema in XML)

**Exhibit 12-1 Access Database**

	BEACH_ATTRIBUTE		(Beach – all activities)	(Activity specific)
Example Case	[POLLUTION_SOURCES] Is it possible that there are pollution sources for the beach? Y/N	[POLLUTION_SOURCES_INVESTIGATED] Have the pollution sources been investigated for the beach? Y/N	BEACH_POLLUTION  [POLLUTION_SOURCE]	BEACH_ACTIVITY_REASON
1a. No Activity - No Investigation Done.  “May or may not be sources”	[Y]  Because no investigation was done the schema uses “Y” in this case to indicate that there may be sources, but they are unknown	[N]  It is unknown whether or not pollution sources exist for this beach because they were not investigated - no pollution sources are to be listed in the [BEACH_POLLUTION] table.	Leave Blank	Leave Blank
1b. No Activity – Investigation Done – No Sources Identified (Rare)	[N]  Investigated, but no sources found (rare)  “N” will make the schema force a “Y” into [POLLUTION_SOURCES_INVESTIGATED]	[Y]  If no pollution sources were found, i.e.: POLLUTION_SOURCES] = [N]  The schema is set to assume that the pollution sources were investigated.	Leave Blank	Leave Blank
1c. No Activity – Investigation Done – Sources Identified	[Y]  Investigated and sources found	[Y]  It is known that pollution sources exist for this beach because they were investigated and listed in the [BEACH_POLLUTION] table	List all identified for that beach, even though no activity that year	Leave Blank
2a. Activity Reported - No Investigation Done.	[Y]  Because no investigation was done the schema uses “Y” in	[N]  It is unknown whether or not pollution sources exist for this	Leave Blank	‘UNKNOWN’

---

“May or may not be sources”	this case to indicate that there may be sources, but it is unknown	beach because they were not investigated and no pollution sources were listed in the [BEACH_POLLUTION] table.		
2b. Activity Reported – Investigation Done – Sources Unidentified  “May or may not be sources”	[Y]  Because there were no sources found, the schema uses “Y” in this case to indicate that there may be sources, but they are unknown.	[Y]  It is known that pollution sources exist for this beach because there was an activity. However, although there was an investigation, the sources were not identifiable at the time of the investigation.	‘UNKNOWN’	‘UNKNOWN’
2c. Activity Reported – Investigation Done – Sources Identified	[Y]  Investigated and sources found	[Y]  It is known that pollution sources exist for this beach because they were investigated and listed in the [BEACH_POLLUTION] table	List all identified for all activities at that beach	List all identified for that activity



XML Schema (Boolean Logic with Double Negatives)

**Exhibit 12-2 XML Schema**

Example Case	Beach Attribute	Beach Pollution	Beach Activity Reason
1a. No Activity - No Investigation Done.  “May or may not be sources”	NoPollutionSourcesIndicator = ‘false’ PollutionSourcesUninvestigatedIndicator = ‘true’ if no investigation done	Leave Blank	Leave Blank
1b. No Activity – Investigation Done – No Sources Identified (Rare)	NoPollutionSourcesIndicator = ‘true’ investigated but no sources found	Leave Blank	Leave Blank
1c. No Activity – Investigation Done – Sources Identified	NoPollutionSourcesIndicator = ‘false’ investigated and sources found PollutionSourcesUninvestigatedIndicator = ‘false’ investigation done	BeachPollutionSourceCode = list all identified for that beach, even though no activity that year	Leave Blank
2a. Activity Reported - No Investigation Done.  “May or may not be sources”	NoPollutionSourcesIndicator = ‘false’ PollutionSourcesUninvestigatedIndicator = ‘true’ if no investigation done	Leave Blank	ActivityReasonType = ‘UNKNOWN’
2b. Activity Reported – Investigation Done – Sources Unidentified  “May or may not be sources”	NoPollutionSourcesIndicator = ‘false’ investigated and sources found PollutionSourcesUninvestigatedIndicator = ‘false’ investigation done	BeachPollutionSourceCode = ‘UNKNOWN’	ActivityReasonType = ‘UNKNOWN’
2c. Activity Reported – Investigation Done – Sources Identified	NoPollutionSourcesIndicator = ‘false’ investigated and sources found PollutionSourcesUninvestigatedIndicator = ‘false’ investigation done	BeachPollutionSourceCode = list all identified for all activities at that beach	ActivityReasonType = List All Identified for that activity

---

## 13 Appendix H—Data Entry Forms

Forms have been added to ease the data entry process; however, it is still possible to copy and paste records directly into the tables. To access the data entry forms, click the Forms tab.

**Exhibit 13-1 Forms**

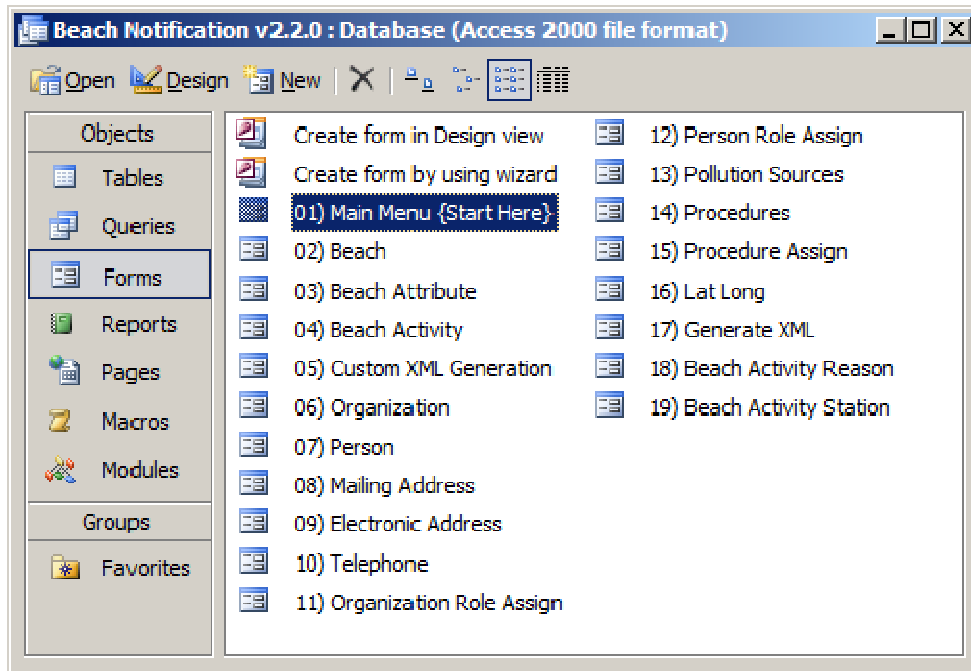

The main menu lists forms in the order of entry. For example organization data should be entered before beach data.

Exhibit 13-2 Main Menu

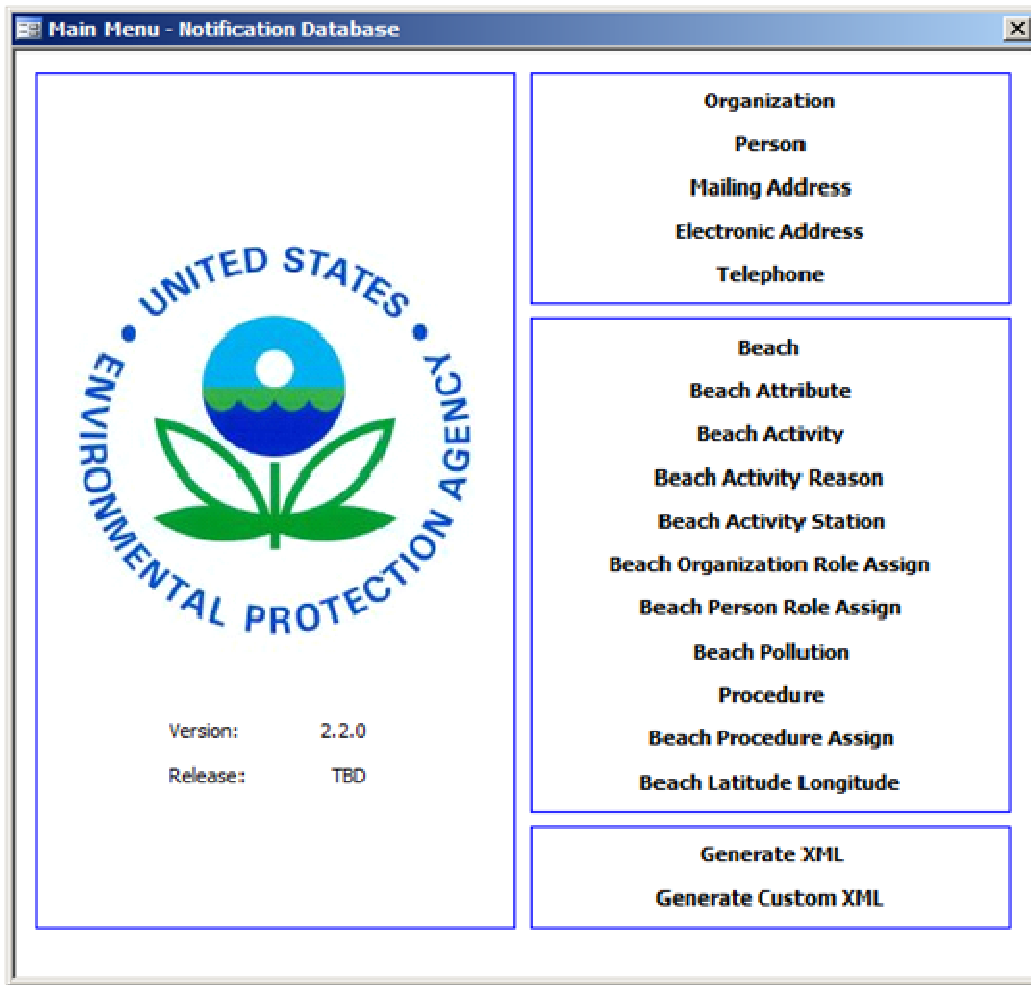

On each data entry form there is a Return to Main Menu button. Use this button to navigate back to the Main Menu form.

### Exhibit 13-3 Return to Main Menu

**Beach Data Entry Form**

<b>Beach ID</b>	MP142032
<b>Name</b>	CHALAN PIAO BEACH
<b>Description</b>	CHALAN PIAO BEACH
<b>Comment</b>	PACIFIC
<b>State Code</b>	MP
<b>FIPS County Code</b>	69110
<b>Access Type</b>	PUB_PUB_ACC
<b>Access Comment</b>	
<b>Send to EPA</b>	Y

**Return to Main Menu**

\* **Data elements in bold are required.**  
\*\* **For further information please reference the user guide or contact ebeaches@cgifederal.com**  
[Click here for the user guide.](#)

Record: 1 of 22

---

## 14 Appendix I—Summary Reports

Summary Reports have been added to assist in the QA process. To access the summary reports, click the Reports tab.

**Exhibit 14-1 Reports**

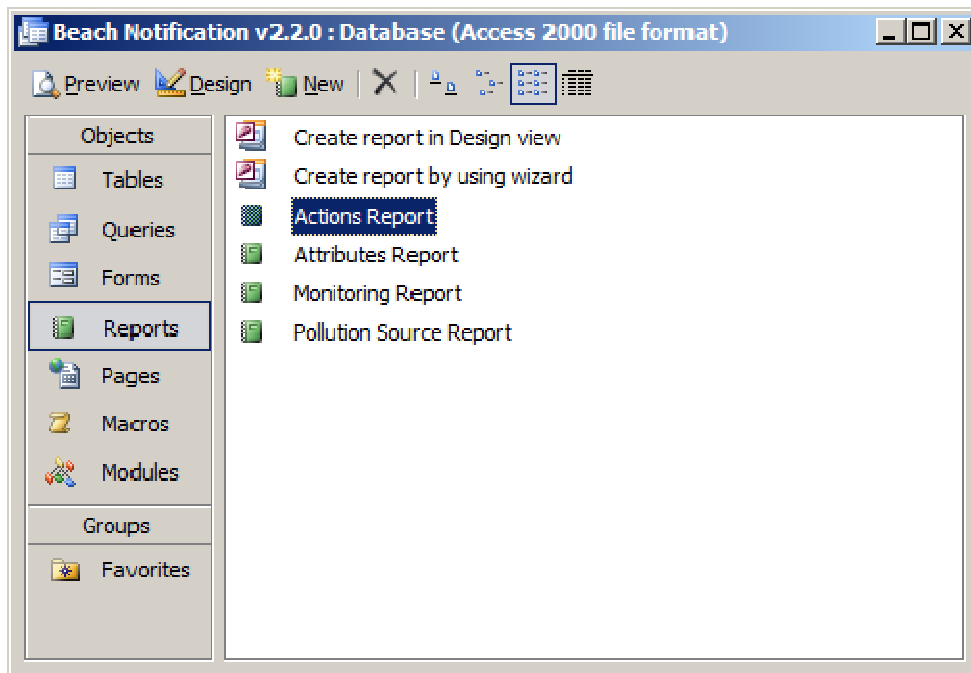

Exhibit 14-2 Actions

Actions

BEACH ID	BEACH NAME	ACTIVITY TYPE	ACTION START DATE/TIME	ACTION END DATE/TIME	ACTION DURATION (DAYS)	ACTION REASON	ACTION INDICATOR	ACTION SOURCE
MP142032	CHALANFIAO BEACH	CONTAM_ADV	1/14/2009 4:00:00 PM	1/16/2009 4:00:00 PM	2	ELEV_BACT	ENTERO	STORM
MP178931	TANARAG MEETING HALL	CONTAM_ADV	1/14/2009 4:00:00 PM	1/16/2009 4:00:00 PM	2	ELEV_BACT	ENTERO	STORM
MP198197	DPW CHANNEL BRIDGE	CONTAM_ADV	1/14/2009 4:00:00 PM	1/16/2009 4:00:00 PM	2	ELEV_BACT	ENTERO	STORM
MP198197	DPW CHANNEL BRIDGE	CONTAM_ADV	1/7/2009 4:00:00 PM	1/9/2009 4:00:00 PM	2	ELEV_BACT	ENTERO	STORM
MP198197	DPW CHANNEL BRIDGE	CONTAM_ADV	1/21/2009 4:00:00 PM	1/23/2009 4:00:00 PM	2	ELEV_BACT	ENTERO	STORM
MP198197	DPW CHANNEL BRIDGE	CONTAM_ADV	2/4/2009 4:00:00 PM	2/6/2009 4:00:00 PM	2	ELEV_BACT	ENTERO	STORM
MP198197	DPW CHANNEL BRIDGE	CONTAM_ADV	2/18/2009 4:00:00 PM	2/20/2009 4:00:00 PM	2	ELEV_BACT	ENTERO	STORM
MP198197	DPW CHANNEL BRIDGE	CONTAM_ADV	2/25/2009 4:00:00 PM	2/27/2009 4:00:00 PM	2	ELEV_BACT	ENTERO	STORM
MP198197	DPW CHANNEL BRIDGE	CONTAM_ADV	3/11/2009 4:00:00 PM	3/13/2009 4:00:00 PM	2	ELEV_BACT	ENTERO	STORM
MP198197	DPW CHANNEL BRIDGE	CONTAM_ADV	3/18/2009 4:00:00 PM	3/20/2009 4:00:00 PM	2	ELEV_BACT	ENTERO	STORM
MP227159	SOUTH LAULAUB BEACH	CONTAM_ADV	1/22/2009 4:00:00 PM	1/24/2009 4:00:00 PM	2	ELEV_BACT	ENTERO	STORM
MP234034	DAI-SCHIHOTEL BEACH	CONTAM_ADV	3/25/2009 4:00:00 PM	3/27/2009 4:00:00 PM	2	ELEV_BACT	ENTERO	STORM
MP272711	GARAPAN FISHING DOCK	CONTAM_ADV	1/21/2009 4:00:00 PM	1/23/2009 4:00:00 PM	2	ELEV_BACT	ENTERO	STORM
MP272711	GARAPAN FISHING DOCK	CONTAM_ADV	3/25/2009 4:00:00 PM	3/27/2009 4:00:00 PM	2	ELEV_BACT	ENTERO	STORM
MP272711	GARAPAN FISHING DOCK	CONTAM_ADV	2/4/2009 4:00:00 PM	2/6/2009 4:00:00 PM	2	ELEV_BACT	ENTERO	STORM
MP272711	GARAPAN FISHING DOCK	CONTAM_ADV	1/14/2009 4:00:00 PM	1/16/2009 4:00:00 PM	2	ELEV_BACT	ENTERO	STORM
MP272711	GARAPAN FISHING DOCK	CONTAM_ADV	1/7/2009 4:00:00 PM	1/9/2009 4:00:00 PM	2	ELEV_BACT	ENTERO	STORM

Exhibit 14-3 Attributes

Attributes

BEACH ID	BEACH NAME	BEACH ACT BEACH	BEACH OWNERSHIP ACCESSIBILITY	BEACH TIER RANK	START LATITUDE	START LONGITUDE	END LATITUDE	END LONGITUDE
MP142032	CHALANPIAO BEACH	YES	PUB_PUB_ACC	1	YES	YES	YES	YES
MP178951	TANAPAG MEETING HALL	YES	PUB_PUB_ACC	1	YES	YES	YES	YES
MP198597	DPW CHANNEL BRIDGE	YES	PUB_PUB_ACC	1	YES	YES	YES	YES
MP198597	DPW CHANNEL BRIDGE	YES	PUB_PUB_ACC	1	YES	YES	YES	YES
MP198597	DPW CHANNEL BRIDGE	YES	PUB_PUB_ACC	1	YES	YES	YES	YES
MP198597	DPW CHANNEL BRIDGE	YES	PUB_PUB_ACC	1	YES	YES	YES	YES
MP198597	DPW CHANNEL BRIDGE	YES	PUB_PUB_ACC	1	YES	YES	YES	YES
MP198597	DPW CHANNEL BRIDGE	YES	PUB_PUB_ACC	1	YES	YES	YES	YES
MP198597	DPW CHANNEL BRIDGE	YES	PUB_PUB_ACC	1	YES	YES	YES	YES
MP198597	DPW CHANNEL BRIDGE	YES	PUB_PUB_ACC	1	YES	YES	YES	YES
MP227159	SOUTH LAULAUB BEACH	YES	PUB_PUB_ACC	1	YES	YES	YES	YES
MP234034	DAI-ICHI HOTEL BEACH	YES	PUB_PUB_ACC	1	YES	YES	YES	YES
MP272711	GARAPAN FISHING DOCK	YES	PUB_PUB_ACC	1	YES	YES	YES	YES
MP272711	GARAPAN FISHING DOCK	YES	PUB_PUB_ACC	1	YES	YES	YES	YES
MP272711	GARAPAN FISHING DOCK	YES	PUB_PUB_ACC	1	YES	YES	YES	YES
MP272711	GARAPAN FISHING DOCK	YES	PUB_PUB_ACC	1	YES	YES	YES	YES
MP272711	GARAPAN FISHING DOCK	YES	PUB_PUB_ACC	1	YES	YES	YES	YES

## Exhibit 14-4 Monitoring

# Monitoring

BEACH ID	BEACH NAME	SWIM SEASON LENGTH	SWIM SEASON UNITS	SWIM MONITOR FREQ	SWIM SEASON MONITOR FREQ UNITS	OFF MONITOR FREQ	OFF SEASON MONITOR FREQ UNITS
MP142032	CHALANPIAO BEACH	12	MONTHS	1	PER_WEEK	0	PER_WEEK
MP178951	TANAPAGMEETING HALL	12	MONTHS	1	PER_WEEK	0	PER_WEEK
MP198597	DPW CHANNEL BRIDGE	12	MONTHS	1	PER_WEEK	0	PER_WEEK
MP227159	SOUTHLAULAU BEACH	12	MONTHS	1	PER_WEEK	0	PER_WEEK
MP234034	DAI-ICHIHOTEL BEACH	12	MONTHS	1	PER_WEEK	0	PER_WEEK
MP272711	GARAPAN FISHING DOCK	12	MONTHS	1	PER_WEEK	0	PER_WEEK
MP274563	STRICT #2 S TORM DRADNA	12	MONTHS	1	PER_WEEK	0	PER_WEEK
MP283265	ILAMOND HOTEL	12	MONTHS	1	PER_WEEK	0	PER_WEEK
MP412521	CBYAN	12	MONTHS	1	PER_WEEK	0	PER_WEEK
MP423664	SAMOANHOUSING AREA	12	MONTHS	1	PER_WEEK	0	PER_WEEK
MP425195	SAN JOSE BEACH	12	MONTHS	1	PER_WEEK	0	PER_WEEK
MP453911	UNAI DANGKULO BEACH	12	MONTHS	1	PER_WEEK	0	PER_WEEK
MP469801	DRAINAGE #2	12	MONTHS	1	PER_WEEK	0	PER_WEEK
MP555804	CENTRAL REPAIR SHOP	12	MONTHS	1	PER_WEEK	0	PER_WEEK
MP633629	NIKKO HOTEL	12	MONTHS	1	PER_WEEK	0	PER_WEEK
MP706463	NORTH LAULAU BEACH	12	MONTHS	1	PER_WEEK	0	PER_WEEK
MP743331	MANAGAHA BEACHES	12	MONTHS	1	PER_WEEK	0	PER_WEEK



The pollution source report takes up twice as many pages due to the number of columns it displays. Exhibit 14-6 displays the other half of the report.

### Exhibit 14-5 Pollution Source

## Pollution Source

BEACH ID	BEACH NAME	POLL. SOURCES INVESTIGATED?	POLL. SOURCES?	RUNOFF	STORM	AGRICULTURAL	BOAT	CAFO	CSO	SSO	POTW
MP142032	CHALANPIAO BEACH	NO	YES	NO	NO	NO	NO	NO	NO	NO	NO
MP178951	TANAPAG MEETING HALL	NO	YES	NO	NO	NO	NO	NO	NO	NO	NO
MP198597	DPW CHANNEL BRIDGE	NO	YES	NO	NO	NO	NO	NO	NO	NO	NO
MP217159	SOUTHLAULAUB BEACH	NO	YES	NO	NO	NO	NO	NO	NO	NO	NO
MP234034	DAI-ICHI HOTEL BEACH	NO	YES	NO	NO	NO	NO	NO	NO	NO	NO
MP272711	GARAPAN FISHING DOCK	NO	YES	NO	NO	NO	NO	NO	NO	NO	NO
MP274563	TRICT #2 STORM DRAIN	NO	YES	NO	NO	NO	NO	NO	NO	NO	NO
MP283265	DIAMOND HOTEL	NO	YES	NO	NO	NO	NO	NO	NO	NO	NO
MP412521	CEYAN	NO	YES	NO	NO	NO	NO	NO	NO	NO	NO
MP423664	SAMOAN HOUSING AREA	NO	YES	NO	NO	NO	NO	NO	NO	NO	NO
MP425195	SAN JOSE BEACH	NO	YES	NO	NO	NO	NO	NO	NO	NO	NO
MP453911	UNAI DANGKULO BEACH	NO	YES	NO	NO	NO	NO	NO	NO	NO	NO
MP469801	DRAINAGE #2	NO	YES	NO	NO	NO	NO	NO	NO	NO	NO
MP555804	CENTRAL REPAIR SHOP	NO	YES	NO	NO	NO	NO	NO	NO	NO	NO
MP633629	NIKKO HOTEL	NO	YES	NO	NO	NO	NO	NO	NO	NO	NO

Exhibit 14-6 Pollution Source (cont.)

BEACH ID	BEACH NAME	POLL. SOURCES INVESTIGATED?	POLL. SOURCES?	SEWER LINE	SEPTIC	WILDLIFE	OTHER	UNKNOWN
MP142032	CHALAN PIAOB BEACH	NO	YES	NO	NO	NO	NO	YES
MP178951	IANAPAG MEETING HALL	NO	YES	NO	NO	NO	NO	YES
MP198597	DFW CHANNEL BRIDGE	NO	YES	NO	NO	NO	NO	YES
MP227159	SOUTH LAULAU BEACH	NO	YES	NO	NO	NO	NO	YES
MP234034	DAI-ICHI HOTEL BEACH	NO	YES	NO	NO	NO	NO	YES
MP272711	GARAPAN FISHING DOCK	NO	YES	NO	NO	NO	NO	YES
MP274563	TRETT #2 STORM DRAIN	NO	YES	NO	NO	NO	NO	YES
MP283265	DIAMOND HOTEL	NO	YES	NO	NO	NO	NO	YES
MP412521	OBYAN	NO	YES	NO	NO	NO	NO	YES
MP423664	SAMOAN HOUSING AREA	NO	YES	NO	NO	NO	NO	YES
MP425195	SAN JOSE BEACH	NO	YES	NO	NO	NO	NO	YES
MP453911	UNAI DANGKULO BEACH	NO	YES	NO	NO	NO	NO	YES
MP469801	DRAINAGE #2	NO	YES	NO	NO	NO	NO	YES
MP555804	CENTRAL REPAIR SHOP	NO	YES	NO	NO	NO	NO	YES

## 15 Appendix J—CDX Messages

The first email will notify the user that CDX has received their submission. It will also notify them to expect two additional emails from PRAWN.

Exhibit 15-1 Your CDX eBeaches Data Submission

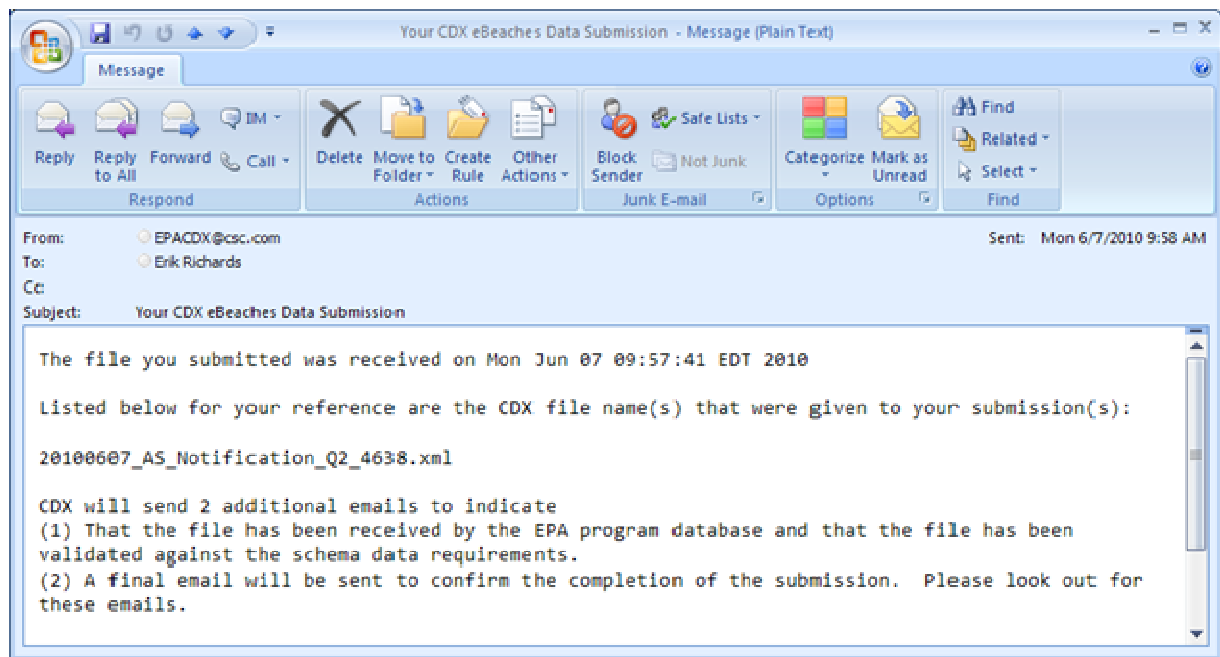

The second email will notify the user whether their XML validated against the schema. A list of errors will be provided if the XML does not validate according to the schema.

## Exhibit 15-2 Validation Message

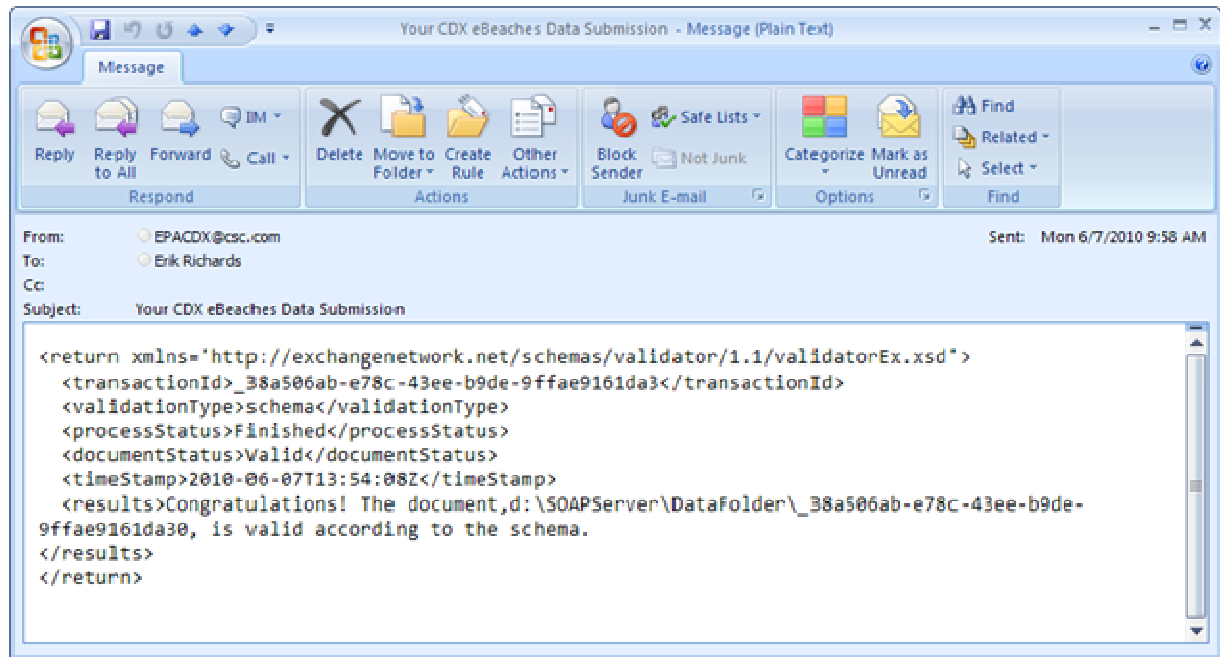

The final email will notify the user of any data errors/warnings they may need to correct within the submission.

## Exhibit 15-3 Final Email

