APPENDIX A: SMART GROWTH IMPLEMENTATION ASSISTANCE VISIT

Background on SGIA

Communities around the country are interested in fostering economic growth, protecting environmental resources, and planning for development, but they may lack the tools, resources or information to achieve these goals. In response to this demand, the Development, Community, and Environment Division of the USEPA, launched the Smart Growth Implementation Assistance Program. This is a competitive program to provide technical assistance—through contractor services—to selected communities. This assistance is expected to improve the overall climate for infill, brownfields redevelopment, and the revitalization of non-brownfield sites—as well as deliver on other community and environmental goals.

The City of Spokane was one of four communities selected to participate in the SGIA program in 2006. The city and its local partners asked EPA to help with the following tasks:

- Develop an understanding of the Spokane market and potential for urban redevelopment in the University District; and
- Identify strategies that the public and private sectors can use to create a strong neighborhood and increase development opportunities in the University District.

After receiving this charge from the city, EPA worked with its contractor, ICF International, to assemble a team of national smart growth experts to assist the city. The Team visited Spokane January 17-19, 2007. Site visit activities included a two-day public design workshop, meetings with university and city leadership, and a final public presentation of the team's findings. The workshop and presentation were open to the public and included a wide variety of participants including area residents, property owners, the business community, city and university leadership, local developers, and brokers. Based on their experiences in other parts of the country, this Team provided Spokane with options and strategies for consideration that could support development objectives for the University District.

Project Sponsor

City of Spokane Department of Economic Development

Local Team Members

Teresa Brum
City of Spokane

Bruce Butterworth
East Sprague Business Association

Marty Dickenson
Downtown Spokane Partnership

Cody George
City of Spokane

Brian Jennings
City of Spokane

Patrick Jones
Eastern Washington University

Bob Scarfo
Washington State University

Dick Winchell
Eastern Washington University

Special Thanks

To Mayor Hession and the City Council for allowing the Team to use the City's excellent facilities, and for encouraging the exploration of new planning ideas for Spokane's University District.

Workshop Participants

Participants in the workshop and meetings represented a wide range of viewpoints and interests. We had participation from property owners, businesses, real estate professionals, interested citizens, city officials and staff and others. The participants listed have been consolidated from sign-in sheets that were circulated during the workshop and are included for reference purposes only. This list may not represent the full number of attendees. Individuals may not have seen the sign-in sheet at the workshop or they may have chosen not to sign in.

Melissa Ahern	Dave Clack	Dennis Hession
Bob Apple	Julia Clarke	Marie Hill
Rodolfo Arevelo	Fritz Clarke	Art Jenkins
Tom Arnold	Santos Covarrubias	Brian Jennings
Reah Beach	James Dalton	Scott Johnson
Grant Becherini	Larry Davis	Patrick Jones
Greg Belenky	Serina Dettwiler	Bill Kelley
Teresa Brum	Loren Dudley	Shannon Kelly
Rob Burnett	Dave Enos	Jim Kolva
Teresea Cameron	Roger Flint	Bob Lafferty
Lisa Capoccia	Al French	Dennis Leidall
Jami Cary	Cody George	Jamie Litzkow
Barbara Chamberlain	Earl Gibbons	Paul Lutey
Steve Cheung	Margie Hall	Bob Mackuz
Emily Christianson	Josh Hall	Dave Mandylke

Nancy McLaughlin
Patrick McSpadden
Joan Menzies
Doug Menzies
Julie Neff
Don Oliveri
Brian Pitcher
Barry Quinlan
Angela Raymond
Ron Reed

Dave Robinson
Mike Rhome
Richard Rush
Patricia Sampson
Brian Says
Andy Schenck
Larry Schmedding
Joe Shogan
Don Sims
Dave Sitton

Darrell Smith
Joel Smith
Brad Stark
Steve Trabun
Mary Ann Ulik
Len Urgeleit
Mary Verner
Amber Waldref
Mike Warpenburg
Dick Winchell

EPA/ICF Consulting Team

Dena Belzer, Principal

Strategic Economics

Ms. Belzer specializes in connecting regional economic and demographic growth trends to real estate development activity and local policy initiatives. Ms. Belzer's work draws upon a traditional urban economics framework and innovative analytical techniques to provide strategies for addressing growth and development-related issues. Ms. Belzer is an expert on transit oriented development, fostering mixed-use districts, and local-serving retail attraction. She has helped to establish best practices for transit oriented development in multiple communities as well as writing extensively on the topic.

Jim Charlier, President

Charlier Associates, Inc.

Mr. Charlier is a nationally recognized transportation planning professional with 31 years experience in local, regional and statewide settings across the country. He has provided transportation planning services to clients throughout the United States and is a frequent speaker, lecturer and facilitator on urban transportation planning challenges and opportunities. Mr. Charlier obtained BS and MS degrees from Iowa State University in 1972 and 1975 and is a certified planner (AICP).

Melissa Edwards, Associate

Strategic Economics

Ms. Edwards specializes in regional analysis, financial feasibility and market analysis. Ms. Edwards received her Masters in City and Regional Planning with a concentration in local and regional economic development from the University of California, Berkeley in 2004.

Tim Van Meter, Architect/Partner

Van Meter Williams Pollack

Mr. Van Meter's experience has ranged widely from buildings, to landscape designs, to urban designs for districts and neighborhoods. As a partner in Van Meter Williams Pollack, Tim has focused on mixed use developments, urban infill projects and affordable housing. He has led the design team on many of the firm's complex design projects, formulating the program, building consensus and developing design solutions. Projects include: affordable housing developments; industrial reuse plans; and mixed use projects.

Rick Williams, Architect/Planner

Van Meter Williams Pollack

Mr. Williams' work has been on the forefront of mixed use pedestrian and transit-oriented planning and urban design. The scale of projects range from residential developments, mixed-use neighborhoods and urban infill to community plans and new town proposals. As a partner in Van Meter Williams Pollack, Rick brings his diverse background and extensive experience to focus on planning and urban design projects involving mixed use, pedestrian and transit oriented developments as well as project management and construction administration efforts for a variety of the firm's building projects. Projects Rick has been recently involved include the MacArthur Boulevard Streetscape Concept Plan; Millsmont Urban Design Plan, S.F. Transit Oriented Neighborhood Planning, Prescott /Acorn Neighborhood Transportation Plan, Westminster Traditional Neighborhood Design Guidelines, the Fremont CBD Plan, and the Fremont Small Lot Residential Design Guidelines.

William Schroer, Vice President, ICF International, managed the ICF consulting team.

EPA Representatives

Adhir Kackar and Matthew Dalbey, Development, Community and Environment Division

Schedule of Activities

Wednesday, January 17, 2006

8:30- 9:00 AM: Team meeting

9:00– 11:00 AM: Tour of the University District

11:30 AM – 1:00 PM: Lunch with local team

2:00 – 3:30 PM: Meeting with city officials and Mayor to discuss University District development objectives and project goals.

4:00 – 5:00 PM: Prepare for evening meeting

5:30 – 7:00 PM: Meeting with the community to identify University District development objectives and issues of concern to the public. (Open to the public)

Thursday, January 18, 2006

8:30- 9:00 AM: Team meeting at Rocket Coffeehouse

9:00 AM- 6:00 PM: All-day workshop to develop development options for the University District (open to the public)

9:30 – 11:30 PM: Meeting to discuss University District transportation issues with City engineering and public works, SRTC, and DKS Associates.

3:30 – 5:00 PM: Meeting to discuss campus development objectives and issues with Riverpoint campus institutions and city.

5:30 – 7:00 PM: Presentation of preliminary findings to the community

Friday, January 19, 2006

8:00 – 9:00 AM: Presentation of project findings to City Council

9:00 AM – 12:30 PM: Prepare for community presentation

1:00 – 3:00 PM: Presentation of project findings to Community (open to the public, broadcast on Channel Five)

3:30 – 5:00 PM: Presentation of project findings to city officials

APPENDIX B: UNIVERSITY DISTRICT MARKET ANALYSIS

University District, Market Analysis Spokane, Washington

June 18, 2007

Prepared for:
The City of Spokane Economic Development Department



INTRODUCTION

A market and economic analysis was completed for the City of Spokane to estimate the demand for housing and employment uses in the University District. The market and economic analysis will set the stage for developing a coherent vision and plan for the University District that will both take advantage of the market demand, and also allow greater economic development than would be possible without planning.

Setting the Context

The City of Spokane is located in Eastern Washington, approximately 20 miles from the Idaho Border. As the largest city in the region, Spokane is the largest employment center and is the area where many living in the region do their shopping. Over the past decade as vacant land available for office space began to dwindle in Spokane, cities outside of Spokane such as Spokane Valley and Liberty Lakes developed into job centers for service and technology jobs (Figure 1).

Figure 1: Spokane County



Source: Google Earth, 2007.

The University District, located just to the east of the downtown, houses three universities, Gonzaga University, Eastern Washington University and Washington State University (Figures 2 and 3). The district is divided into north and south by the Spokane River. The northern part of the district, where Gonzaga is located, is a distinctly separate housing and office market than the area to the south of the river.

Figure 2: University District Boundaries



Source: Google Earth, 2006

Figure 3: Central Spokane



Source: Google Earth, 2006

The southern part of the University District is further divided into four sub-areas (Figure 4). Washington State University is designated by state law as the institution with full power, authority, and responsibility to manage and operate the Riverpoint campus (located in Areas 1 and 2), which houses academic programs delivered by Washington State University and Eastern Washington University. Area 1, the northern most area between Spokane Falls Boulevard and the Spokane River, is mostly comprised of academic buildings. Area 2, the area between Spokane Falls Boulevard and the railroad tracks, is mainly owned by Washington State University, with some private ownership, particularly west of Pine Street. This area has many vacant properties, a valuable cache of historic buildings and a few university-related buildings such as the Sirti Technology Center and Washington State University Bookstore. Area 2 has the best immediate potential to capture residential and commercial development. Area 3, between the railroad tracks and Sprague Avenue contains mostly one to two-story commercial and light industrial uses built in the last 50 years. This area has potential in the medium term, approximately five to seven years, to capture residential and commercial development. The best opportunities for Area 4, south of Sprague Avenue and north of Interstate Highway 90, lie in capturing commercial development in the long-term. Short-term potential for this area is largely dependent on the extent to which hospitals south of I-90 will look to this area for expansion needs.

Figure 4: University District sub-areas

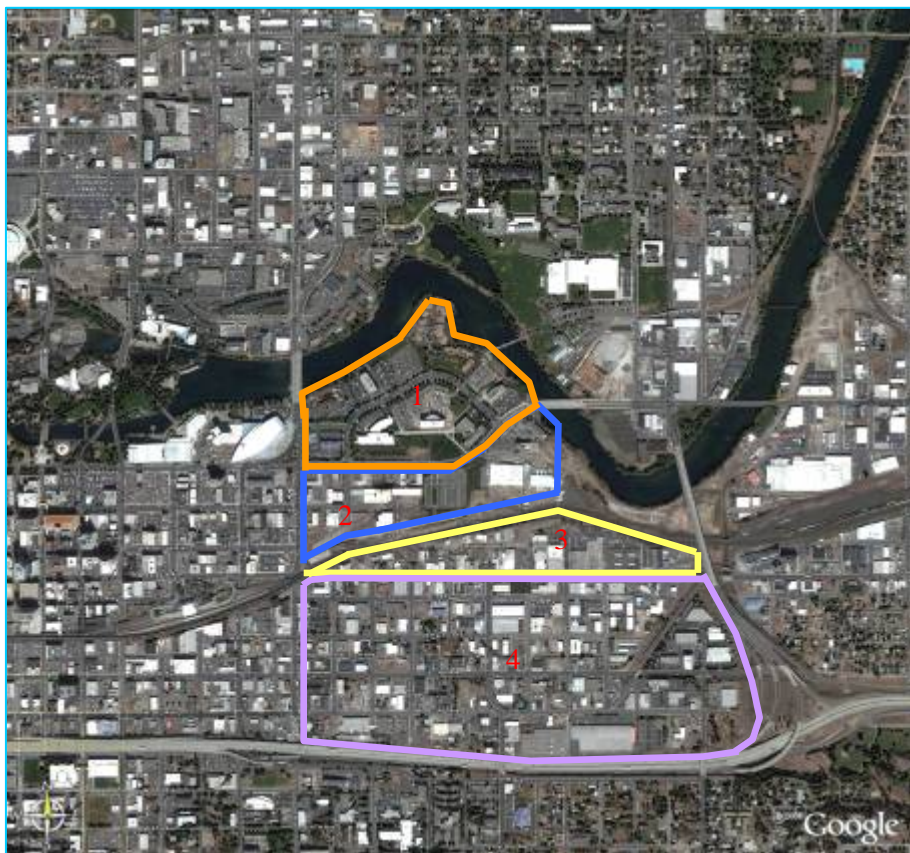

Source: Google Earth

ECONOMIC DRIVERS OF DEMAND

In 2005, the Spokane MSA comprised 259,515 jobs, up 13 percent (30,651 jobs) from 1995. This modest but steady growth is indicative of the Spokane economy over the last twenty-five years. During this time, the economy experienced significant changes as a result of decreases in the production sector, which includes manufacturing. For example, from 1999 to 2004, the production sector had a loss of –22 percent (4,378 jobs). In response, the economy demonstrated a marked shift to a knowledge- and service-based economy. In the period from 1999 to 2004, the services sector enjoyed an increase of 13 percent (7,255 jobs) and the knowledge sector demonstrated an increase of 13 percent (735 jobs). Indicative of the advancement of knowledge-based sectors are the increasing share of the professional, scientific, and technical services devoted to knowledge-based industries¹. In 1999, these industries comprised 18 percent of all professional, scientific and technical services (NAICS code 54) and in 2004 they made up 22 percent, or an increase in 478 jobs. While this growth suggests only a slight shift in the economy, other indicators suggest that it is a meaningful one. For example, despite an overall decrease in traditional manufacturing, the area is experiencing an increase in small, high-tech manufacturing operations. When these facts are coupled with the demonstrated strong growth in the health care sector, they are reflective of a significant economic trend.

Figure 5: Spokane Cluster Trends, 1999 - 2004

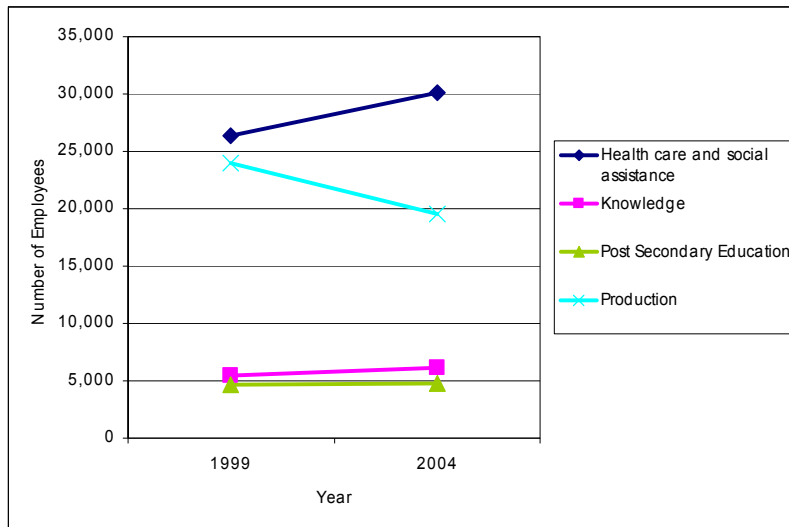

Source: *Strategic Economics, 2006; County Business Patterns, 1999, 2004*

¹ Comprised of NAICS codes: 5419 - Other professional, scientific, technical services; 5416 - Management, scientific and technical consulting; 5417- Scientific Research and Development.

Figure 6: Employment Trajectory 1999 to 2004

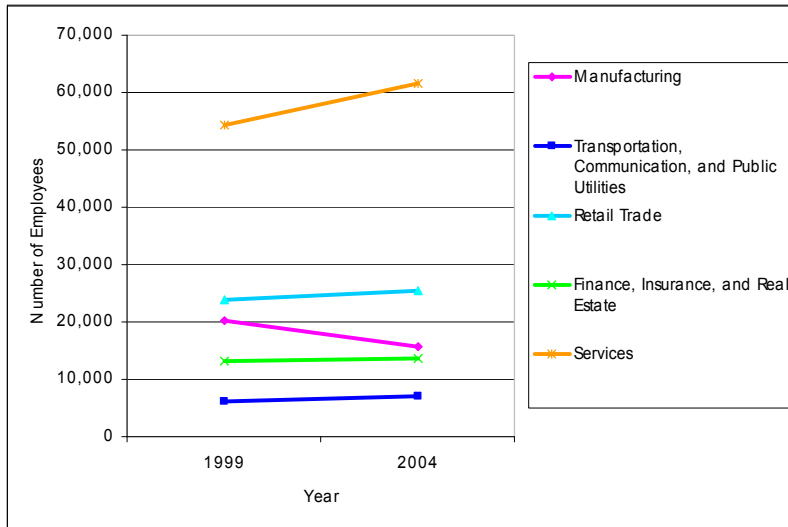

Source: Strategic Economics, 2006; County Business Patterns, 1999, 2004

Despite this change in the economy’s makeup, Spokane maintained its role in the region as a center for regional trade and state and local government jobs. Combined, these two sectors comprised 32 percent of Spokane’s economy in 2005 (retail trade comprised 17 percent and state and local government comprised 15 percent). Equally significant in the Spokane economy are the educational services, health care, and professional services sectors.

Figure 7: Spokane Industry Trends

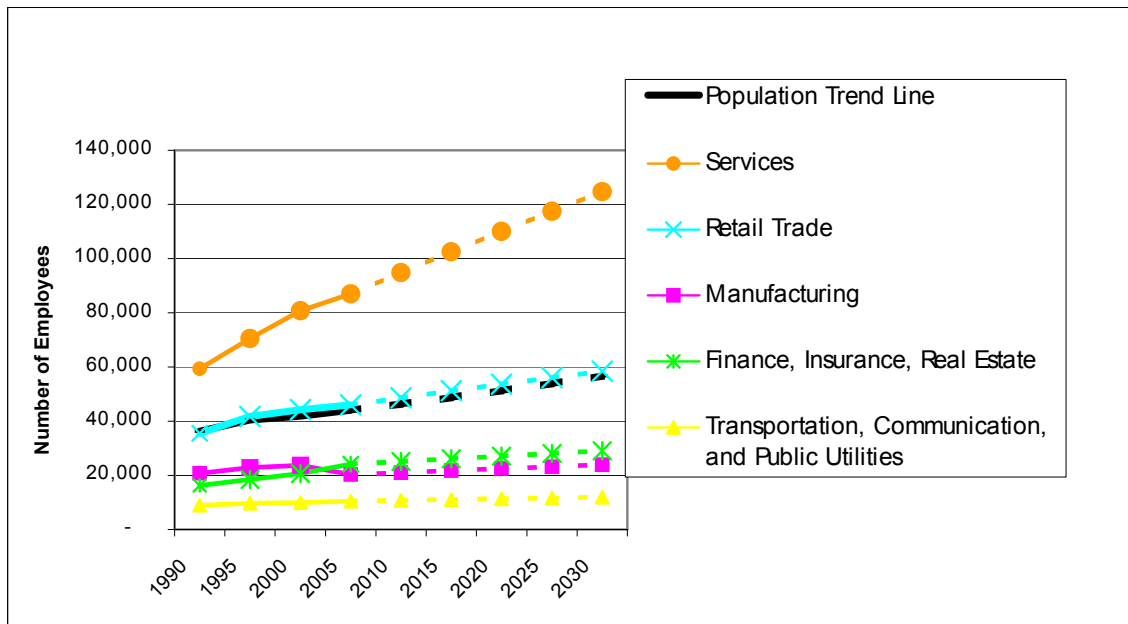

Source, Strategic Economics, Woods & Poole

While growth in educational services and professional services tracks fairly closely with the overall population growth of the region, growth in the health care and social assistance sector exceeds population growth and reflects Spokane's competitive advantage in these sectors. From 1999 to 2004, the health care sector experienced 39 percent growth (3,751 jobs). This accelerated growth is largely a result of the major institutions that call Spokane home (within this sector, Medical and Surgical Hospitals are, not surprisingly, historically the largest employers in Spokane). The influential presence of Deaconess and Valley Hospitals, Sacred Heart Hospital, Holy Family Hospital, Washington State University, Gonzaga University, and Eastern Washington University serve to catalyze biomedical and biotech startups within the region. Evidence of growth in these sectors can be seen in many physical developments in and around Spokane, such as, Sirti, Liberty Lake, Spokane Valley, Iron Bridge and the Inland Northwest Technology Park. Growth in the sector is also benefiting from Washington State's investment in educational sectors. For Spokane, legislative appropriations for the WWAMI (Washington, Wyoming, Alaska, Montana, Idaho) and RIDE (Regional Initiatives in Dental Education) programs (pending legislative approval in the 2007 session) will result in expanded medical and dental programs. WSU is also launching a doctoral degree in nursing and expanding its nursing enrollments.

Role of a University in the Local Economy and Economic Development

The importance of local universities to the Spokane economy is evident in the large number of jobs in education but it is important to also consider the economic role that universities play in local economies, beyond just their role as major employers, and distinct from large corporations. Universities tend to be more stable in a local economy than companies governed by stockholders interested primarily in revenue. For this reason, they do not merge or relocate with the same frequency as other companies. Additionally, because a university attracts students from a large area outside its home territory, it generates significant dollars from outside the region but typically spends the money locally within the region.

In Spokane, the universities serve this economic function and have also coalesced into a distinct neighborhood, the University District. Within this district lies the bedrock of a vibrant, dynamic area attractive to businesses working in tandem with the universities and hospitals. As part of our research, Strategic Economics conducted several telephone interviews with the companies and organizations that comprise this element of Spokane's new economy. These companies spoke about the synergies that exist between the hospitals and the business community. The presence of Sirti, a tech incubator and business support organization geared toward the development and growth of technology companies in Spokane, contributes to the collaborative and innovative spirit of the University District. As one economic development professional characterized it the University District, "is where higher ed and technology come together." Companies that we talked to expressed a predisposition toward locating in the University District. Some companies like the area because of the, "interaction between Riverpoint campus and the hospitals." Locating in the "hub of the action" is useful for companies for many other business reasons. Company representatives view the University District as a means of showing off Spokane. One said, "I like being in the hubbub and when you bring my companies (i.e. big pharma) it's kind of all there is to show off in the neighborhood, which I think shows off well...but if I were taking them to the Spokane Industrial Park, they don't really get a flavor...The University District shows very nicely...I put them up at downtown hotels and they can walk." Not only does the University District make a good impression for investors but locating there is also useful for collaboration with other researchers and colleagues. One entrepreneur said of Sirti, "People like the community feeling...people like to hang out and that's when you start dialoguing about ideas and that sort of thing." Finally, interviewees said that the location of Sirti in the University District aids in recruiting interns and new graduates from the universities. One person reported that proximity to universities is an especially critical issue for startups, who depend heavily on entry-level employees, because they can more easily recruit interns and new employees.

Despite voicing a clear desire to locate their business in the University District, several companies expressed frustration that the University District plan was happening slower than market forces and

therefore was impacting their business decisions. One reported that, “The whole U district thing is not moving fast enough. These companies, like startups that are growing fast, need to have things happen quickly.” And another said, “I was interested in being located in the U district for the technology side, we could have probably had some joint labs [with the hospital and universities]...We wanted to be one of the big parties down there to attract attention and we wanted it for our employees because we do think that in the long run that it’s going to be kind of a neat place to be.”

The competing building requirements of the universities and growing businesses also emerged as an area where the needs and strategic objectives of the businesses and the universities differ. One interviewee reported that, “...when you build at the university, they build it to last 100 years. There is a difference in terms of university construction...when you’re looking at costs, you’ve gotta look at cost of construction in what the university thinks they own. So they want to assert that they have the right to take it back and by the way, we built it to your specs so that you can put students in there 40 years from now even though it’s going to be in need of a functional update in 40 years but it still has marble columns and ceilings that are 40 feet high. Most businesses don’t do it that way because it is a business not an institution.”

All respondents expressed dissatisfaction that despite their desire to locate in the University District, there is a lack of adequate space in the Sirti buildings or in university or privately owned buildings in the University District for successful companies who need additional space. The space and facility needs of the biotech and biomedical businesses is very specific and according to the firms that we interviewed most of the properties that are in the University District are not currently configured to meet their facility needs. These firms mentioned that they would like support from the city or WSU Spokane to help them find space in the District that is configured, or can be configured to meet their needs.

An economic development professional told us that companies that outgrow Sirti are, “more than likely going to go to the traditional areas where companies aggregate, which would be Liberty Lake and the Spokane Valley Industrial Park or Inland Northwest Technology Park.” A Sirti business owner agreed, saying, “I think that as companies graduate from Sirti, they will be forced to go to the Valley or up north.” Another company’s representative who is looking for space within Spokane said, “There’s not a lot of inventory of buildings out there so I’ve had discussion about building a new building but I would prefer not to go that way.”

Conclusions about implications for market: future demand = here now!

Interviews of Spokane area business people and analysis of the economic data tell a common story that the biomedical and biotech sectors are genuine growth and opportunity sectors for Spokane. Along with this growth and development comes a need for research space. Depending on the type of company, this demand can take the form of wet labs, engineering prototype shops, bench space, dry labs, and other research facilities. When Strategic Economics talked with companies working in these areas, they unanimously expressed a desire to locate their business in the University District above all other areas. They saw value in locating in an area close to universities, hospitals, students and each other. However, despite this demonstrated demand, these companies have experienced difficulty actually identifying space that meets their needs in the University District. We spoke with companies were currently searching for space and could not find what they need in the University District. They expressed disappointment that that space hasn’t been made more readily available through Sirti and/or in collaboration with the university. Strategic Economics’ analysis of the potential for future demand for space in Sirti and the University District revealed that there is no need to wait for the future because demand exists today.

While this analysis finds that biomedical and biotech firms present a strategic niche for Spokane, it also concludes that this sector has not fully taken hold in the Spokane economy. The relatively small numbers of these businesses represented in the economic data supports this conclusion. It was further substantiated

by interviewees who reported that new tech businesses in Spokane are largely started by people already within Spokane or from Spokane and not by people from the outside relocating to Spokane because it offers them a competitive advantage. For that to happen, it is extremely important that decision-makers capitalize on what activity exists today by promoting agglomeration and concentration opportunities among existing companies. On a small- short-term-scale, Sirti fills this need. However, because demand today exceeds what is available at Sirti, it is important that efforts be made to meet the demand quickly. According to the firms that we interviewed, they will be more likely to move to tech parks on the periphery of the city, if they cannot find space in the University District. This could dilute the concentration of companies in any one place and work in opposition to efforts to further grow Spokane's biomedical and biotech sectors. Additionally, the provision of new private sector space should be balanced with the need to provide academic land and buildings that support the instructional and research mission of WSU Spokane and EWU. Continued growth of WSU and EWU is essential to the expansion of the biotech and biomedical sector. Finding land in the University District for both academic and non-academic uses is critical to maximize the synergies between the universities, technology and medical sectors.

DEMOGRAPHIC DRIVERS OF DEMAND

This section profiles demographic characteristics of Spokane and Spokane County and outlines their implications for market demand in the City of Spokane and the University District. Prior to the mid-1950s, the population growth rate of Spokane County and the City of Spokane were about the same. Following a nationwide trend, increasing levels of suburbanization caused Spokane County's growth rate to be much greater than the City of Spokane's growth rate (Figure 8). This trend has continued to fuel growth in the County even as the population of the City of Spokane has leveled off or even declined in certain decades. After a dip in population from the late 1960s through the mid-1980s, the population of Spokane has risen as downtown revitalization and demographic changes have fueled an increased interest in city living. Trends over the past six years show a modest increase in Spokane's population and housing units compared to more robust growth in the County.

Figure 8: Historical Population, 1900 - 2006

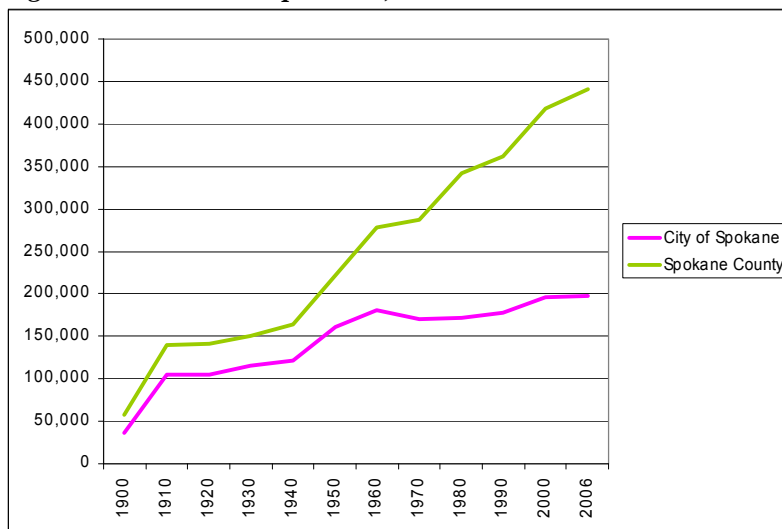

Source: Washington State Office of Financial Management, 2002; Claritas, 2006

Figure 9: Population, 1990 - 2006

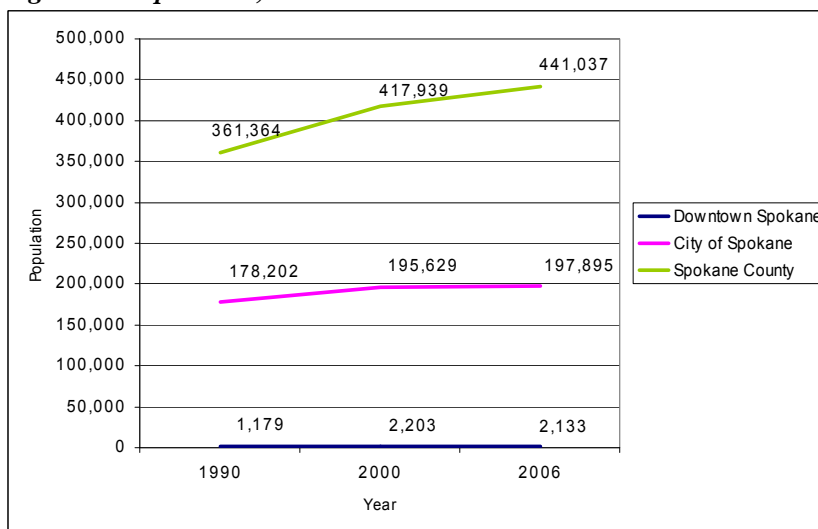

Source: U.S. Census 1990, 2000; Claritas, 2006

Figure 10: Housing Units, 1990 - 2006

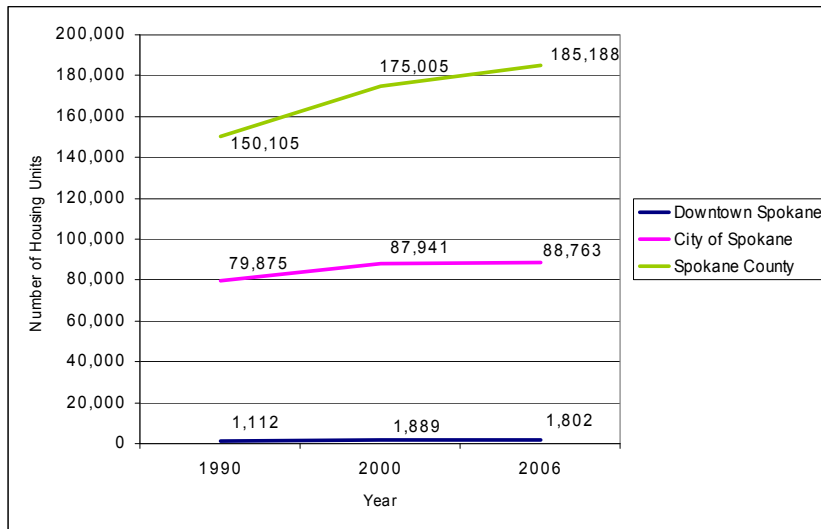

Source: U.S. Census 1990, 2000; Claritas, 2006

Today 197,895 people live in the City of Spokane while 441,037 people live in Spokane County (Figure 9). The population of downtown Spokane is 2,133. The City has 88,763 housing units compared to 1,802 in the downtown (Figure 10).

Today 197,895 people live in the City of Spokane while 441,037 people live in Spokane County. The population of downtown Spokane is 2,133 (Figure 11). The median income of Spokane is \$37,721, lower than the county median income of \$43,789. On average, buying power in the City will be lower than in the County. The age distribution of Spokane is approximately the same as the County with a large percentage of children under the age of 18 (Figure 12). This demographic makes up almost 25 percent of the population. There are also a large portion of people in the age groups that tend to desire downtown living; young professionals between 25 and 35 and Baby Boomers aged 43 to 61. This segment of the population makes up over 40 percent of the population of Spokane.

Figure 11: Current Demographics, 2006

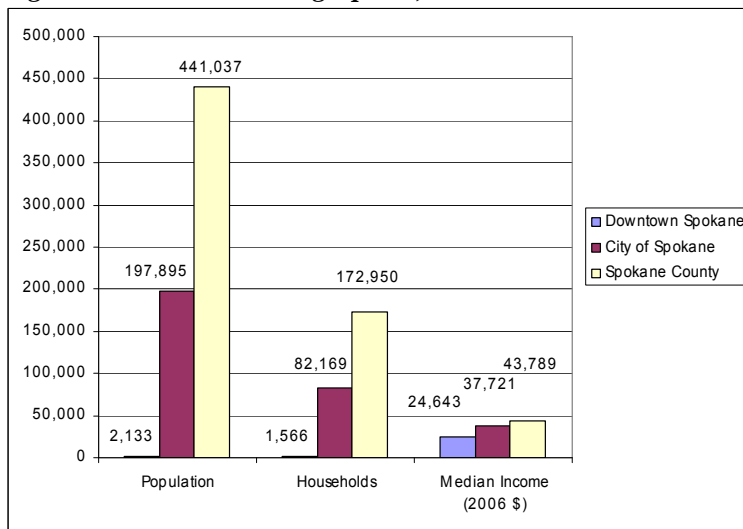

Source: Claritas, 2006

Figure 12: Age Distribution, 2006

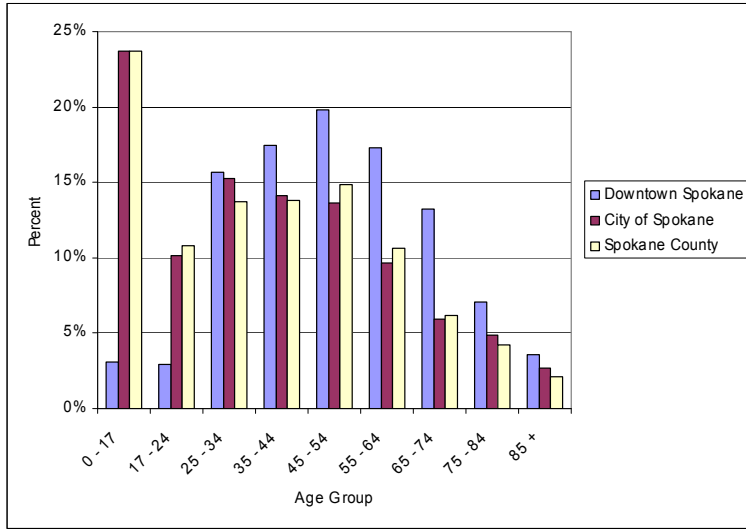

Source: Claritas, 2006

Income distribution and tenure are also similar between the City and the County with tenure being slightly higher in the County (Figures 13 and 14). Demographics for downtown Spokane show a concentration of low-income elderly who live in rental housing. Prior to the recent interest in downtown from other demographic groups, senior living facilities were clustered in downtown near hospital and social services. This distribution will become younger and wealthier given the types of buyers recently built projects are marketed to.

Figure 13: Income Distribution, 2006

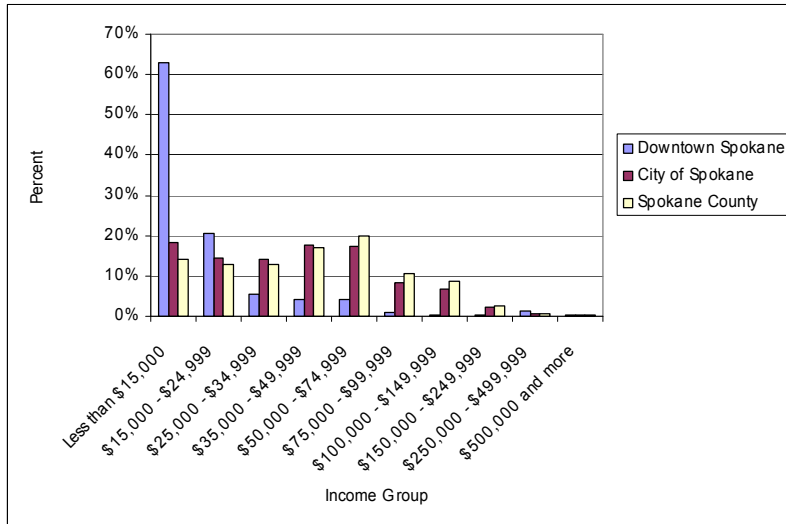

Source: Claritas, 2006

Figure 14: Housing Tenure, 2006

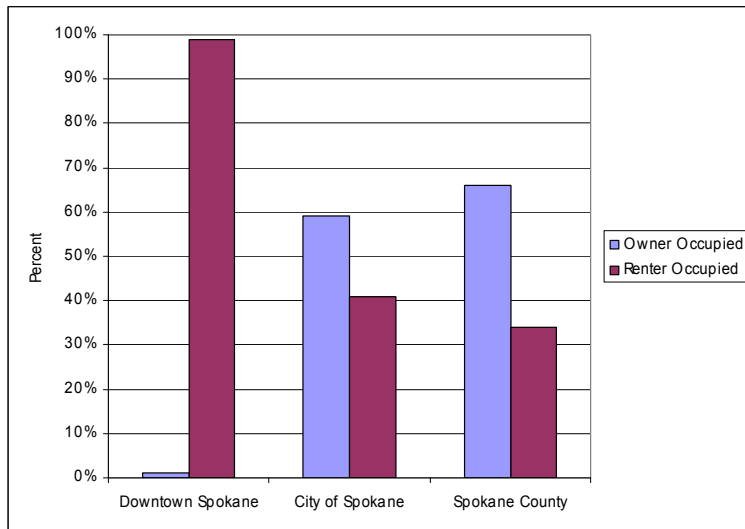

Source: Claritas, 2006

MARKET ANALYSIS

In the past five years, almost 600 housing units have been built in the downtown and the City has been permitting approximately 300 multifamily units per year for the last five years (Figure 15). Current market momentum is focused on the downtown and shows there is demand for denser product types. Figure 16 shows the location of major projects built in the downtown over the last five years. These projects have commanded high per square foot prices compared to other product types. The mid-range of the market for condominiums is between \$300,000 and \$500,000 but ranges from \$150,000 on the low end to \$500,000+ on the high end. There has been a healthy market for rehab which is transitioning into new buildings. Another much anticipated new project, Kendall Yards, will use the principals of Traditional Neighborhood Design (also called New Urbanism) and feature more dense housing types than are typically found outside of downtown Spokane. Market momentum is starting to shift beyond the CBD, including east towards the University District. The Western Soap Condos on Division and Sprague are an example of the shift.

Figure 15: Number of Permitted Units

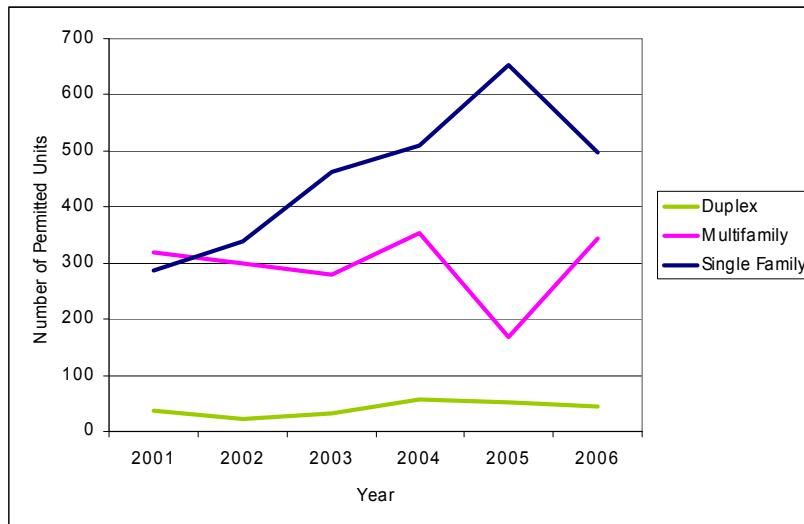

Source: City of Spokane, 2006

Figure 16: Recent Downtown Condominium, Loft and Townhouse Projects

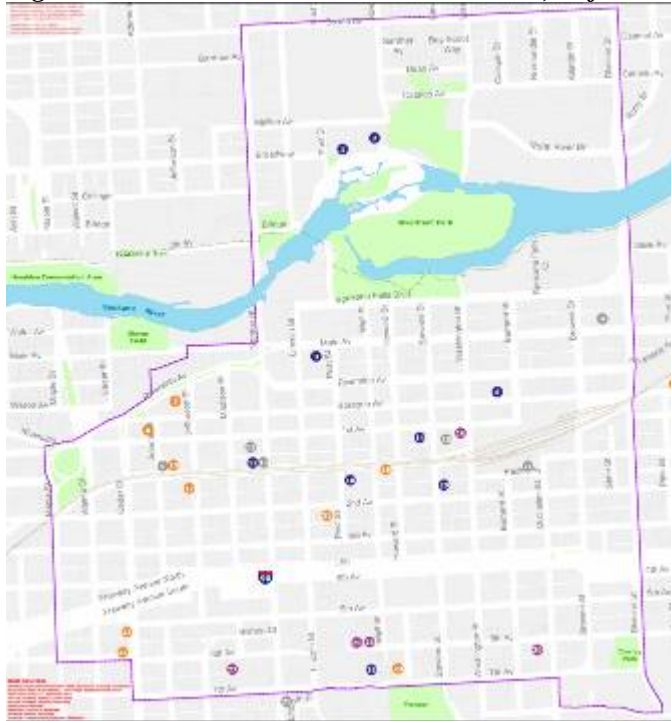

Source: City of Spokane, 2006.

Historical downtown office metrics show a consistently strong market even though the market is currently in a downturn (Figure 17 and Table 1). Historic rents show a fairly constant and gradual increase and vacancy rates for Class A office space were historically below 10 percent (Figure 18). Qualitative research has shown the main issue for the University District is lack of the right kind of office space. The companies that want to locate in the University District often need access to lab space. Since none of this kind of space is being built in downtown Spokane or the University District, these businesses are forced to locate in nearby business parks.

Figure 17: Historical Downtown Office Vacancy Rates

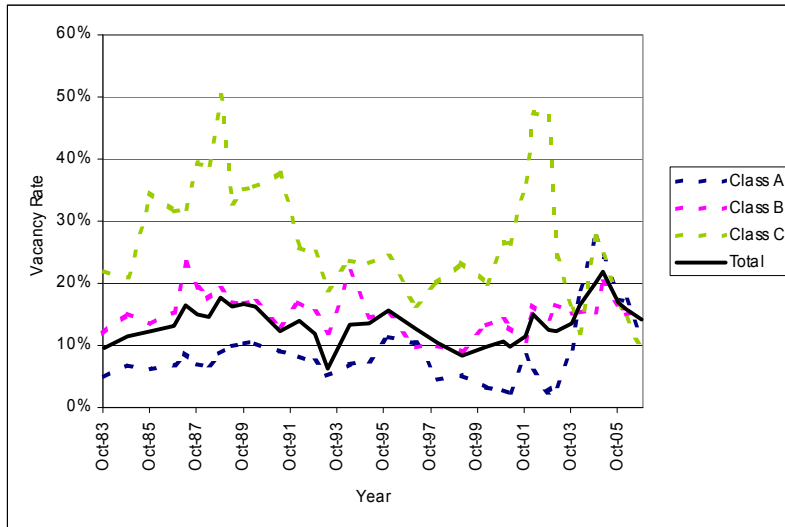

Source: *The Real Estate Report, Real Estate Research Committee, Dec 2006*

Figure 18: Historical Downtown Office Rents

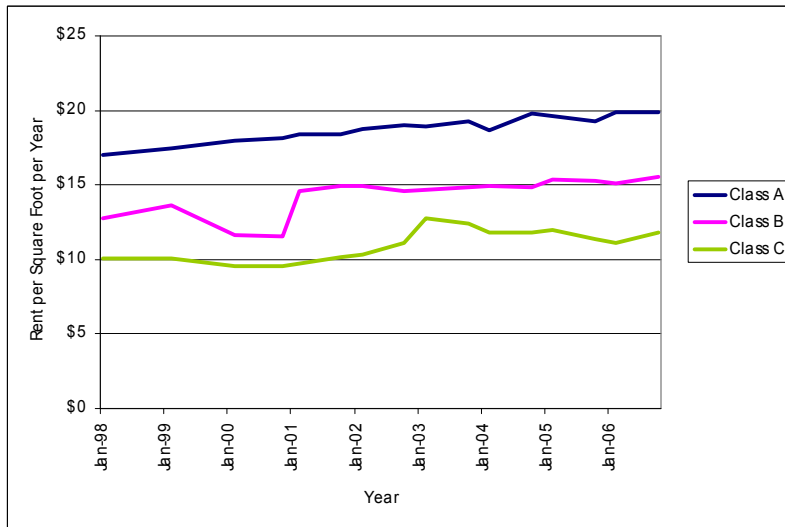

Source: *The Real Estate Report, Real Estate Research Committee, Dec 2006*

Table 1: Current Rental and Vacancy Rates

	Class A	Class B	Class C
Average Rental Rate	\$19.88	\$15.58	\$11.83
Vacancy Rate	11.52%	16.06%	9.44%

Source: *The Real Estate Report, Real Estate Research Committee, Dec 2006*

Projected Demand

Employment

Employment growth in Spokane is projected to continue to increase between now and 2030. By 2030, 77,473 new jobs are projected in the Spokane economy. This amounts to a 22.9 percent overall projected growth. Within the economy, the service sector is projected to comprise 37 percent of all jobs, for a total of 124,745 jobs. Job growth will support between two and three million additional square feet of office space every five years (Figure 19).

Figure 19: Projected Service Sector Demand for New Office Space

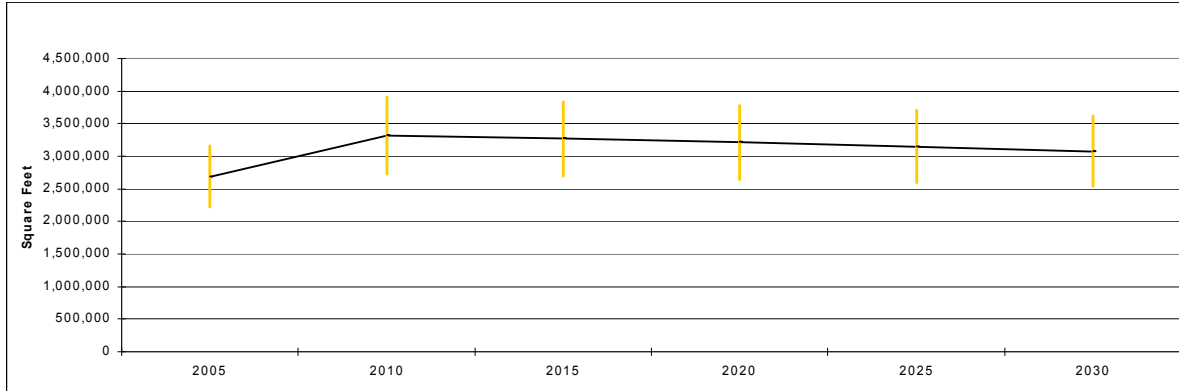

Source: Strategic Economics, 2006; Woods and Poole, 2005.

Housing

Over the next 20 years, it is expected that the population of Spokane County will increase faster than the population of Spokane. The Washington State Office of Financial Management developed population projections. Strategic Economics developed several three projections based on the OFM county projections. Using different assumptions about growth rate and the proportional share of county population, high, medium and low growth scenarios were developed. The City of Spokane is expected to have between 230,000 and 280,000 thousand people by 2025 (Figure 20). This represents an increase of approximately 20,000 and 60,000 people from 2006.

Figure 20: Historical Population and 2025 Projections

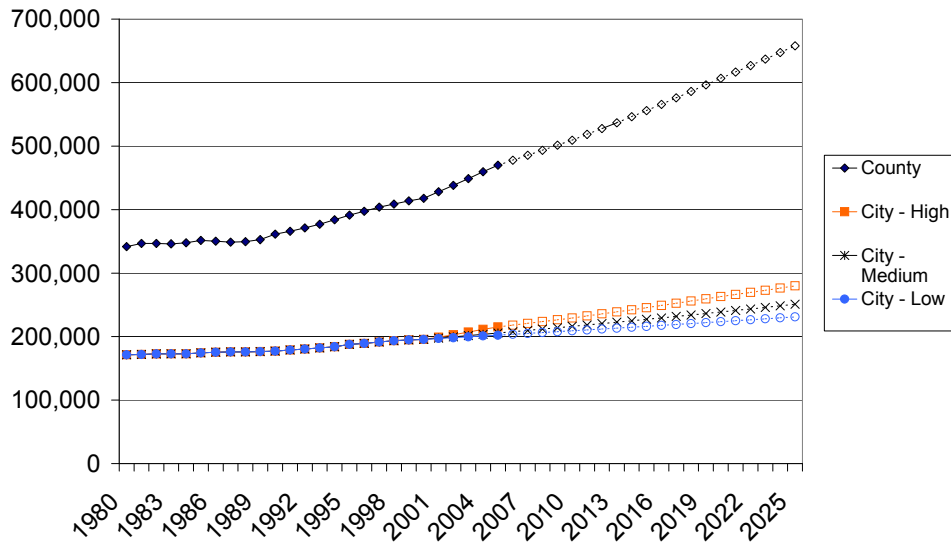

Source: Strategic Economics; 2000 US Census; Claritas, 2006; Office of Financial Management, 2006.

Using the city population projections, Strategic Economics estimated for each scenario how many additional households would be likely to locate in downtown Spokane. Strategic Economics estimated that approximately 50 to 75 percent of all target households² would choose to locate in dense housing types in downtown Spokane if the product was available. Strategic Economics estimated that there is demand for between 200 and 450 units per year in the downtown (Figure 21). This figure is in line with estimates developed by Zimmerman/Volk Associates in a 2003 market study. This study estimated a demand for approximately 300 units per year in downtown Spokane.

Figure 21: Projected Downtown Housing Demand

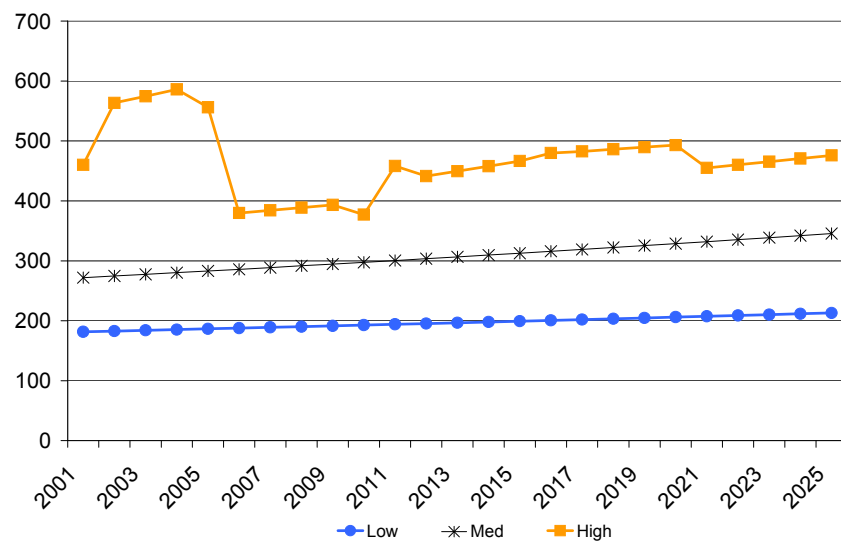

Source: Strategic Economics; 2000 US Census; Claritas, 2006; Office of Financial Management, 2006.

² Target households include singles, non-family households and family households above age 65. These households have shown a preference for locating in dense, urban areas.

One factor mitigating the demand for housing in downtown Spokane is the affordability of the units being constructed. Figure 22 shows affordable home prices by income. The lower range of the market for units in the downtown is approximately \$150,000. In order to be able to afford a home of that price, a household or person would need to make approximately \$50,000. Table 2 shows that approximately 30 percent of the population of Spokane can afford a home at this price. Target households make up approximately 25 percent of all households. However, at the mid-range of the market, between \$300,000 and \$500,000 only 10 percent of the population can afford these units. In order for Spokane to realize between 200 and 450 units per year, they must be in a price range affordable to Spokane target households.

Figure 22. Affordable Home Price by Income

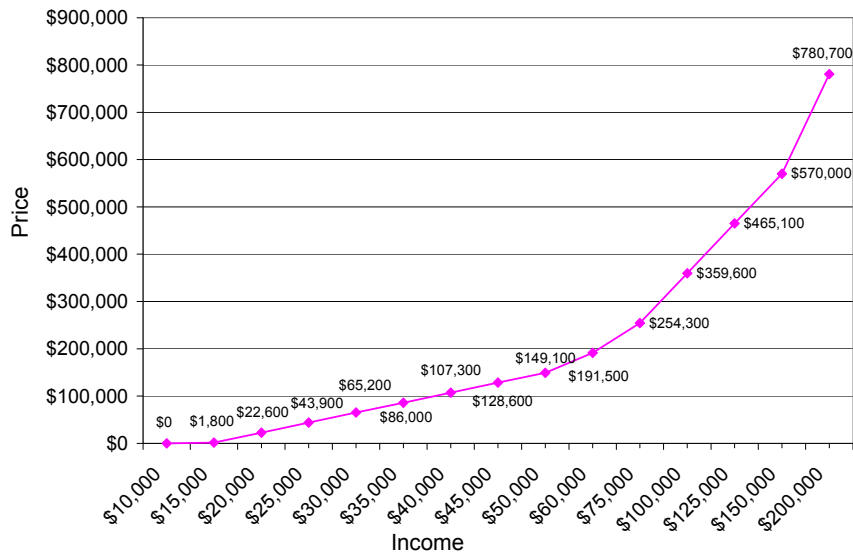

Source: Strategic Economics; 2000 US Census; Claritas, 2006; Office of Financial Management, 2006.

Table 2. Affordable Home and Rent Prices by Income

Income Distribution	Target Home Price		Target Rent		% Able to Afford Target Price
	Low	High	Low	High	
Less than \$10,000	\$0	\$0	\$0	\$150	100.00%
\$10,000 to \$14,999	\$0	\$1,800	\$150	\$275	87.29%
\$15,000 to \$19,999	\$1,800	\$22,600	\$275	\$400	78.64%
\$20,000 to \$24,999	\$22,600	\$43,900	\$400	\$525	70.24%
\$25,000 to \$29,999	\$43,900	\$65,200	\$525	\$650	62.30%
\$30,000 to \$34,999	\$65,200	\$86,000	\$650	\$775	54.24%
\$35,000 to \$39,999	\$86,000	\$107,300	\$775	\$900	46.41%
\$40,000 to \$44,999	\$107,300	\$128,600	\$900	\$1,025	39.86%
\$45,000 to \$49,999	\$128,700	\$149,100	\$1,025	\$1,150	34.29%
\$50,000 to \$59,999	\$149,100	\$191,500	\$1,150	\$1,400	29.79%
\$60,000 to \$74,999	\$191,500	\$254,300	\$1,400	\$1,775	21.33%
\$75,000 to \$99,999	\$254,300	\$359,600	\$1,775	\$2,400	13.08%
\$100,000 to \$124,999	\$359,500	\$465,100	\$2,400	\$3,025	6.46%
\$125,000 to \$149,999	\$465,100	\$570,000	\$3,025	\$3,650	3.50%
\$150,000 to \$199,999	\$570,000	\$780,700	\$3,650	\$4,900	2.12%
\$200,000 or more	\$780,700	+	\$4,900	+	1.19%

Source: US Census, 2000; Strategic Economics.

KEY MARKET FINDINGS

Market demand is strong, but the development community is uncertain.

The University District has great potential for both housing development and job growth, but the Developers and property owners don't have a clear vision for what the City wants in that area or of what investments are going to be made.

The most desirable development location in the area is between Spokane Falls and the railroad tracks. Major land assembly has been done in this area by WSU. For this land to be available to the private sector, it will require the participation of the university, willing developers and investors, and potentially some changes in state law concerning use of state-owned assets. Given projected enrollment in WSU and EWU over the next 50 years, the land between Spokane Falls Boulevard and the railroad tracks may not be fully used at buildout. However, it is likely that WSU may want to reserve some of the land for changes in enrollment. Remaining land could potentially be used for private sector redevelopment (housing, research and professional partnerships, clinical services, recreation/wellness, dining, retail), that benefit the city and the universities on the Riverpoint campus. One possible disposition strategy for WSU is to lease the land to commercial developers who would build office space that could be reclaimed for university use at a later date if needed.

Development should capitalize on existing synergies.

The synergism created by Sirti, WSU, EWU and area hospitals is helping to create successful businesses who want to be located in the University District. There is also a good match between the types of workers employed in the health/biomedical industries and those who have a demand for housing downtown. The health and biomedical industries draw primarily on a young, educated workforce. This same demographic has a preference for downtown living. These businesses find it easier to recruit workers who want to live close to their jobs. These businesses also have an easier time recruiting interns from nearby Universities.

The proposed infrastructure investments don't fully leverage development.

The street network proposed for the Riverpoint Campus as well as the Riverside extension doesn't fully maximize the potential to draw market momentum from downtown into the University District. The lack of a grid sub-optimizes the amount of development that can be accommodated in this area by creating incremental development parcels where the individual buildings are emphasized more than the overall street. Good urban design is the key to maximizing value in this area. Strategic Economics' research has found that good placemaking can add between 10 and 20 percent to the value of development.

As currently planned, the Riverside extension would widen the gap already created by the railroad tracks and possible future light rail right of way. If the area south of the railroad tracks is to capitalize off future growth in the University District and be integrated into the University District then this barrier needs to be made as small and permeable as possible. The best way to minimize the impact on development of barriers like railroad tracks is to envelop them in the urban fabric. In downtown Spokane, high-quality projects have recently been built that are adjacent to the railroad tracks.

Figure 23: University District Master Plan



Source: City of Spokane

Next Steps in Planning for the University District

If the City wants to maximize development in the University District their next step should be to create a plan for the University District that clearly delineates blocks and streets, defined major land uses, and specifies what public investments will be made for streets, streetscape and other public amenities. The plan would accomplish the following:

Provide certainty for the market and establish a street network that allows for incremental development.

The best way to spur growth and economic development in the University District is to provide certainty for the market. Establish a detailed plan for the University District so developers, business owners and residents have a clear idea of what investments the City will be making in the future and what kinds of development are appropriate for this area.

Incremental development should be made possible by continuing the street grid both between Spokane Falls Boulevard and the railroad tracks and between the railroad tracks and Sprague Ave. Continuing the pattern will allow for orderly incremental development. Planning out the street grid will also help to reduce the number of undevelopable or oddly shaped parcels created in this area. Minimizing the barrier of the railroad tracks is also a key step to development south of the railroad tracks.

Ensure ongoing synergy between jobs and housing.

Preventing the dissipation of jobs and housing out of the University District meets the economic development goals of the City. By encouraging and investing in plans and implementation strategies that result in residential and office development in the University District, the City can enhance the existing synergy.

Prioritize City resources

The City can leverage more return and development from their investments by focusing their efforts in the University District. Market momentum is currently focused on downtown, but will shift to the University District next. The combination of both public and private investment in the University District will result in better and possibly more development than if each invested on their own.

Move catalyst projects forward.

The development community is often hesitant to try out new markets if the perceived risk is great. Lenders are also hesitant to loan money to projects building untested products or in transitional areas. Catalyst projects show the development community as well as lenders that development is feasible and opens the door for more projects. If the City wanted to help spur development in the area, they could work with the University to reuse the Jensen Byrd Building for office space and other compatible uses.

APPENDIX C: KEY ISSUES BRIEFING PAPER

Continued U District Growth and Development: Paths Forward

A central topic of discussion at the Smart Growth workshop January 17 – 19 was whether the Riverside Avenue investment, *as planned*, would be the best way to support Spokane's goals for the University District, and if not, what alternatives might be more supportive of Spokane's goals. This memo evaluates the alternatives against Spokane's objectives for the area.

Spokane's Smart Growth Objectives

Most of these objectives are taken from local planning documents – including the *University District Master Plan*, *Riverpoint Campus Master Plan* and the *Spokane Comprehensive Plan*. Others were identified by participants in the smart growth workshop.

1. Integrate the Riverpoint Campus with the rest of the University District and Downtown Spokane such that the public's investment in the campus leverages nearby infill residential development and new office/R&D projects thereby reinforcing the ongoing urban resurgence in Spokane.
2. Plan, design and build out the Riverpoint Campus as a modern urban college campus that is seamlessly integrated into the surrounding urban core to support, and provide places for, spin-off development related to university research programs, SIRTI, and the medical complex to the south.
3. Build a well-connected grid of small streets in and around the Riverpoint Campus rather than a few poorly connected wide, high-speed streets, and thus:
 - a. improve circulation and access within the campus;
 - b. avoid barrier streets with associated impacts to walking environments; and,
 - c. provide an urban street network that supports urban infill development.
4. Limit growth in pass-through traffic on the Riverpoint Campus to reduce negative impacts of traffic and facilitate development of a pedestrian-oriented campus.
5. Expedite drawdown of transportation funding (federal, state and local) allocated to the extension of Riverside Avenue to ensure that this major public infrastructure investment is expended to catalyze private sector investment and improve access and circulation on the Riverpoint Campus.
6. Support conversion of one-way streets in the downtown core to two-way circulation (Main and Spokane Falls Blvd.) as a means of improving local connectivity between the University and East End District and improving the pedestrian environment within the University District.
7. Use transit investments to increase transportation choices in the University District and to support a pedestrian-orientation on the Riverpoint Campus, manage air quality, and provide a transit-oriented development (TOD) environment to further support private and public investment in the U District.
8. Provide a highly visible pedestrian/bicycle connection across the railroad corridor from the Sprague area to the Riverpoint Campus and thus:
 - a. connect the Riverpoint Campus to the south part of the University District and the residential neighborhoods and hospital complex south of I-90;
 - b. provide an iconic landmark giving identity and "address" to areas on both sides of the tracks;
 - c. anchor a future transit center with cross-platform transfers between bus and rail transit; and,
 - d. support and catalyze redevelopment along East Sprague Avenue.
9. Preserve historic buildings and provide access to them that encourages their rehabilitation and reuse.
10. Reduce the impact of the railroad corridor as a dividing barrier between the Riverpoint Campus and the rest of the City and diminish its impact on the investment potential of nearby lands by integrating it into a dense urban development pattern.

Transportation Corridor Options

Current plans developed by the City in conjunction with the two Universities, the State Legislature and other entities call for the extension of Riverside Avenue through the Riverpoint Campus immediately adjacent to the Burlington Northern/Santa Fe rail corridor and (in future phases) on to the east to connect to Trent Avenue east of North Hamilton Street. This project is intended to reduce pass-through traffic on Spokane Falls Boulevard through the heart of the Riverpoint Campus. The first phase of the project is partially funded. Because of impacts to historic buildings, a draft Environmental Assessment has been prepared as a means of addressing Section 4(f) requirements.

During the smart growth workshop several alternatives to this project were identified. These are described and compared below.

Riverside Extension (Current Plan): The Riverside extension project is intended to allow consolidation of the Riverpoint campus by downgrading Spokane Falls Blvd. between Division Street and Hamilton, and within the campus. Some of the future pass-through traffic would be shifted out of the core campus by extending Riverside Avenue (two general purpose lanes with left turns as needed) from Division Street to Perry Street, with an alignment continuing to the east along the south bank of the Spokane River. Due to its size, the project has been broken into three phases; Phase 1 would provide a half-mile extension of Riverside east from Division Street, curving to the north near the eastern border of the WSU Spokane campus (west side of the Spokane River), then connecting to Spokane Falls Blvd prior to the new Trent Avenue Bridge. Phase 2 would extend Riverside Drive 3/4-mile further east along the south side of the Spokane River to connect with Trent Avenue at Perry Street. Phase 3 would connect the eastern portion of the Riverside extension with an extended Erie Street tying into the East Sprague Business District.

Main Street Extension: This alternative would implement the same general traffic distribution strategy as the Riverside Extension: Spokane Falls Boulevard would be downsized through the Riverpoint Campus and a new corridor would be developed connecting across the south part of the campus to Trent Avenue east of Hamilton. This alternative differs in that the new corridor would be located one block farther north, connecting directly across Division to West Main Avenue. This corridor would proceed east across the campus tying into the same alignment proposed for the Riverside Extension in Phases 2 and 3. Hence, only Phase 1 of the project would be different than the current plan. This new street would be designed as an urban “downtown-like” street with on-street parking and continuous sidewalks. It would connect with a network of north-south streets thereby encasing future building sites within an urban street grid similar to, and echoing the existing grid found throughout the core districts of urban Spokane. This new street would include two general purpose lanes with left turn provision as appropriate. With this alignment, it would be possible to line the street with infill development on two sides.

Hybrid Approach: This alternative would combine the current proposed Riverside Avenue Extension project as described above with a more complete network of local streets on the Riverpoint Campus south of Spokane Falls Blvd., including extending Main Street into the campus. This is intended to capture as many of the concepts developed in the smart growth workshop as possible, except for the realignment of the proposed Riverside Avenue investment.

The options comparison table on the next page draws on the ten smart growth objectives identified on page 1 to provide a basis for comparison. Each option is evaluated as either providing **STRONG**, **MODERATE** or **WEAK** support to achievement of each of the ten objectives. In one case two of the options would **FAIL** to meet an objective entirely.

These are subjective, qualitative assessments that are intended as a starting point for discussion and decision. Nonetheless, the comparison table suggests that the Main Street Extension option substantially better fulfills the goals that Spokane has set for itself.

Key Issues and Opportunities - University District Implementation

Comparison of Transportation Corridor Options

	Riverside Extension	Main Street Extension	Hybrid Approach	Notes
1. Integrate the Riverpoint Campus	WEAK	STRONG	WEAK	The Main St. option would connect the campus to the South and to the West.
2. Modern Urban College Campus	WEAK	STRONG	MODERATE	The Riverside Extension option reinforces a suburban campus layout and would not provide internal street addresses for new buildings in the south campus.
3. Well-Connected Grid of Small Streets	WEAK	STRONG	MODERATE	The Main Street option facilitates development of a complete grid; the Hybrid option provides a partial grid.
4. Limit Growth in Pass-Through Traffic	STRONG	STRONG	STRONG	All alternatives would allow the City to limit growth in pass-through campus traffic.
5. Expedite Drawdown of Transportation Funding	STRONG	MODERATE	STRONG	The Main Street option requires design revisions which could affect the construction schedule.
6. Conversion of One-Way Streets to Two-Way Circulation	WEAK	STRONG	WEAK	The Main Street option not only supports, but requires the conversion of W. Main and Spokane Falls Blvd. to two-way operation.
7. Transit-Oriented Development	WEAK	STRONG	MODERATE	The Main Street option allows integration of a transit center into a local street/pedestrian network and does a better job of capitalizing on the ped/bike bridge connection.
8. Highly Visible Ped/Bike Connection Across RR Corridor	WEAK	STRONG	WEAK	Extending Riverside along the railroad would require a longer, more expensive bridge and would adversely affect its design and function.
9. Preserve Historic Buildings	FAIL	STRONG	FAIL	The Main Street option would allow preservation of a Riverside Ave. historic warehouse building that would be lost with the Riverside Extension. The Main Street option would also facilitate reuse of the Jensen-Byrd building.
10. Reduce Impact of the RR Corridor	WEAK	STRONG	MODERATE	The Riverside Extension and Hybrid options create a wide transportation corridor along the south edge of campus that would be a major negative space in the local urban development pattern.
# of Strong	2	9	2	

Riverside Extension (Current Plan)



Main Street Extension (Option)



Hybrid Approach (Option)

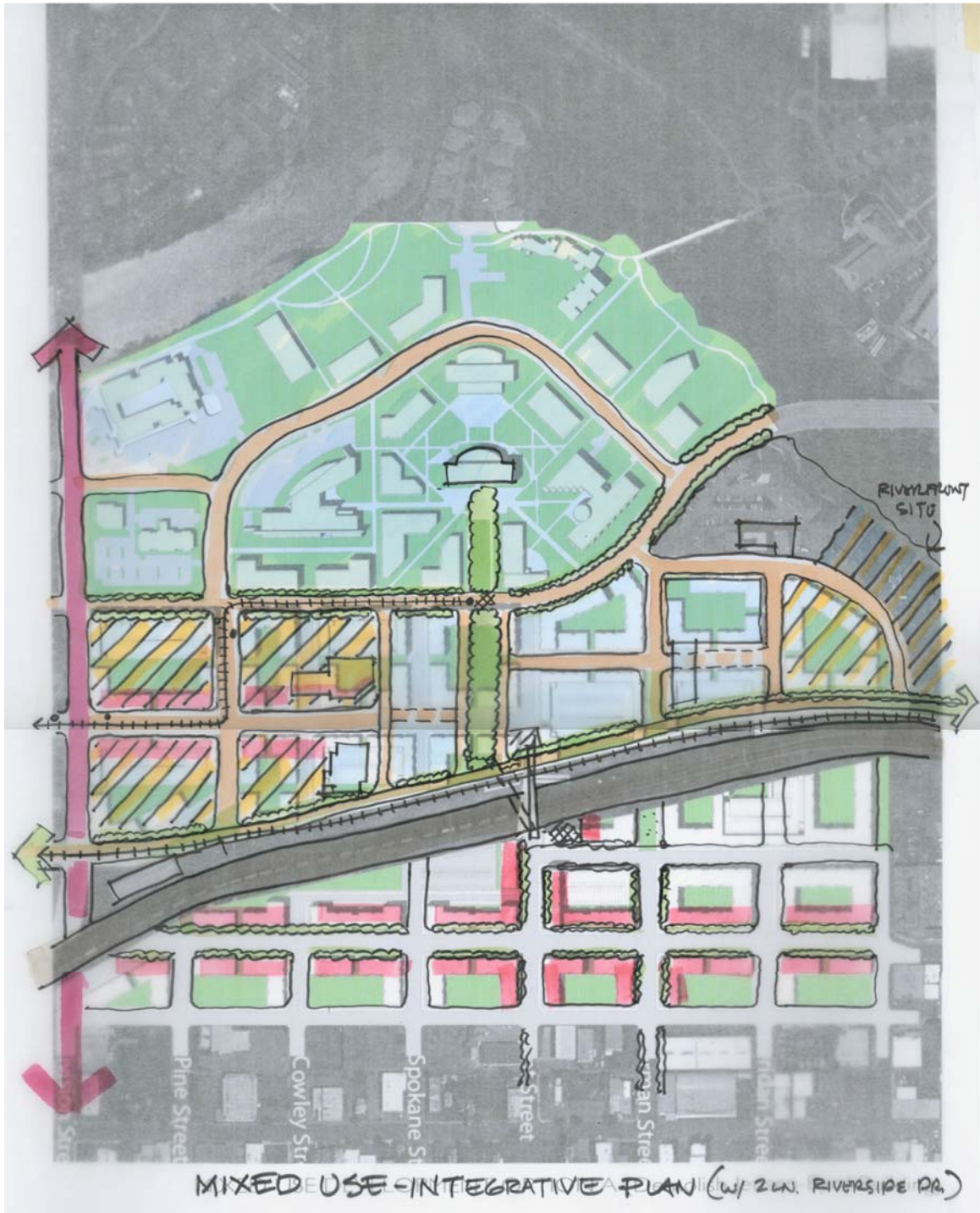

APPENDIX D: RIVERPOINT CAMPUS DEVELOPMENT PROGRAM



*All proposed buildings are 4 stories

- Mixed Use
- Existing Retail
- Multi-Family Residential
- Campus
- Existing Campus
- Public Green Space
- Existing Building
- New Building

Scale: 1" = 200'

Riverside Alignment - Draft Plan Spokane, Washington



**VAN METER
WILLIAMS
POLLACK**
ARCHITECTS + PLANNERS

3.13.07

Block Spreadsheet

Block #	Acres	Existing Building Footprint	Recommended existing campus building parking 2 per 1000 SF	Existing Retail	New Retail in Existing Building	New Retail (1 Level)	Recommended retail parking 3 per 1000 SF	New Multi-Family Units in existing building	New Multi-Family Units (4 levels)	Recommended residential parking 1 per Unit	New Live Work in existing building	Recommended live work parking 2 per Unit	New Campus Buildings 4 Levels	Recommended campus parking 2 per 1000 SF	Total recommended parking for all programs	Total Parking Provided including Structured, Street, & Angled	Structured Parking	Street Parking	Angled Parking
Block 1	3.1	16,500 SF		14,850 SF		19,283 SF	102		150	150					252	390	120x240 (3.5 levels) 90 spaces/level 315 spaces	42	33
Block 2	9.7	68,850 SF	86	7,020 SF		14,355 SF	432	155	290	445			90,000 SF	180	857	736	(2)120x240 (3.5 levels) 90 spaces/level 630 total spaces	106	
Block 3	4.9												415,200 SF	830	830	71		71	
Block 4	6.4	68,800 SF	137										240,850 SF	481	647	1264	L-Shaped (3.5 levels) 157 spaces/level 552 spaces 180x320 (3.5 levels) 180 spaces/level 630 spaces 1182 total spaces	82	
Block 5	2.8	4,000 SF		3,600 SF		28,080 SF	95		125	125					265	390	120x240 (3.5 levels) 90 spaces/level 315 spaces	42	33
Totals	26.9	158,150 SF	223	25,470 SF		61,714 SF	629	155	565	720			746,050 SF	1,491	2,851	2,851			

Total New Retail = 61,714 SF Total New Dwelling Units = 720 Total Campus Addition = 746,050 SF Total Parking Provided = 2,851

Riverside Alignment Block Descriptions

Block 1: (3.1 acres)

- Contains existing retail, new retail, new residential, and a parking structure.
- Site self parks and also parks a portion of the retail in Block 2

Block 2: (9.7 acres)

- Contains existing retail, new retail, new residential, new campus buildings, two vacant buildings, one 2 stories, the other 6 stories, an existing 2 story lab, and two parking structures.
- The existing vacant buildings in the center of the site will be converted into residential
- The two parking structures park the residential units and the remainder is designated for campus parking. Blocks 1 & 5 park retail.

Block 3: (4.9 acres)

- Contains new campus buildings and an open space.
- The pedestrian bridge connects to this block.

Block 4: (6.4 acres)

- Contains an existing campus building, new campus buildings, and two parking structures.
- The two parking structures not only park the block but also provide most of the campus parking for Block 3.

Block 5: (2.8 acres)

- Contains existing retail, new retail, and new residential, and a parking structure.
- The parking structure self-parks the site and provides parking for the retail located on Block 2

- All new buildings including mixed use, residential, and campus are 4 stories.
- All proposed parking structures are 3.5 levels or 2.5 decks.
- All parking is based on shared parking schemes

Riverside Alignment - Draft Program
Spokane, Washington

Revised
4.26.07

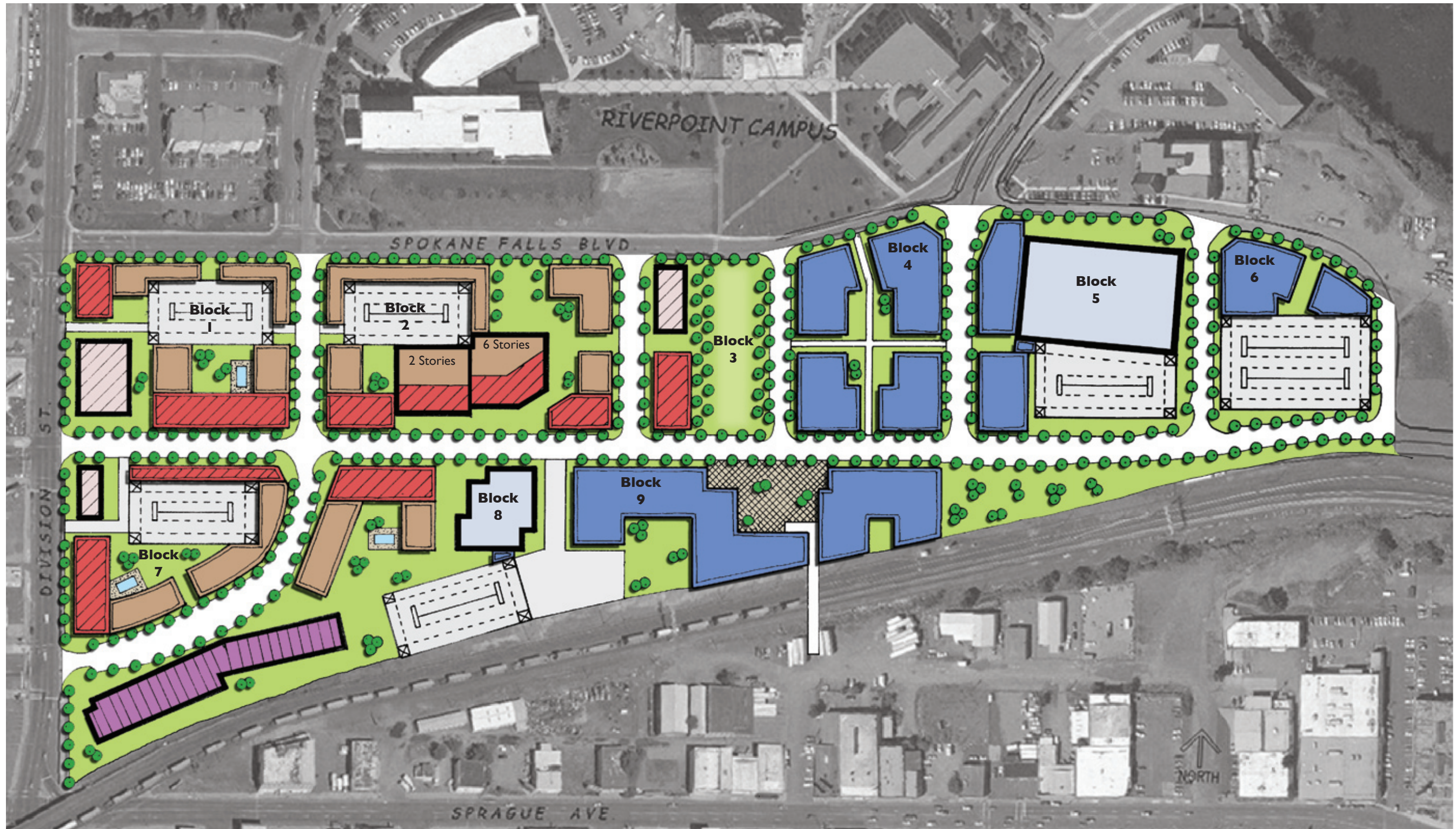

* All proposed buildings are 4 stories

- Mixed Use
- Existing Retail
- Live Work
- Multi-Family Residential
- Campus
- Existing Campus
- Public Green Space
- Existing Building
- New Building

Scale: 1" = 200'

Main Street Alignment - Draft Plan Spokane, Washington



**VAN METER
WILLIAMS
POLLACK**
ARCHITECTURE • LANDSCAPE

3.13.07

Block Spreadsheet

Block #	Acres	Existing Building Footprint	Recommended existing campus building parking 2 per 1000 SF	Existing Retail	New Retail in Existing Building	New Retail (1 Levels)	Recommended retail parking 3 per 1000 SF	New Multi-Family Units in existing building	New Multi-Family Units (4 Levels)	Recommended residential parking 1 per Unit	New Live Work in existing building	Recommended live work parking 2 per Unit	New Campus Buildings 4 Levels	Recommended campus parking 2 per 1000 SF	Total recommended parking for all programs	Total Parking Provided including Structured, Street, & Angled	Structured Parking	Street Parking	Angled Parking
Block 1	3.1	16,500 SF		14,850 SF		21,645 SF	109		183	183					292	390	120x240 (3.5 levels) 90 spaces/level 315 spaces	40	35
Block 2	4	39,400 SF			16,321 SF	14,445 SF	92	137	207	344					436	408	120x240 (3.5 levels) 90 spaces/level 315 spaces	48	45
Block 3	1.5	7,800 SF		7,020 SF		8,775 SF	47		27	27					74	54		35	19
Block 4	2.3												226,160 SF	452	452	63		39	24
Block 5	3.8	68,800 SF	137										110,400 SF	220	357	427	120x270 (3.5 levels) 101 spaces/level 353 spaces	45	29
Block 6	2.1												138,080 SF	276	276	791	180x290 (4.5 levels) 163 spaces/levels 733 spaces	34	24
Block 7	2.9	4,000 SF		3,600 SF		21,150 SF	74		143	143					217	375	120x240 (3.5 levels) 90 spaces/level 315 spaces	35	35
Block 8	4.8	39,510 SF	86			11,115 SF	33		117	117	26	52 - parked in building			288	427	120x240 (3.5 levels) 90 spaces/level 315 spaces	28	32
Block 9	4.5												305,700 SF	611	611	104		0	104
Totals	29	176,010 SF	223	25,470 SF	16,321 SF	77,130 SF	355	137	677	814	26	52	780,340 SF	1,559	3,003	3,039		304	347
Total New Retail = 93,451 SF Total Dwelling Units = 840 Total Campus Addition: 780,340 SF Total Parking 3,039																			

Main Street Alignment Block Descriptions

Block 1: (3.1 acres)

- Contains existing retail, new retail, new residential, and a parking structure.
- Site self-parks both retail and residential and provides retail parking for Block 2

Block 2: (4.0 acres)

- Contains new retail, new residential, two vacant buildings, one 2 stories, the other 6 stories, and a parking structure.
- The existing vacant buildings will have retail and residential on the ground floor and residential on upper floors.
- The site parks the residential portion for both Block 2 and 3, while Block 1 accommodates the retail parking.

Block 3: (1.5 acres)

- Contains existing retail, new retail, new residential, and an open space.
- The pedestrian bridge connects to this block.
- Street parking and Block 2 accommodate the block's parking requirements.

Block 4: (2.3 acres)

- Contains new campus buildings.
- Street parking and Blocks 5 & 6 park this site.

Block 5: (3.8 acres)

- Contains an existing campus building, new campus buildings, and a parking structure
- The parking structure self-parks the site and provides parking for the campus buildings on Blocks 4 & 9

Block 6: (2.1 acres)

- Contains new campus buildings and a parking structure
- The parking structure parks the site and provides parking for the campus buildings on Blocks 4 & 9

Block 7: (2.9 acres)

- Contains existing retail, new retail, new residential, and a parking structure.
- The site self-parks and also parks the retail component of Block 8

Block 8: (4.8 acres)

- Contains existing lab building, existing building to be converted to live-work units, new retail, new residential, and a parking structure.
- Block 7 parks the retail component; the structure parks the residential component except live-work which self-parks. The remainder of the parking is for the lab and campus building on Block 9.

Block 9: (4.5 acres)

- Contains new campus buildings and an open space
- Blocks 8, 5, & 6 provide the parking for this block.
- The pedestrian bridge connects to the block.

- All new buildings including mixed use, residential, and campus are 4 stories.
- All proposed parking structures are 3.5 levels or 2.5 decks.
- All parking is based on shared parking schemes

Main Street Alignment - Draft Program
Spokane, Washington

Revised
4.26.07

APPENDIX E: RETAIL ORIENTED STREET CASE STUDY ¹

¹ Excerpt from ITE Recommended Practice: Context Sensitive Solutions in Designing Major Urban Thoroughfares for Walkable Communities, <http://www.ite.org/css/>

Design Example #1: Creating a Retail-Oriented Main Street

Objective

Design a commercial-oriented street that supports an adjacent mix of retail, restaurants and entertainment uses on the ground floor.

Stage 1: Review or develop an area transportation plan

Review the area transportation plan to determine how the subject thoroughfare relates to the overall network, types of modes served, functional classification and existing and future operational characteristics, etc. Collect existing and projected data as necessary.

Existing Street Characteristics

Existing street is a four-lane, undivided collector street with the following characteristics:

- Functional classification: minor collector;
- Right-of-way: 60 ft.
- On-street parking: none
- ADT: 10,000–13,000 vpd
- Speed limit: 35 mph
- Percent heavy vehicles: 2–3 percent
- Intersection spacing: 600–700 ft.
- Network pattern: grid
- Center turn lane: none
- Transit: low frequency local route
- Bicycle facilities: not a designated bike route
- Sidewalks: 6-ft. wide on both sides
- No landscaping
- Conventional street and safety lighting

Stage 2: Understand community vision for context and thoroughfare

Vision

An existing commercial street in a suburban (C-3) area undergoing change to an urban center (C-5) emphasizes an active street life achieved through the mix and intensity of land uses, site and architectural design with an emphasis on pedestrian facilities and on-street parking.

Stage 3: Identify compatible thoroughfare types and context zones

Existing context is identified by assessing the character and attributes of existing land uses such as building orientation to the street, building height, parking orientation and mix and density of uses, etc. Future context is determined by interpreting the vision, goals and objectives for the area. Thoroughfare type is selected based on the urban thoroughfare characteristics (Table 3.4 in Chapter 3).

- Existing context zone: C-3
- Future context zone: C-5
- Thoroughfare type: avenue

Stage 4: Develop and test the initial thoroughfare design

Desirable Design Elements (in prioritized order based on vision)

- Lower operating speed
- On-street parking
- Wide sidewalks
- Street furniture and landscaping including benches and space for cafes, public space, etc.
- Pedestrian-scaled lighting
- Street trees
- Bus stops with shelters
- Transitions between main street and adjacent higher-volume segments
- Mid-block crosswalks
- Bike lanes

Factors to Consider/Potential Trade-Offs

- Right-of-way constrained to 60 ft.
- Maximizing parking with angled vs. parallel parking
- Reduction in the number of through lanes and vehicle capacity vs. wider sidewalks and on-street parking

- Accommodation of large vehicles vs. narrowing lane width and smaller curb return radii; and
- Accommodation of bicyclists vs. width of other design elements.

Alternative Solutions

1. Emphasize vehicular capacity by retaining existing four-lane section with 9-ft. wide travel lanes to allow 12-ft. wide sidewalks.
2. Emphasize parking by providing angled parking on one side, parallel parking on the other side and narrowing the two travel lanes.
3. Emphasize parking and wider sidewalks by providing parallel parking on both sides, two travel lanes and 12-ft. wide sidewalks.
4. Emphasize parking and vehicular capacity with parallel parking on both sides, 9-ft. wide sidewalks, two travel lanes and a center turn lane

Selected Alternative

Alternative #3:

- Maximizes sidewalk width
- Provides moderate to good level of on-street parking
- Balances street width with accommodation of larger vehicles and speed reduction
- Allows for left-turn lanes at intersections

Stage 5: Develop detailed thoroughfare design

Solution Design Features

Traveled Way:

- Target operating speed: 25 mph
- Two 10 ft. travel lanes
- Two 8 ft. parallel parking lanes

Roadside:

- 12 ft. sidewalks
- Pedestrian-scaled lighting
- Street trees in tree wells
- 6 ft. furnishings zone (includes 1.5 ft. edge zone)
- 6 ft. clear pedestrian throughway
- No frontage zone

Intersections:

- Curb extensions to reduce pedestrian crossing distance unless left-turn lane is provided
- High-visibility crosswalks
- Safety lighting
- Farside bus stops with curb extension and shelters
- ADA compliance



Figure 6.1A View of existing street. Source: Kimley-Horn and Associates Inc.

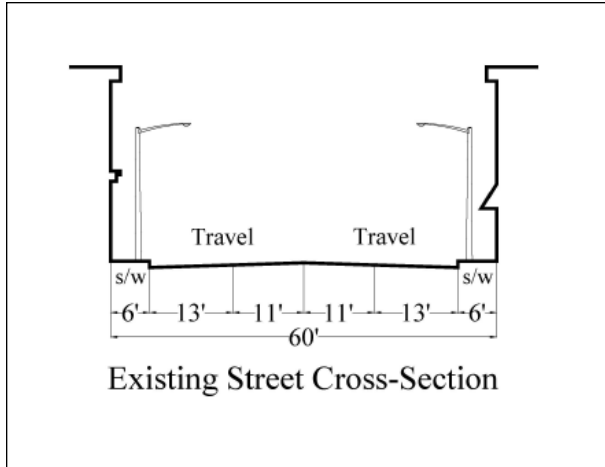

Figure 6.1B Existing street cross section. Source: Kimley-Horn and Associates Inc.

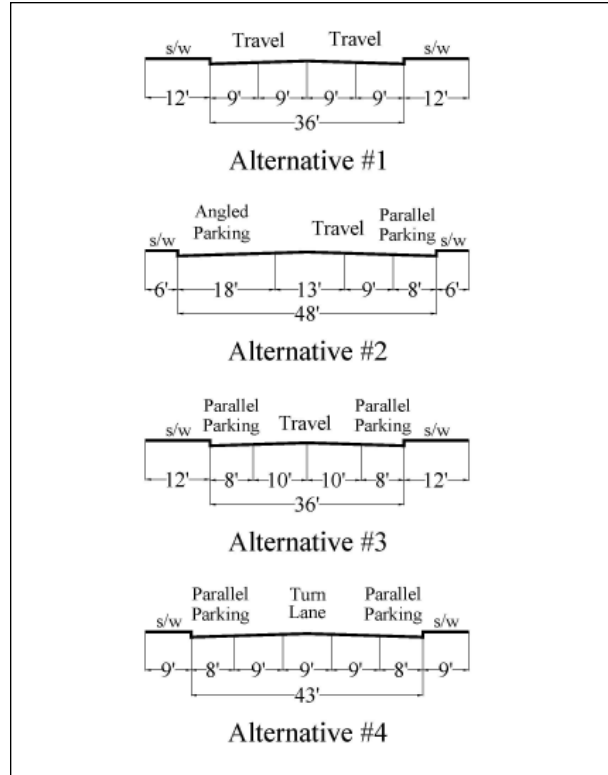

Figure 6.1C Alternative street cross sections. Source: Kimley-Horn and Associates Inc.

Relative Comparison of Trade-Offs									
Alternative	Parking	Sidewalk Width	Vehicular Capacity	Large Vehicle Accommodation	Pedestrian Crossing Width	Left Turn Lanes	Bike Accommodation	Ped. Amenity Accommodation	Speed Reduction
Existing	--	--	++	++	--	--	--	--	--
1	--	++	++	--	--	-	--	++	+
2	++	--	-	+	++	++	--	--	-
3	+	++	-	++	++	-	--	++	+
4	+	-	+	--	+	++	--	-	++

Score (relative to other alternatives)

- ++ Good (achieves objectives)
- + Fair
- Poor
- Fails to meet achieve objectives

Figure 6.1D Relative comparison of alternative trade-offs. Source: Kimley-Horn and Associates Inc.

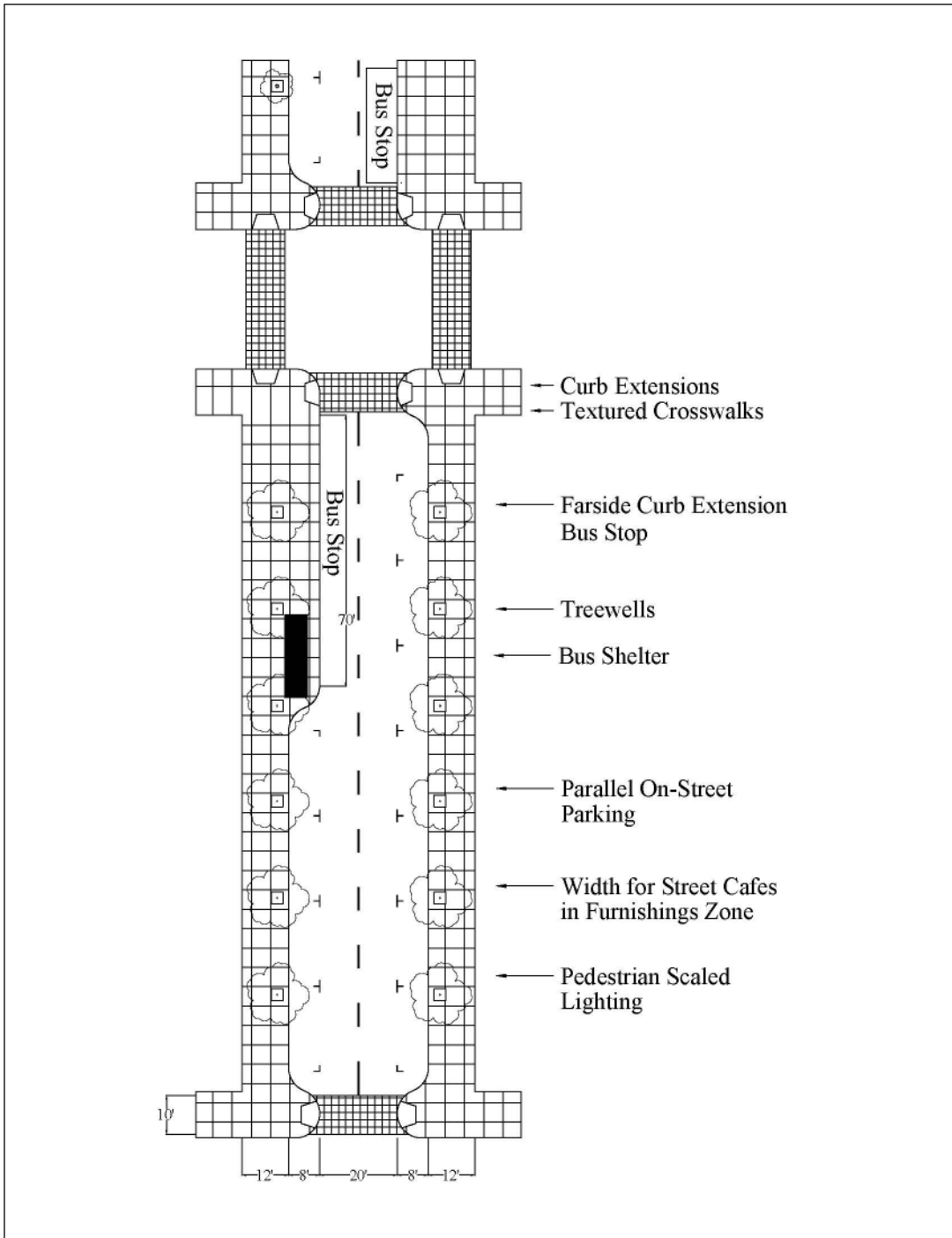

Figure 6.1E Schematic plan view of Alternative #3. Source: Kimley-Horn and Associates Inc.

APPENDIX F: BUFFALO NIAGARA MEDICAL CAMPUS (BNMC) CASE STUDY

The Buffalo Niagara Medical Campus (www.bnmc.org) is a non-profit community economic development corporation in downtown Buffalo, New York. Its mission is “to cultivate a world-class urban medical center by facilitating collaboration among the region’s major health care and research-related institutions located on the campus.” BNMC carries out its mission by implementing the strategic plan created in 2002. Titled the “BNMC Master Plan & Implementation Strategy,” this effort brought the idea of “implementation” to the same level as the plan-making, demonstrating to stakeholders the importance of getting in place the actions necessary that allow for the realization of the community and economic benefits outlined in the plan.

<u>Member Institutions:</u>	<u>Campus Facts:</u>
<ul style="list-style-type: none">▪ Buffalo Hearing & Speech Center▪ Buffalo Medical Group▪ Hauptman-Woodward Medical Research Institute▪ Kaleida Health▪ Olmsted Center for the Visually Impaired▪ Roswell Park Cancer Institute▪ University at Buffalo▪ Upstate New York Transplant Services	<ul style="list-style-type: none">▪ 100 acres in downtown Buffalo▪ Approximately \$600 million in annual expenditures▪ An additional \$300 million in annual economic impact▪ 8,000 employees▪ Over 750,000 annual patient visits

The guiding principles for the plan are:

- Establish a common campus address
- Improve physical integration between campus and neighborhoods
- Foster community and economic development
- Enhance the open space network.

BNMC is run by a board consisting of 20 members and a professional staff of 5. The annual budget is approximately \$600,000 per year. A trustees council of about 40 neighborhood organizations, local businesses, and partner institutions serves in an advisory role and helps BNMC carry out its mission. The district as a whole is approximately 100 acres, exclusive of two residential neighborhoods adjacent to the district that participate in BNMC activities and services. The organization is funded by its member organizations. Its programming comes from a variety of sources including direct governmental appropriations, grants, cooperative agreements, and charitable contributions. Each year, the area sees approximately \$600 million in expenditures and an additional \$300 million annual economic impact. There 8,000 jobs in the district, including 500 MDs and 200 PhDs.

Making connections and achieving community development outcomes

The ramping up of BNMC’s work, its governing structure, and the process that led to its current activities is a model that is likely replicable in other places. BNMC had existed since the early 1980s, but it’s been since 2001 that its most beneficial outcomes have been

accomplished. In the spring of 2001, the Mayor of Buffalo was Anthony M. Masiello. Mayor Masiello saw the need for a proactive organization that could plan for the growth of the area and help the downtown realize better economic and community development outcomes. To do this, Mayor Masiello directed staff and consultants to go on an information gathering and listening tour of all the stakeholders in the medical campus area. In addition, a new board chair was appointed. The new chair had the personal gravity, commitment to moving forward, and, importantly, the respect of the institutions in the district. These two decisions as well as the backing of the mayor were of paramount importance to BNMC effort.

The mayor's staff and consultants understood that the information gathering process had to be transparent and required the participation of the decision makers from the institutions that made up the medical campus and the other stakeholders in the district, including the neighborhoods. With the support of the chair of the board (previously he had been board chair of one of the institutions in the district), the mayor's staff and consultants met with the CEO of each institution and the chair of each institution's board. The logic of this was that the CEO had the best interest of the institution at heart, while the board chair was interested in both the institution and the community's well being. The discussion with these two leaders of each institution focused on the future – what could the institution be in the place that it was in? What were the institutions' needs, its capacity to satisfy those needs, and how that could happen? And, how could a community economic development corporation support the collective visions of the institutions and other stakeholders in the area? The process then shifted to the other stakeholders like the neighborhoods, the political leadership, and business and such in the district. Again, like with the institutions, it was important to the effort that the leadership – the decision makers – of these other groups were engaged on what they thought the future of the BNMC district could be.

With this step done, the mayor asked that the board be formed to reflect the needs and capacities of the member institutions and community members. Each of the five (at the time) major institutions were to have representation on the board, as was the mayor, city council president, and the adjacent neighborhoods. The board would carry out the BNMC mission by:

- **Coordinating** activities related to planning, development and enhancement within the 100-acre footprint
- **Facilitating** collaboration among our member institutions, as well as with the community at large
- **Addressing** issues of common concern to our institutions
- **Creating** a distinct environment that provides opportunities for active living.

In addition to the board, the mayor and the BNMC board chair recognized the need for staff to run the district. For the executive director position, they selected one of the consultants who had done much of the legwork engaging and listening to the institutions and stakeholders. With a sense that the governance – board and staff – were set, and the basic function of the organization was outlined – *coordinating, facilitating, addressing, creating* – the next issue was how to pay for this. The mayor, the BNMC board chair, and the new executive director went to a local foundation (Oshai) and secured a multi-year, multi-hundred thousand dollar commitment to support BNMC. With this commitment, the BNMC board chair and the executive director went to each institution and said, “the mayor wants this to

work, the Oshai Foundation has made a multi-year commitment, will you commit sustainable funding to make the BNMC work?” Across the BNMC board, the response was “yes.” The individual commitment varies according to the financial circumstances of each institution. The City of Buffalo has made contributions in a number of ways, including in-kind, funding for studies, planning, infrastructure investments, matching funds, and others. Oshai has continued to support BNMC’s work even after the commitment to year to year funding finished.

Master Planning and Implementation

One of the first things the new BNMC board did was to commission the architecture and urban design firm of Chan Krieger Sieniewicz to do a master plan and implementation strategy for the district. The process engaged over 2500 stakeholders in discussions of what the district could be. They created a vision for buildout of the district, showed how and where infrastructure investments could be made to support the vision, and outlined a process for growth that could support the multiple goals of the institutions, community members, and stakeholders. An overview of the plan is shown below. Of note is the urban character evident by the street network and building siting. BNMC has leveraged this plan (completed in 2003) to secure funding for development projects, transportation and pedestrian realm infrastructure, and urban design interventions that promote healthy living and daily physical activity.

Results as of April 2007

Infrastructure

Obtained \$14M in federal transportation dollars for streetscape and infrastructure improvements

- Ellicott Street priority project, will include a new street, curbs, sidewalks, furniture, & lighting – fall 2006 design, spring 2007 construction
- Streets throughout BNMC – 2008
- Allen Street extension project – 2009

Procured \$20M in state money to assist in recruiting nationally renowned scientists and doctors, and to increase accessibility to campus through infrastructure changes – implementation to begin 4th quarter 2006.

Campus Parking

BNMC is implementing a single, campus-wide parking program to enhance accessibility for all stakeholders. Parking provided for COE employees and tenants is coordinated through Campus Parking, which is an affiliate of BNMC.

Security

Developing a campus-wide public safety strategy; facilitating coordination among institutions, and between them and local law enforcement to provide enhanced communication among existing campus security personnel, installation of call boxes and security camera’s in public spaces, and expanding security patrol for the entire 100 acre campus.

Lessons

1. The first is that **leadership matters**. The Mayor of Buffalo wanted the BNMC district to be more than it was in 2001. He was instrumental in starting a process that led to a strategy for moving the district forward. It was well known early in the process that the mayor wanted to see better economic and community outcomes from the BNMC district. One of the early organizers of the district said that it was incredibly effective to be able to say to the institutional stakeholders that “the mayor wants this to happen.”
2. The second lesson is that the **planning process – the gathering of information and listening tour – has to be open, transparent, and genuine**. The mayor’s staff and consultants listened to the stakeholders’ concern about the district and used that information to come up with a realistic agenda for action and a governing structure that could be supported by the stakeholders as well as represent the varying interests appropriately.
3. Third, **governance of this type of organization must include vocal supporters and leaders that may have traditionally opposed the efforts**. One purpose of the open and transparent planning process is to hear out all stakeholders. BNMC found that it was better to be inclusive of stakeholders that may have expressed doubts about the agenda than to close them out of the organization. Over time, leaders in the neighborhood groups that were wary of the work in the district have come around and are not only supportive of the work (in part because they are included in the decision making), but are reaping the benefits of the services provided by BNMC and the better community outcomes that come from the economic growth.
4. Fourth, **BNMC is a complement to the city, not a competitor**. The organization is nimble, has access to funding sources not available to the city, and has the ability to leverage resources in the name of promoting progress in the district. BNMC provides planning and implementation services to the adjacent neighborhoods, for instance, which just helps the already overextended city.

Contacts

- Matt Enstice, BNMC Executive Director, menstice@bnmc.org, 871-881-8920
 - Michael Ball, BNMC Director of Planning and Implementation mball@bnmc.org, 871-881-8922
-

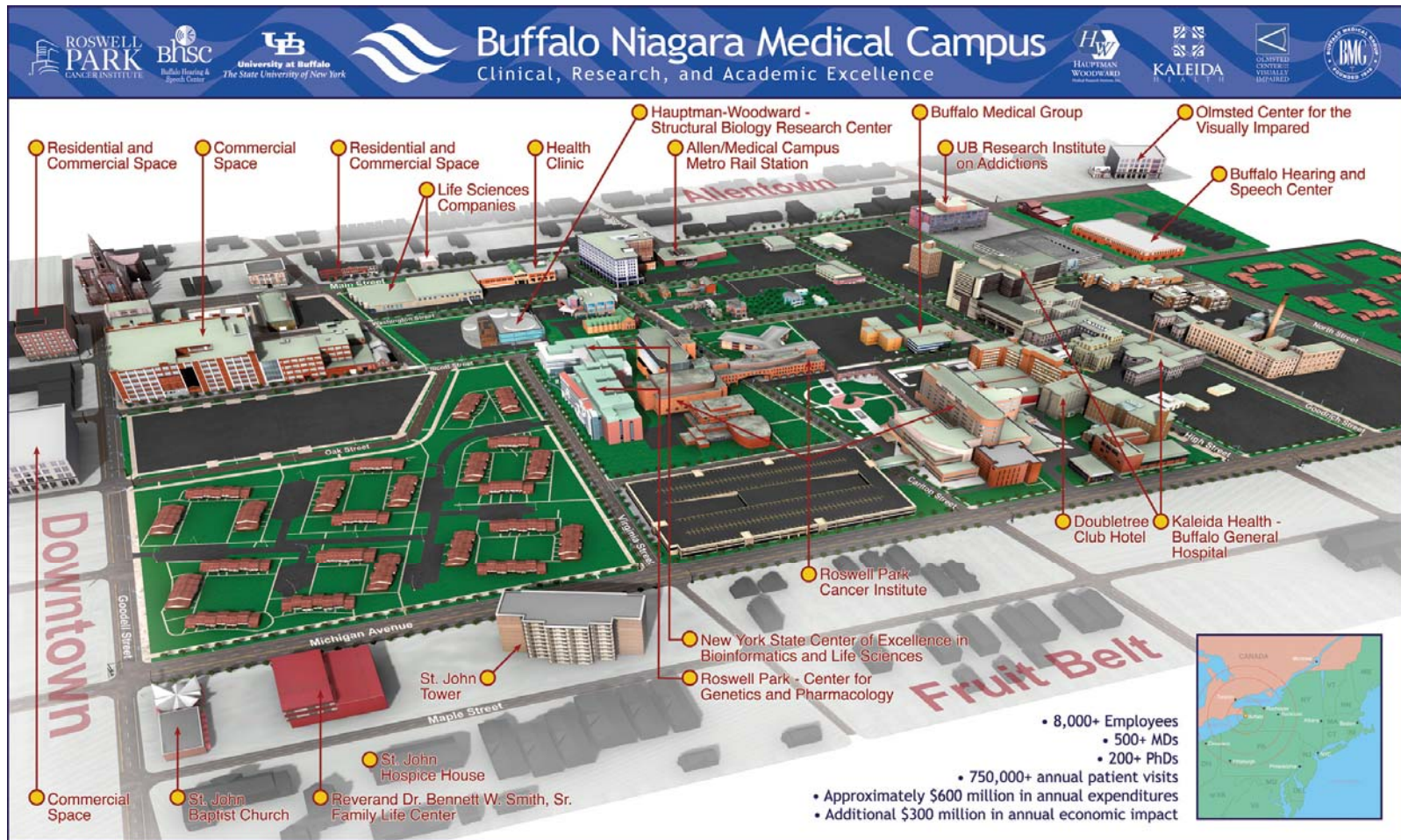

Figure 1: BNMC Campus map showing the location of the member organizations and the adjacent neighborhoods