

**FINAL REPORT**  
**PROTECTING INSTREAM FLOWS FOR FISHES IN THE NORTH BAY**



**California Land Stewardship Institute**

**550 Gateway Dr. #108**

**Napa, Ca. 94558**

**Grant Number: X7-00T04701-0**

## Table of Contents

<b>Summary: Protecting Instream Flows for Fishes in the North Bay</b>	<b>1</b>
<b>Task 2: Factors Influencing Implementation of Alternative Frost Control Measures</b>	<b>5</b>
<b>Task 3: Pilot Studies</b>	<b>89</b>
<b>Task 4 Quality Assurance Project Plan</b>	<b>106</b>
<b>Appendix A</b>	<b>119</b>

## SUMMARY: PROTECTING INSTREAM FLOWS FOR FISHES IN THE NORTH BAY

### TASKS ACCOMPLISHED

#### **Task 1. Perform Project Management**

The California Land Stewardship Institute (CLSI) prepared 19 invoices and 11 quarterly reports as part of the project management for this contract.

#### **Task 2. Identify Factors Influencing Implementation of Alternative Frost Control Measures.**

CLSI completed a summary report for this tasks that reviewed the physical processes causing frost conditions and the various methods for protecting crops from damage. The report also reviewed weather forecasting systems and the many different types of water supply used for frost protection in Napa County. This report also reviewed state water rights laws and the institutional barriers to revising water rights even when environmental improvements are the primary purpose for the change. A set of BMPs were prepared and have been incorporated into the Fish Friendly Farming program.

#### **Task 3. Identify Pilot Study.**

CLSI identified locations and methods for two pilot studies to assess feasibility of alternative frost control methods. CLSI prepared a summary report which discussed the two studies. One study would install subsurface drainage and sumps to recollect applied water in a variety of areas where water is used for frost control and soils are high in clay to determine if this practice is cost effective as water conservation BMP. The second pilot study would look at the challenges to creating a system of coordinated diversions between various landowners in a tributary basin. Pilot Study #2 requires stream flow monitoring, evaluation of fish habitats, determination of needed stream flow levels and a determination if coordination is needed to achieve these stream flow levels.

#### **Task 4. Develop Monitoring Protocols, including QAPP.**

CLSI prepared a stream flow gaging protocol and a QAPP for the protocol which was approved by EPA.

### FINANCIAL OVERVIEW OF EXPENDITURES

Task	Total EPA funds	Total Matching Funds*
<b>1. Perform Project Management.</b>	<b>\$7,500</b>	<b>\$0</b>
<b>2. Identify Factors Influencing Implementation of Alternative Frost Control Measures.</b>	<b>\$53,800</b>	<b>\$22,177.42</b>
<b>3. Identify Pilot Study.</b>	<b>\$28,800</b>	<b>\$2560</b>
<b>4. Develop Monitoring Protocols, including QAPP.</b>	<b>\$ 8,400</b>	<b>\$800</b>
<b>Total</b>	<b>\$98,500</b>	<b>\$25,537.42</b>

\* Required match was \$25,000

### LIST OF DELIVERABLES

Task 2 report - Protecting Instream Flows in the Napa River Watershed: Factors Influencing Implementation of Alternative Frost Control Measures

Task 3 report - Protecting Instream Flows in the Napa River Watershed: Pilot Studies

Task 4 report - Quality Assurance Project Plan for Stream Flow Monitoring and Coordinated Diversions Pilot Study

These three reports are attached.

### **LESSONS LEARNED FROM THE PROJECT**

The primary lesson learned is how difficult making changes to water rights can be even when the change does not directly benefit the landowner but instead is in the interest of environmental restoration.

The other major lesson learned is that in most locations stream flow monitoring and other basic hydrological monitoring is not occurring creating a lack of data and understanding of stream flow processes. This lack of data leads to difficulty in defining the primary problems which may be occurring in watersheds like the Napa River.

**PROTECTING INSTREAM FLOWS IN THE NAPA RIVER WATERSHED:  
TASK 2: FACTORS INFLUENCING IMPLEMENTATION OF ALTERNATIVE FROST CONTROL MEASURES**

Prepared by:

Laurel Marcus

Nelia White

Danielle D'Amour

California Land Stewardship Institute

Review and assistance from:

Peter Kiel, Ellison, Schneider & Harris L.L.P.

Paula Whealen, Wagner & Bonsignore Consulting Civil Engineers

Funding provided by:

The San Francisco Bay Water Quality Improvement Fund from the Environmental Protection Agency administered by the San Francisco Estuary Partnership and the Association of Bay Area Governments

## **INTRODUCTION**

Northern California wine country stretches from Mendocino and Lake Counties on the north to the Napa River and Sonoma Creek Valleys adjacent to San Francisco Bay. This region also supports three federally-listed threatened or endangered species – Chinook salmon, Coho salmon and steelhead trout. Irrigation water volumes used in wine grape vineyards are low, typically less than 0.7-0.5 acre feet (ac. ft.)/acre/year. High quality wines often use grapes grown using deficit irrigation, a technique which intentionally places the vine under water stress. In California’s Mediterranean climate, where the dry season coincides with the irrigation period, wine grapes are a low water use crop.

For parts of this winegrowing region, water is also used to protect new spring growth from freezing temperatures. Clear spring nights with dry weather can drop temperatures to freezing and the new buds on the grapevines can be burned and the entire crop lost. Some years, the number of frost nights is low. But a dry cold spring can bring numerous nights of frost and the need for frost control.

Frost control was done using smudge pots before electrical pumps and water systems were widely available. The smudge pots left smoke and air pollution in agricultural valleys and their use was restricted in the 1970’s. The replacement method developed was the application of water using sprinklers. The basic concept of frost control using water was developed by the University of California Extension Service and has allowed for the modern wine industry to expand to many locations. In Northern California, frost is only a concern following bud break, from about March 15 – May 15.

During a freeze, water is continually applied to the new growth on the vines. The volume of water used is high – up to 3,000 gallons/hour/acre, using standard overhead sprinklers. If frost events coincide with low rainfall and low stream flow, there is a potential for effects on salmonids.

The California Land Stewardship Institute (CLSI) is a non-profit organization that operates the Fish Friendly Farming Environmental Certification Program in Napa, Sonoma, Mendocino, and Solano Counties. The FFF certification is a comprehensive review of all aspects of an agricultural property which affect water quality, water flow and fish and riparian habitat. Both vineyards and wildlands are included in the review. CLSI works with the grower to produce a comprehensive Farm Conservation Plan. The plan is then certified by three regulatory agencies – National Marine Fisheries Service, Regional Water Quality Control Board and County Agricultural Commissioner. An FFF certification provides compliance under the Napa River and Sonoma Creek fine sediment TMDLs.

In addition to addressing fine sediment, the FFF program addresses stream flow, water sources and water rights on each property.

This project, funded by the Environmental Protection Agency (EPA) through a grant to the San Francisco Bay Estuary Partnership and the California Land Stewardship Institute, focuses on the Napa River Watershed, a major tributary to San Pablo Bay, which supports steelhead trout and Chinook salmon. This report summarizes the results of the following task:

### **Task 2 Identify Factors Influencing Frost Control Implementation Measures**

Under this task, frost severity zones were determined and alternative frost control measures were identified. These measures were discussed with numerous grape growers. Under this task, technical

and institutional issues which influence the implementation of alternative frost measures were identified and discussed.

Two other tasks are included in the project and will be summarized in separate reports:

**Task 3 Identify Pilot Study**

This task involved identifying locations and methods for a pilot study to assess the feasibility of specific alternative frost control methods.

**Task 4 Develop Monitoring Protocols, including a Quality Assurance Project Plan (QAPP)**

This task would identify monitoring protocols for parameters related to the frost issue and involve growers in developing the protocols.

**BACKGROUND: WATERSHED PROCESSES**

The Napa River Watershed encompasses 426 square miles at its confluence with San Pablo Bay (Figure 1). Mountains stretch from northwest to southeast enclosing the sides of the Napa Valley. The Napa Valley was formed through movement along faults and uplift of the mountains with widening and dropping of the valley floor. As the mountains eroded, the valley filled with the eroded material or alluvium.

Both the climate and geology of a watershed are major determining factors in the timing and magnitude of stream flow. The Napa watershed averages 25 inches of rainfall each year limited to the wet season of October to May. The Napa River Watershed is made up of older sedimentary rock- Franciscan Formation and Great Valley Complex as well as younger volcanic rock – the Sonoma Volcanics. Sonoma Volcanics make up the mountains along the eastern and northwestern edges of the drainage. This formation is water bearing and in some locations springs are numerous (Spring Mountain).

Along the western and southwestern side of the watershed, sedimentary rock of the Franciscan Formation and Great Valley Complex occur. Franciscan Formation consists of an ancient seafloor, which has been crumpled by tectonic processes to form the coastal ranges. Neither the Franciscan Formation nor the Great Valley Complex are water bearing in most locations. The alluvium which fills the valley makes up the largest groundwater basin (Figure 2). The depth of the alluvium varies over the valley and at a 200 ft depth is estimated to hold 300,000 ac. ft. of water (Kunkel and Upton 1960).

The Napa River Watershed has numerous small creeks and a few large tributaries. There are a number of large municipal reservoirs in the drainage including: Kimball Reservoir on the Upper Napa River, Bell Canyon Reservoir on Bell Canyon Creek, Lake Hennessey on Conn Creek, Rector Reservoir on Rector Creek and Milliken Reservoir on Milliken Creek. These reservoirs are on the eastern side of the drainage and do not have established dry season releases.

The headwaters of most tributary creeks occur in the mountains. Most creeks course through a rocky canyon before spilling out onto the valley floor. At the canyon outlet, the creek may deposit a cone of boulders, gravel and sand called an alluvial fan. Some of the tributaries such as Dry Creek have very

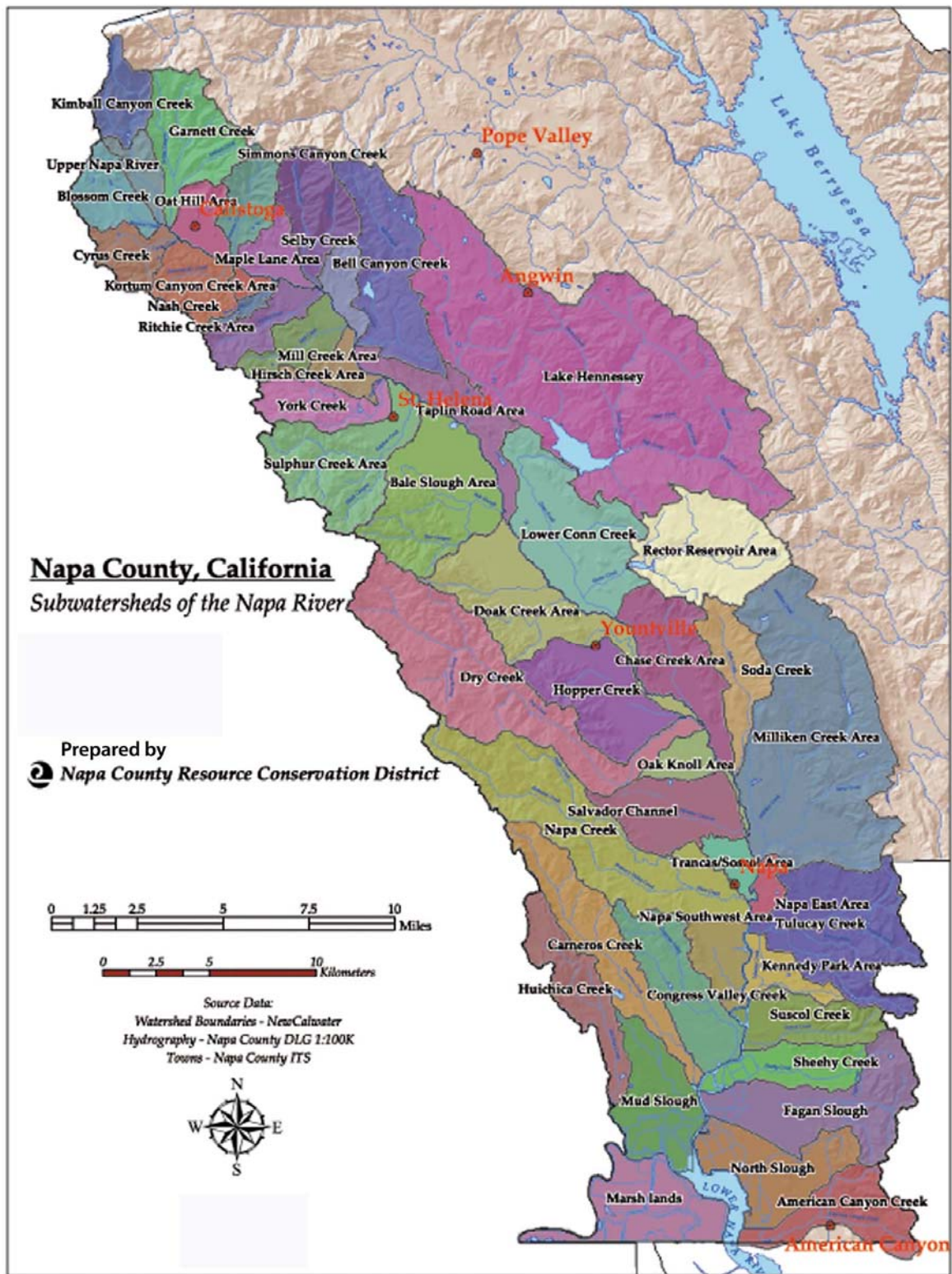

Figure 1. Tributary Watersheds of the Napa River Watershed



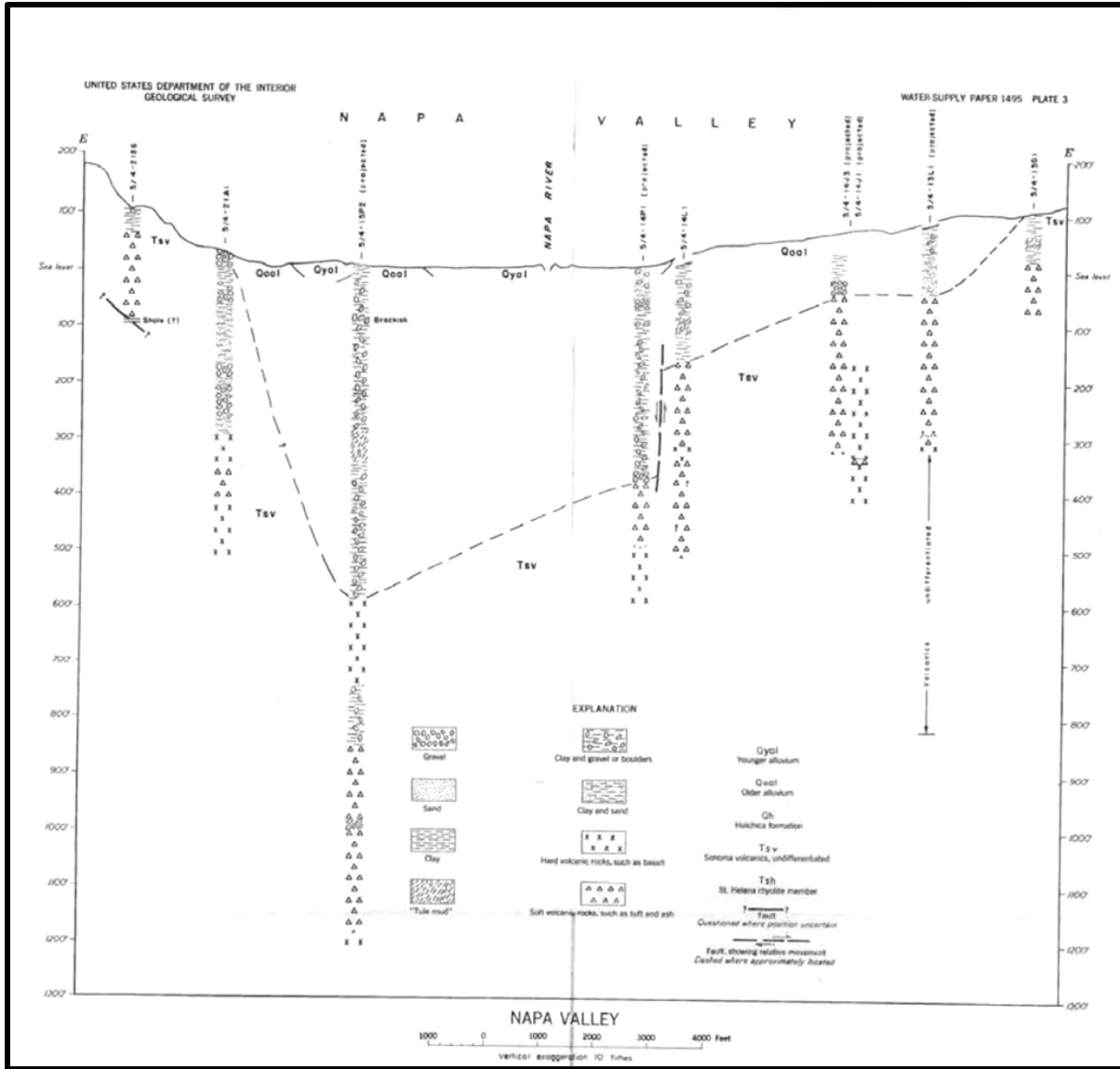

Figure 2. Cross Section of the Napa Valley showing Alluvial Basin

From: Kunkel, Fred and J. E. Upton. 1960. Geology and Groundwater in Napa and Sonoma Valleys, Napa and Sonoma Counties, Ca. U. S. Geological Survey Water Supply Paper 1495

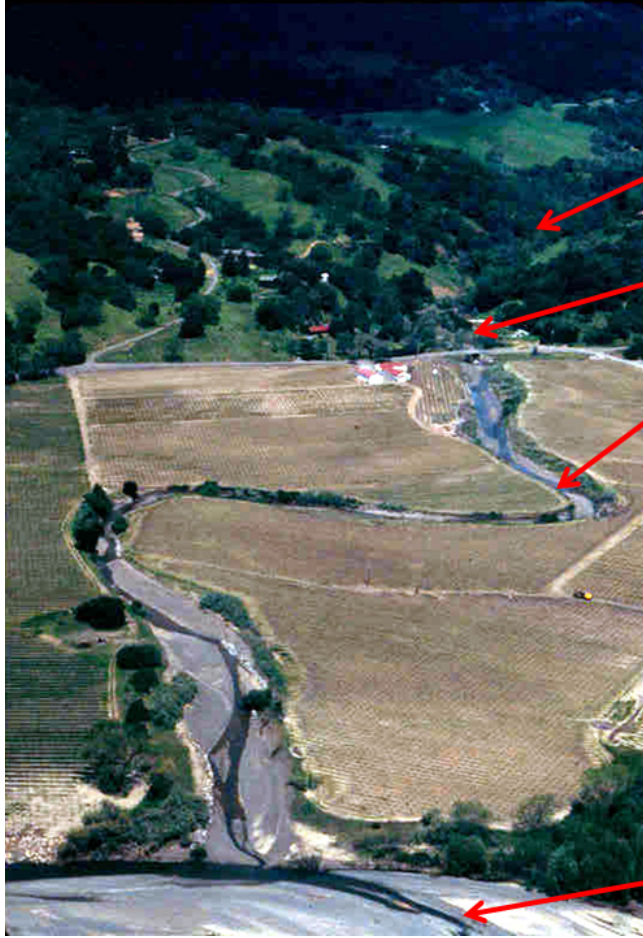

Figure 3. Types of Stream Channels

Creek channel in bedrock canyon

Alluvial fan

Alluvial creek channel

River channel in alluvial valley

large alluvial fans which actually restrict the Napa River from meandering towards the west. Downstream of the alluvial fan, the creek crosses the valley floor to reach the river (Figure 3).

Stream flow processes differ significantly between the rocky canyon, the alluvial fan, and the alluvial valley reach of the creek. In the canyon reach, adequate rainfall is needed to saturate the surrounding watershed and initiate runoff during the rainy season. Some flow will infiltrate into the streambed but most moves as surface runoff to downstream areas. In the alluvial fan reach where the stream flow passes over the highly porous, large cobble at the head of the fan, the water percolates. Stream flow from tributary creeks percolates into the alluvium of the valley at the beginning of the rainy season. As the valley's groundwater basin fills with water up to the elevation of the stream and river channels and more runoff occurs, continuous stream flow occurs between the river and the alluvial and canyon reaches of the creek.

The alluvial reach and alluvial fan may have intermittent flow even in the winter, if periods of dry weather occur. Several changes in the Napa River Watershed further affect the timing of stream flow in the alluvial and alluvial fan reach. The large municipal reservoirs can affect the timing and magnitude of stream flow, particularly in the early part of the rainy season, and in low rainfall years. All of these reservoirs function primarily to impound water until full and then water is released to the downstream creek. In a dry year, some creeks never receive flow from the reservoir. It is also likely that the reservoirs, by reducing downstream contributions to filling the alluvial basin, affect the timing of stream flow in the river and other creeks.

Due to the effects of the large reservoirs on reducing sediment supply to the river and several other factors, the Napa River has incised 12-15 feet (Stillwater Sciences 2002), meaning the elevation of the bottom of the channel has dropped, thereby dropping the low point in the alluvial valley (Figure 4). During low rainfall years, if river flows are low, creek flows may infiltrate into the valley alluvium with little connected surface flow. The incised river channel steepens the slope between the alluvial fan and the river channel, causing stream flow to infiltrate until river levels rise; reduce the slope and surface stream flow can occur (Figure 5). When considering the effect of agricultural diversions on instream flow, these other facilities also have to be taken into account. The processes of generation and maintenance of stream flow in the watershed provide instream habitats for salmonids and these processes are affected by more than agricultural diversions for frost control.

### **FROST CONTROL PRACTICES IN VINEYARDS**

In the Napa Valley, spring can bring freezing temperatures after grapevines have budded out. These frosts will burn tender vegetation and damage the plant if no protection measures are taken. Frost conditions come from two different types of climatic events. Advection frost occurs when a large mass of arctic air occupies the valley, creating frost conditions on both the valley floor and hillsides (Snyder 2001). The frost season of 2008 included an advection frost event on April 20-21.

More common are radiation frost events. In these events, cold air pools at the lowest points in the valley, along tributary creeks, and in hollows. Above this layer of cold air, a warmer air mass may be present, creating a strong inversion layer. If the difference in air temperature between the valley floor and upper layers is small, this is a weak inversion layer. Radiation frost events are also marked by clear skies and calm winds. Radiation frost events occur in the valleys and low hollows of the Russian River watershed on a frequent basis. Only frost events that occur during and after grape bud break are of concern to farmers. This is usually the March 15 to May 15 period. Typically vineyards and orchards on

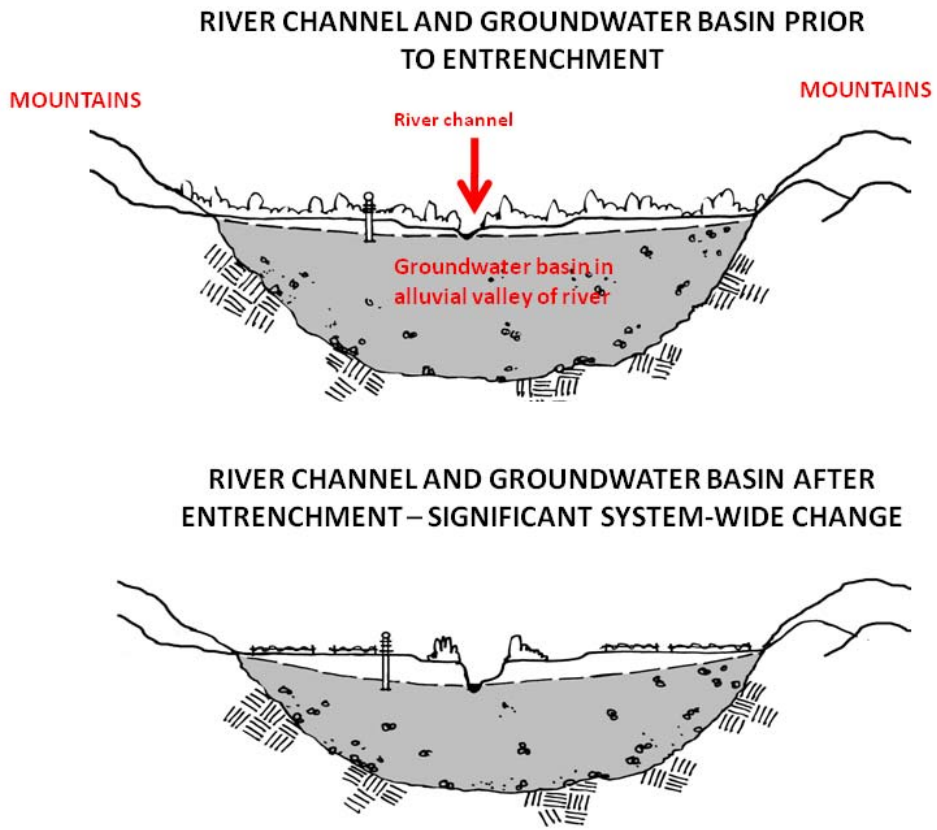

**Figure 4. Effects of River Channel Entrenchment on Groundwater Levels in Alluvial Basins**

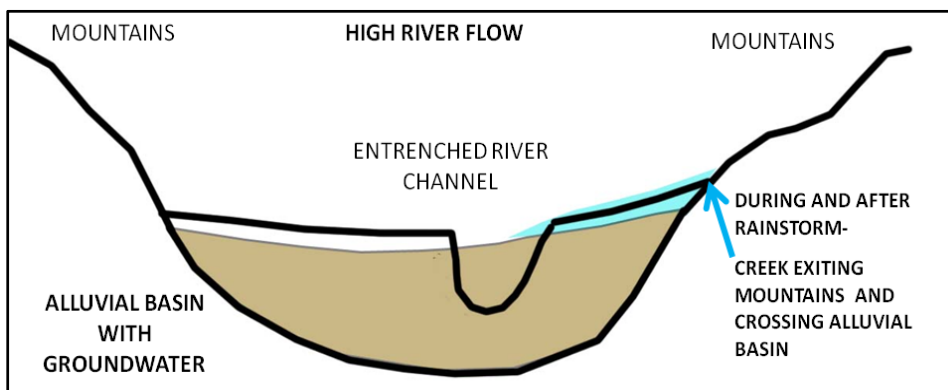
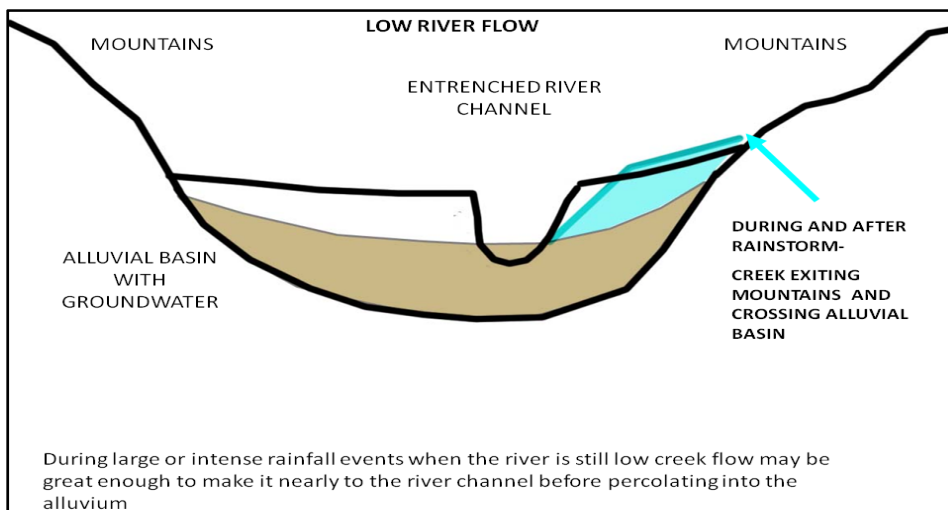
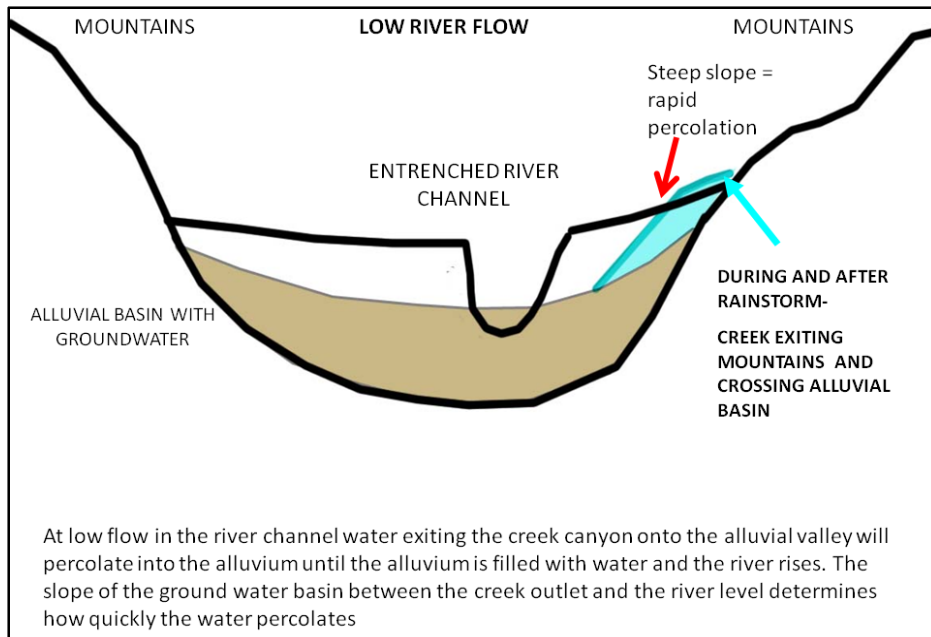

**Figure 5. Illustration of the Effects of Main River Channel Entrenchment on the Timing and Magnitude of Tributary Stream Flow**

the valley floor and in hollows or low spots in the hilly areas require frost protection. Most hillside vineyards do not need frost protection due to the infrequent occurrence of advection frost.

In order to understand frost control measures, it is essential to understand the physical processes that occur during a radiation frost event. During a radiation frost event, more energy is lost to clear, cold skies from the vines than is gained. Cloudy or windy conditions may have adequate energy transfer to avoid energy loss from the vines. Typically there are several types of energy transfer:

- **Conduction** is the transfer of energy through objects that don't move. Soil heat moves through conduction.
- **Convection** is the transfer of heat in moving air.
- **Radiation** is the transfer of electromagnetic energy such as sunlight. Crops radiate energy as does the atmosphere.
- **Latent heat** is the energy stored in the bonds that join water molecules together. For example, when water changes form from a liquid to a solid state, the environment around the water changes temperature due to the change of the latent heat in the water to sensible heat. Sensible heat is measured with a thermometer and is "sensed" by us. When water changes from liquid to a solid, the localized air temperature rises. When water changes from a liquid to a vapor state, the localized air temperature falls. This cooling effect of evaporating water is the principle used by swamp coolers. Similarly, there is a warming effect of freezing water.

One of the physical factors besides air temperature that determines frost effects is humidity. Humidity plays a major role in frost events. Humid air, or air with high water vapor content, has higher energy content than dry air, due to the increase in air temperature produced when vapor condenses or changes to a liquid form (Snyder and de Melo-Abreu 2005).

The severity and timing of a frost event is affected by both the air temperature and the timing of freezing temperatures (32°F or 0°C), as well as the dew point or temperature (DPT) at which water vapor condenses to liquid or dew. The wet bulb temperature (WBT) is another important measure and is the evaporatively cooled temperature of a moist surface in a given air mass. WBT is approximately halfway between ambient air temperature and dew point temperature (Snyder 2000).

During very low humidity conditions, damage to vines may occur before freezing temperatures (32°F or 0°C) occur. For this reason, air temperatures, dew point, and wet bulb temperature must be monitored to determine when to begin frost prevention measures.

Water freezes onto plants more readily if ice-nucleating bacteria are present. The bacteria act as surface particles that make it easier for ice crystals to form. These bacteria have the greatest effect in the range between 23°F to 32°F (-5°C and 0°C). Spraying anti-bacterial copper or introducing competing bacteria that do not nucleate ice can reduce the number of ice-nucleating bacteria.

For most of the valleys where grapes are grown, frost control is essential to avoid major damage and loss of both a year's crop and sometimes the vines themselves. Vineyards on hillsides or near the coast or San Francisco Bay typically do not have frost problems or require frost protection most of the time.

In the Upper Napa River watershed, Pope, Chiles, and Wooden Valleys, springtime temperatures can become very cold (27°F or -3.9°C wet bulb temperature) and these areas are in a severe frost zone. Other areas of the Napa River watershed are a moderate frost zone (28-30°F or -2.2°C wet bulb

temperature). The lower Napa River watershed have mild frost events (31-32°F or -0.5 – 0.0°C wet bulb temperature) due to the moderating effect of San Francisco Bay (CIMIS, NCDC).

Small topographic changes between the low-lying areas of a valley and adjoining lands can create different levels of severity in frost events and require different frost prevention methods.

Temperature monitoring in the vineyard is the only way to determine what frost prevention methods can be used. Detailed weather forecasts, particular for local areas, can provide important information on whether freezing air temperatures and low dew point temperatures will occur, where they will occur on a local basis, and what time of day or night critical temperatures will occur. But site specific air temperature and wet bulb temperature monitoring are needed to determine when frost prevention measures should begin for a particular location.

**Table 1. Seasonal Bud Break by Grape Variety**

Grape variety	Seasonal date of budbreak
Chardonnay	Early
Pinot noir	Early
Gewürztraminer	Early
Pinot gris	Early
Petite Sirah	Middle
Merlot	Middle
Zinfandel	Middle
Syrah	Middle
Viognier	Middle
Sauvignon blanc	Middle/Late
Cabernet Sauvignon	Late

**Table 2. Frost Zones and Estimated Annual Maximum Hours of Frost Control**

Severe	Maximum hours	Moderate	Maximum hours	Mild	Maximum hours
Upper Napa Valley	50-70	Mid Napa Valley	35	Lower Napa Valley	20
Pope Valley	100			Suisun Valley	20
Chiles Valley	100				
Wooden Valley	50-70				

Weather stations supplying relevant climate data in Napa are separated into public access and private access. The networks of stations are listed below, with the typical data that is available from them.

**Public Weather Data Networks**

Public weather networks in Napa are depicted in Figures 6, 7 and 8 and include:

**California Irrigation Management Information System (CIMIS):** This network of over 120 automated weather stations is a program of the Office of Water Use Efficiency, California Department of Water

Resources developed in conjunction with UC Davis in 1982. The purpose of the CIMIS is primarily to aid in irrigation scheduling. The variables measured include air temperature, relative humidity, wind speed and direction, and precipitation; dew point temperature is calculated from relative humidity and air temperature. Hourly, daily, and monthly data reports are available.

**Cooperative Observer Program (COOP):** Created in 1890, this large volunteer network of cooperative stations is supported by the National Weather Service (NWS) and data is sent to the **NCDC**, National Climatic Data Center, where it is checked and archived. COOP stations have an NCDC ID number.

**Hydrometeorological Automated Data System (HADS):** This is a real-time data acquisition and data distribution system run by the Office of Hydrologic Development of the National Weather Service. The data values on HADS are provisional and have not been evaluated through quality control tests. Data are gathered in hourly intervals for temperature and precipitation.

**Automated Surface Observing Systems (ASOS):** A joint program of the National Weather Service, the Federal Aviation Administration, and the Department of Defense, these more than 900 airport stations transmit data hourly for air temperature, dew point, pressure, wind speed and direction, gusts, and minimum/maximum temperature over 6 and 24 hour periods. The data are reliable, although the stations are dispersed, so there is only one in Napa.

**Citizen Weather Observer Program (CWOP):** In this private-public partnership (formerly called APRSWXNET), citizen maintained weather stations upload data to a NOAA server, where they are checked for data quality, then redistributed. The data are used by over 500 organizations including Weather Underground and the NWS Weather Forecast Offices. Current data for temperature, wind speed, direction and gusts, dew point, relative humidity, pressure, and precipitation are available online through MesoWest at the University of Utah.

### **Private Weather Data Networks**

Napa Valley also has private weather networks, four of which are listed below.

**Ranch Systems** provides a network of sensors and telemetry, and a frost alert system. Data provided include temperature, humidity, wind speed, radiation, precipitation, and soil moisture.

**Precision Forecasting**, has 11 stations listed for Napa County including: Pope Valley, Angwin, Stagecoach, Calistoga, St. Helena, Rutherford, Oakville, Yountville, North Napa, SE Napa, and Carneros. This system provides daily climate data and five-day forecasts, including specific forecasts for six microclimates in Napa County and frost reports.

**Picovale Services, Inc.** Picovale Services provides an online weather monitoring and alerting services; variables monitored include air temperature, relative humidity, wind speed, soil moisture, and precipitation (see Figure 9, about 18 sites in Napa Valley and 5 in Pope Valley).



**Table 3. Public Network Weather Stations in Napa County**

<b>Network</b>	<b>Station Name</b>	<b>Station #</b>	<b>Elev (ft)</b>	<b>Active</b>	<b>Start</b>	<b>End</b>
CIMIS	Angwin	079	1720	N	5/11/1989	12/27/1996
COOP	Angwin Pacific Union College	040212	1715	Y	4/1/1952	1/17/2009
HADS	Angwin Pacific Union College	ANGC1	1715	Y	12/16/2006	now
COOP	Calistoga	041312	370	Y	11/1/1916	1/1/2009
CIMIS	Carneros	109	5	Y	3/11/1993	now
CWOP	CW4897 Napa	C4897	110	Y	1/4/2006	now
CWOP	CW5671 Pope Valley	CW5671	500	Y	4/5/2006	now
COOP	Dutton's Landing	042580	20	N	11/1/1955	7/1/1977
COOP	Napa	046065	20	N	12/1/1903	1/1/1919
HADS	NAPA 9NNE	NAPC1	1660	Y	12/16/2006	now
CWOP	AA6AV-10 Napa	AS725	79	Y	9/13/2007	now
ASOS	Napa County Airport	KAPC	33	Y	4/12/1997	now
COOP	Napa County Airport	046066	14	Y	9/1/2000	now
COOP	Napa State Hospital	046074	35	Y	1/1/1893	now
CIMIS	Oakville	077	190	Y	3/1/1989	now
COOP	Oakville 1 W	046351	171	N	4/1/1906	7/1/1914
COOP	Saint Helena	047643	230	Y	1/1/1931	now
COOP	Yountville	049859	95	Y	11/11/2002	now

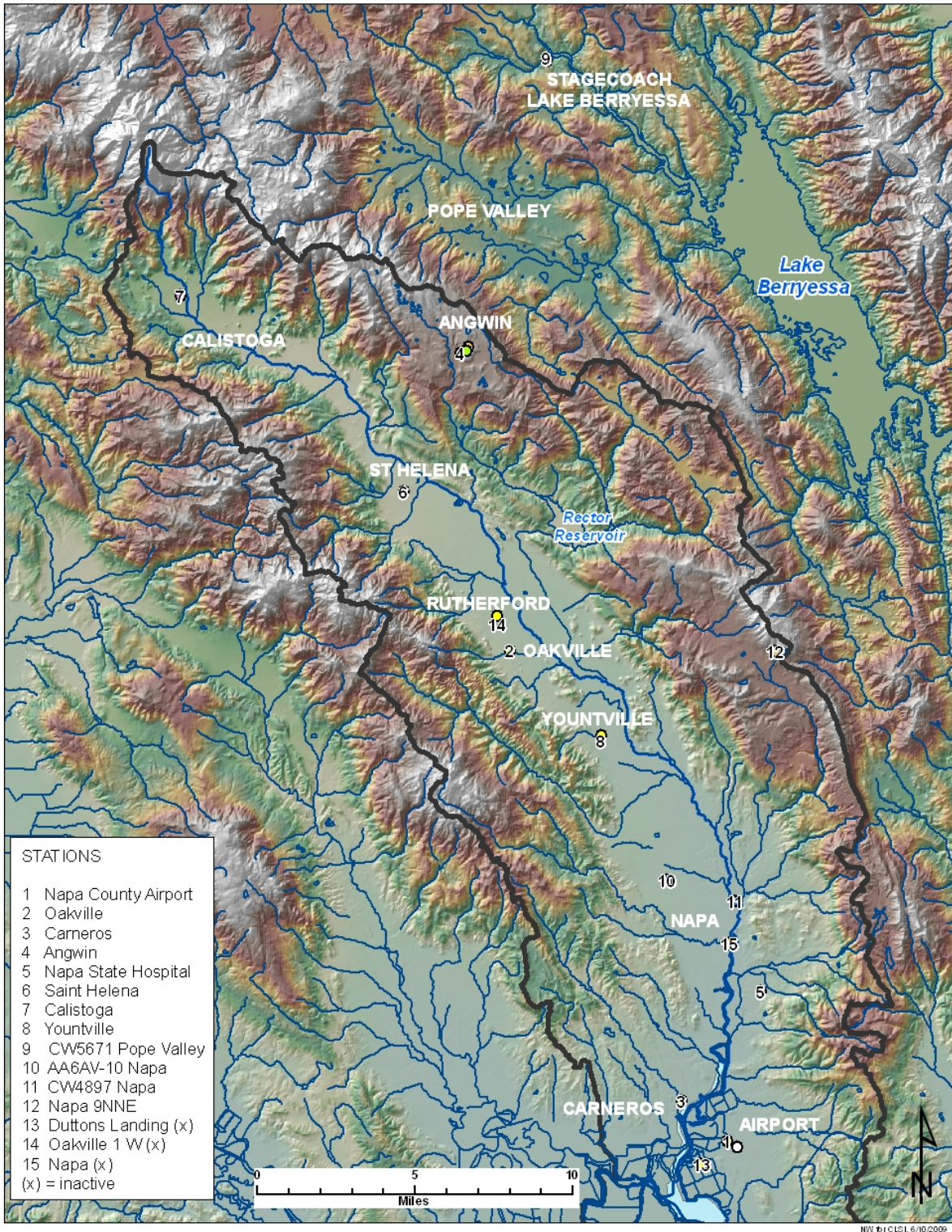

**Figure 6. Public Weather Stations in Napa Valley by Name**

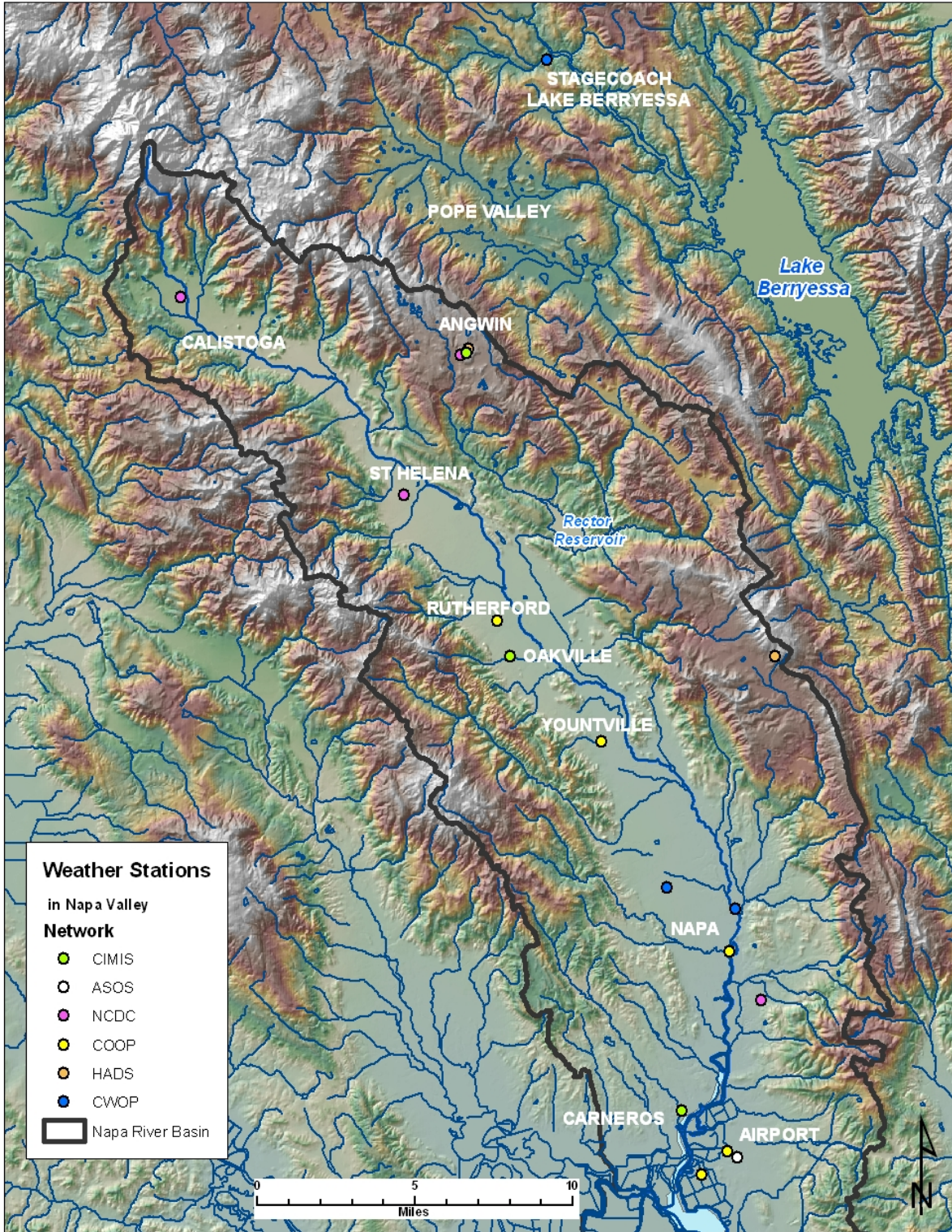

Figure 7. Public Weather Stations in Napa Valley by System



### How to Manage Pests California Weather Data

[Weather menu](#) | [Station news](#) | [About the database](#) |

## Napa County Weather Stations

View:  map with stations  map only

Click on a station name or pinhead for more information.

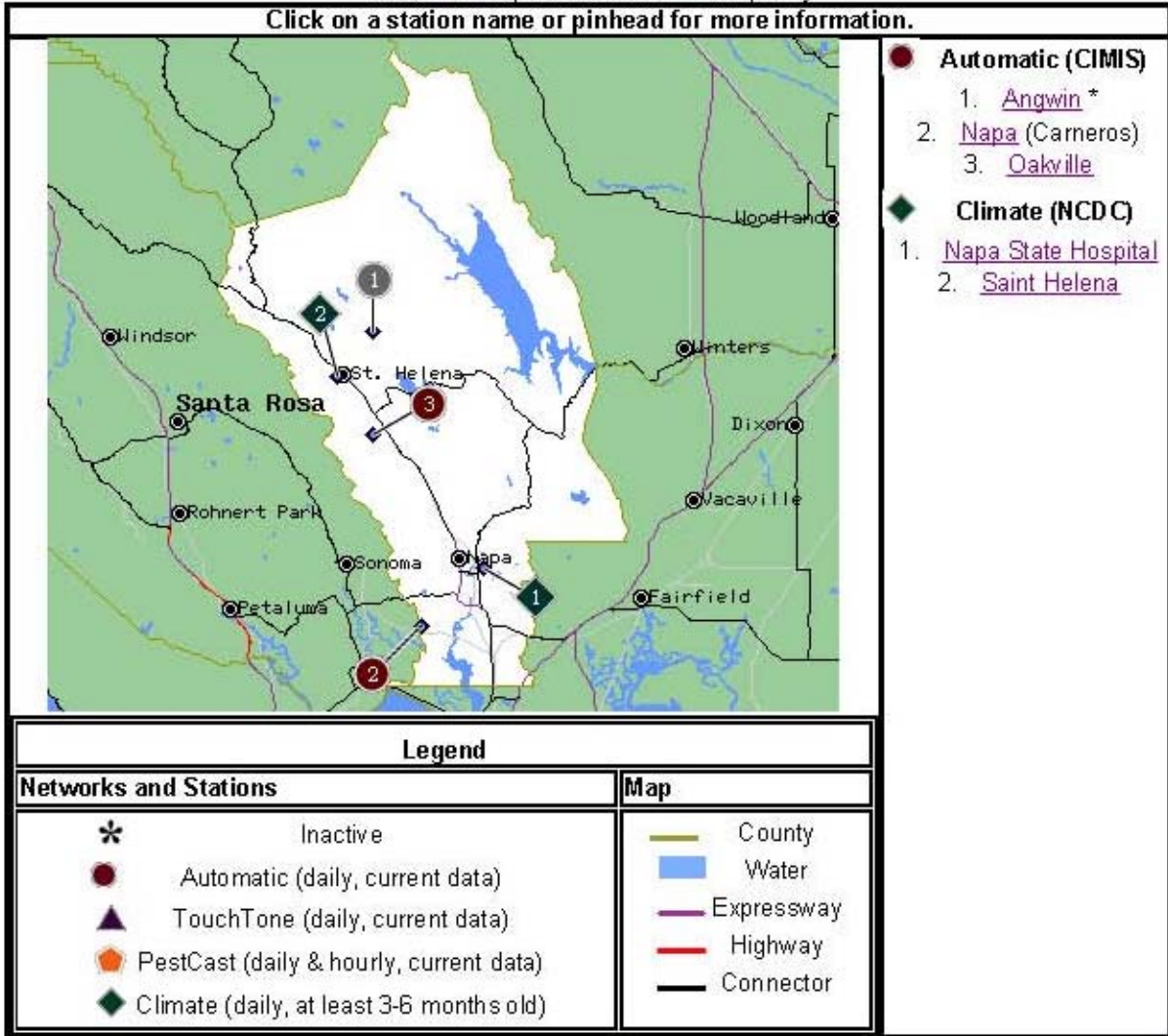

- Automatic (CIMIS)
  1. [Angwin](#) \*
  2. [Napa](#) (Carreros)
  3. [Oakville](#)
- ◆ Climate (NCDC)
  1. [Napa State Hospital](#)
  2. [Saint Helena](#)

Statewide IPM Program, Agriculture and Natural Resources, University of California  
All contents copyright © 2003 The Regents of the University of California. All rights reserved.

For noncommercial purposes only, any Web site may link directly to this page. FOR ALL OTHER USES or more information, read [Legal Notices](#). Unfortunately, we cannot provide individual solutions to specific pest problems. See [How to manage pests](#), or in the U.S., contact your [local Cooperative Extension office](#) for assistance. [WEATHER/SITES/napa.html?printpage](#) revised: December 17, 2003. [Contactwebmaster](#).

Figure 8. CIMIS and NCDC Stations in Napa County

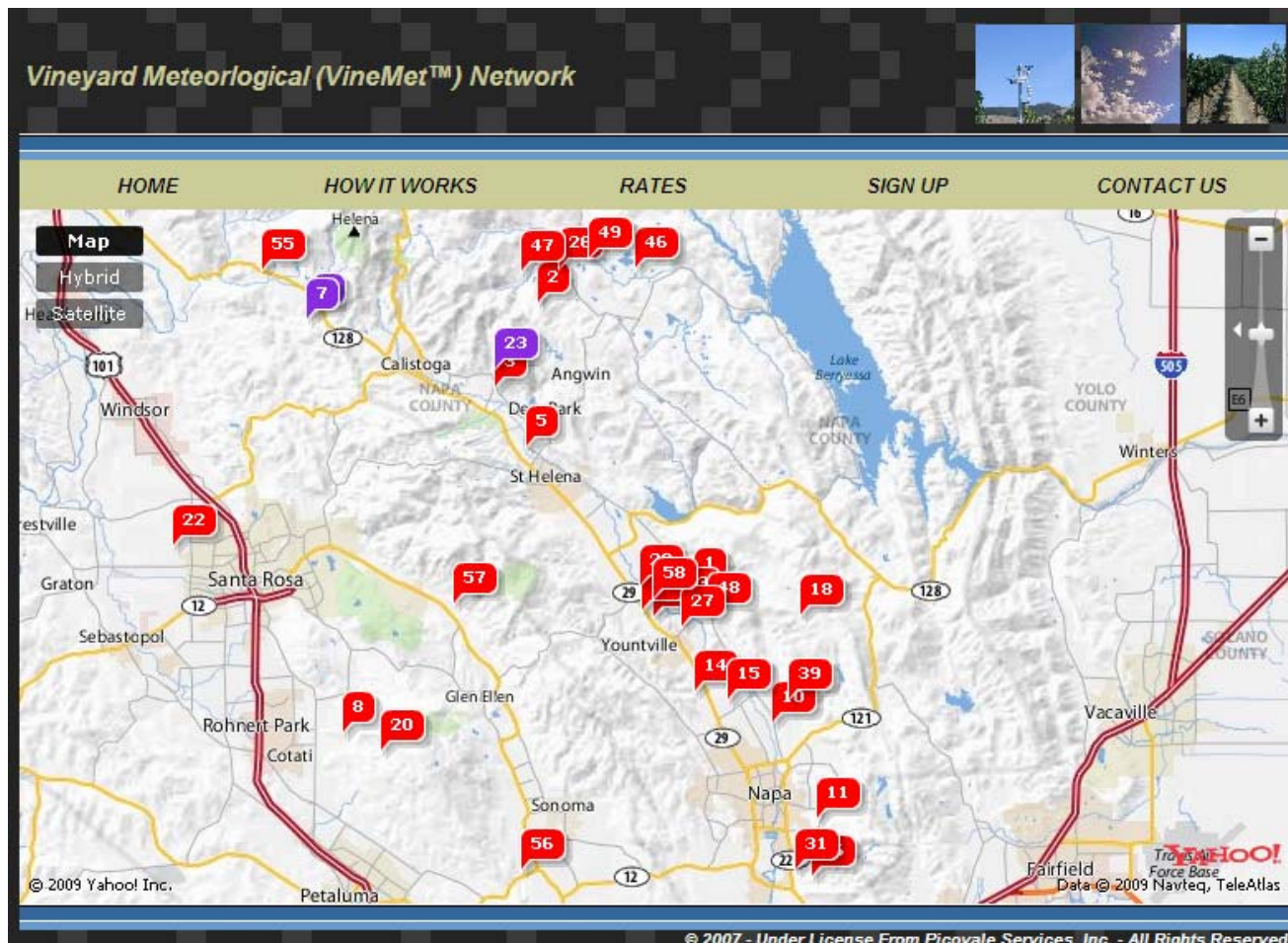

**Figure 9. Picovale Weather Services/ VineMet Map of Napa County Weather Stations**

Terra Spase using ADCON telemetry was one of the first private weather networks of ADCON in Napa and Sonoma counties, providing climate data, including temperature, relative humidity, precipitation, leaf moisture, and solar radiation at fifteen-minute intervals with data summaries, available for download and manipulation with proprietary software. Terra Spase also provides maps of minimum temperatures (see Figure 10, 17 stations in Napa County).

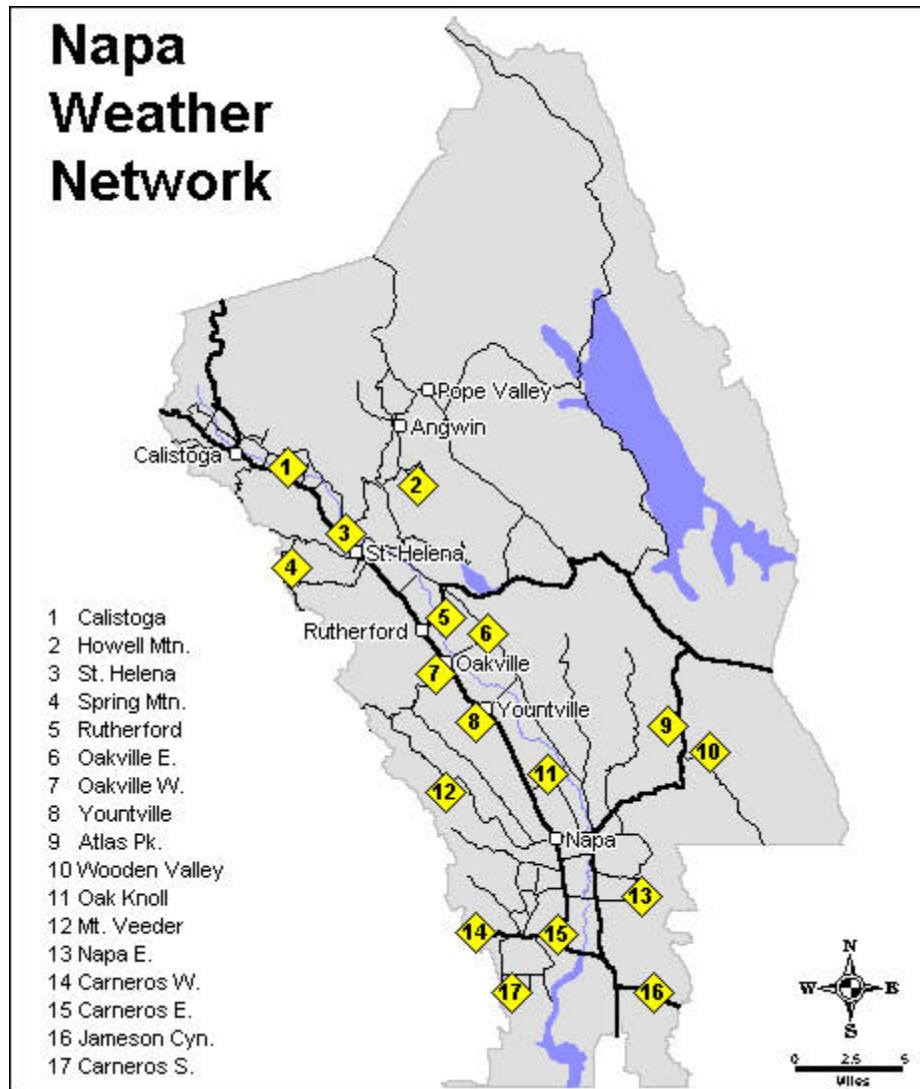

**Figure 10. Terra Spase Map of Napa County Weather Stations**

## Water Demand Management Measures

There are a number of practices which can reduce the amount of water needed for frost control.

### **Passive Frost Control Measures**

There are a number of passive measures that can be implemented to reduce frost damage in vineyards. These are cultural measures which can allow for lower temperatures to occur without damaging vines. These measures used alone can be adequate in areas with very little frost risk. They can also be incorporated into a program which includes active measures. Passive frost control measures include:

- **Site selection.** Some varieties of grape vines bud later in spring and will require less frost protection. Chardonnay is an early budding variety, while Cabernet is not. If the soil and climate are appropriate, the lowest-lying valley areas can be planted or replanted to the later-budding grape variety to reduce water use.
- **Increase cold air drainage** out of the vineyard. The row orientation and location of ornamental vegetation around the vineyard may be modified to allow for cold air moving to lower areas to drain rather than pool in the vineyard.
- **Restrict cold air movement** into the vineyard. For low-lying sites, row orientation and bordering vegetation can be used to block cold air moving into the vineyard, thereby limiting damage or active control measures to the outer vineyard edge.
- **Late pruning.** By pruning grapevines later (early March), the onset of budding can be delayed and the need for frost control can be delayed.
- **Cover crop and vineyard floor management.** Cover crops are required during the rainy season, but they need to be managed to reduce frost problems. Decisions on what type of vineyard floor management is needed should consider if a drought is occurring and the level of frost risk for a particular site. Cover crops reduce the amount of heat absorbed by the soil. Cover crops also host ice-nucleating bacteria, which can increase frost damage. Mowing cover crops and strip-spraying with herbicides can reduce some of the negative effects of cover crops during frost events. Disking and rolling the soil surface is also suggested by some experts to increase solar radiation inputs into the soil, which will then radiate heat into the crop during nighttime hours. This practice can result in soil erosion and should only be used in dry years when water supplies are low. Vineyards with cover crops can be 1 to 3°F (0.5 to 2.0°C) colder than vineyards with mowed and disked cover crops.
- **Copper applications.** Copper sulfate is a commonly used, organically-certified fungicide. Copper applications can kill ice-nucleating bacteria and therefore reduce frost damage in marginally frost-prone areas and on nights with low, but not extremely low temperatures. Care in the application process is needed to avoid any drift of copper spray, any rinse-off, and any soil erosion as copper binds to soil particles. Copper is acutely toxic to aquatic organisms. Copper applications are known to allow for 1-1.5°F (0.5 to 1.0 °C) colder conditions without damage than on vines without copper.

- **Frost Gard, Frost Shield, Extol Sprays.** These sprays claim to provide protection to vegetation down to -2°F (28.4°F) but must be applied 24 to 10 hours before frost event and must completely coat the vegetation. The Frost Shield spray is a micro-thin protein pro-polymer and Frost Gard is a systemic/contact nutritional spray. Extol is a kelp derived material.
- **Risk management.** The risk of frost damage in mild frost areas may be low enough that only passive measures are needed.

### Active Frost Control Measures

There are a few active frost control techniques currently in use – wind machines, diesel heaters, and water (Figures 11 and 12).

**Wind machines** have a limited application, depending upon the vineyard location. Most wind machines are a large horizontal fan that stirs up air masses, mixing the cold air near the ground with warmer layers above. In areas with marine influence, or certain microclimates, wind machines can work to prevent frost damage. However, in many interior valleys, the air layers above the ground are also at freezing temperatures, so mixing the air masses is not effective. Another type of wind machine is a Selective Inverted Sink (SIS), which is a fan oriented parallel to the ground and housed in a small tower. The fan, which is close to ground level, shoots cold air upward and draws warm air to the ground. Generally wind machines can provide frost protection down to 29°F (-1.6°C) and can only work where an inversion layer occurs at 6 to 50 feet above the ground and is at least 2.7°F (1.5°C) warmer than the ground layer air.

**Vineyard Heaters.** Diesel fuel heaters were once in common use for frost protection. In a few areas, diesel vineyard heaters may still be used, but most growers stopped using them in the 1970s due to the air pollution problems they create.

**Water.** In colder areas with moderate to severe frost conditions, water is the only frost control measure. The concept behind this technique is based on the latent heat released as water moves from a liquid to solid state. By continuously applying water to the vineyard, the water changing from a liquid to a solid state on the vines creates heat and protects the vegetation from frost damage. Use of water can protect against temperatures of 27°F (-2.7°C) but will not work at 24°F (-4.4°C).

There are several different types of sprinklers in use for frost control in vineyards:

- **Standard size overhead sprinkler system** emit 50 gallons/minute/acre or 3,000 gallons/hour/acre. These are rotating head sprinklers, which wet the entire vineyard canopy and vineyard floor. They typically rotate every 30-60 seconds and 25-30 sprinklers are needed per acre regardless of the vine spacing or trellis type. A minimum of 0.1 inches of water must be applied per hour. Within the vineyard, these sprinklers have a separate system of water pipes than the drip-irrigation system.
- **Low-flow overhead sprinklers** emit 35-40 gallons/minute/acre or 2,400 gallons/hour/acre. These are also rotating head sprinklers, but wet a smaller area. These sprinklers are used at the same density as the standard overhead sprinklers. In vineyards with dense spacing standard sprinklers should be used. These sprinklers also run off a different set of waterlines than the





**Standard Overhead Sprinklers**



**Low Flow Sprinklers**

**Figure 11. Types of Sprinklers**



**Figure 12. Types of Wind Machines**

irrigation system. If water availability is a limiting feature spacing the vines to be able to use these sprinklers may be advantageous. A new low flow sprinkler the LF 1200 series is able to produce the needed coverage of the vines with less water. The gallons per minute use rate ranges from 1.5-2.0 for a rotation time of 60 seconds.

- **Micro-sprinklers** are of two types: pulsating and constant. Both types operate as part of the drip-irrigation system. The micro-sprinklers are placed in the vine canopy and have a localized effect. To provide adequate frost protection there needs to be 280-400 micro-sprinklers/acre. Pulsating micro-sprinkler systems use 12-20 gallons/minute/acre or up to 1,200 gallons/hour/acre. Micro-sprinklers with constant water output use 25-35 gallons/minute/acre or up to 2,100 gallons/hour/acre. Micro-sprinklers do not work in divided canopy trellis systems; they work only in single canopy systems.

There are several considerations in choosing one type of sprinkler over another. Areas with severe frost events, such as the Upper Napa Valley or Pope Valley, can theoretically use micro-sprinklers as long as the system is turned on several hours earlier than standard set systems. However, there are many growers who have had problems with the small water lines of micro-sprinklers freezing in severe frost zones. It is not clear why these problems have occurred and if improved management with the micro-sprinklers would prevent frost damage in these vineyards. Another consideration is the vine-row spacing. In densely planted vineyards, the number of micro-sprinklers needed and the water use can exceed standard set sprinklers.

A final consideration is the method of harvest used. Machine harvesters are often used on flat ground in valley areas also typically frost-prone. Prior to harvest, all types of sprinklers have to be removed and then reinstalled prior to spring. Micro-sprinklers can be very labor intensive to remove and re-install due to their numbers in the vineyard.

### **When to Turn on the Sprinklers**

Determining when to turn on the sprinklers on a frost night will partially depend on the type of sprinklers used. For all systems, several types of temperature monitoring in the vineyard are needed.

Even if accurate localized weather forecasts are available, conditions in the vineyard's most frost-prone areas have to be monitored. Standard set sprinklers need to be turned on when the wet bulb temperature is above the critical damage temperature for the crop. For grape vines, the critical damage temperature is 31.5°F for 30 minutes. Micro-frost systems need to be turned on several hours earlier than standard sprinklers. Under low dew point temperatures (a very dry cold), sprinklers need to be turned on earlier than under higher dew point temperatures for the same air temperature. Under low dew point temperatures the wet bulb temperature is lower than the air temperature and, when the sprinklers are turned on the water reduces air temperatures to the wet bulb temperature and frost damage can occur. For this reason, sprinklers must be turned on early.

Wet bulb temperatures can be measured directly or determined from measurements of the dew point or relative humidity and air temperature. A wet bulb temperature above 31.5°F, the critical damage temperature for grapes is selected. Using Table 4 the selected wet bulb temperature, and measured/predicted dew point can be selected and the air temperature for standard sprinklers turn-on can be read. If relative humidity and temperature are known, Table 5 can be used to determine dew

point temperature for use in Table 4. Direct measurements of wet bulb temperature in the vineyard allow for different types of sprinklers to be turned on at the needed time before the critical damage temperature will occur.

Wet bulb and dry bulb temperature can be measured in the vineyard with a manual instrument called a sling psychrometer or a digital version. The digital version, if fixed to a location in the canopy of the low part of the vineyard, often has the ability to be read remotely by a computer or cell phone. A network of instruments can give the greatest coverage and determine the need to turn on the sprinklers most accurately.

Water is continuously applied to the vines during frost events. As the water is applied and it freezes, it releases heat, warms the leaves, but then the temperature drops to the wet bulb temperature as evaporation occurs. If the leaves are not wetted again immediately, frost damage will occur. Therefore, the interval between water applications is critical to avoiding damage. This interval is the sprinkler rotation rate, which for standard overhead sprinklers is typically 30 seconds, but may be as long as 60 seconds. The entire bud/leaf/stem area needs to be covered on each rotation. Table 5 lists the water volumes applied for 30 or 60 second rotation sprinklers at various temperatures and wind speeds. The water is turned off when the air temperature and the wet bulb temperature are above 32°F (0°C). It is not necessary to wait for all the ice to melt.

**Table 4. Minimum Turn-On and Turn-Off Air Temperatures (°F) for Sprinkler Frost Protection for a Range of Wet-Bulb and Dew-Point Temperatures (°F)\***

Dew-point											
Temperature		Wet-bulb Temperature (°F)									
°F	22	23	24	25	26	27	28	29	30	31	32
32											32.0
31										31.0	32.7
30									30.0	31.7	33.3
29								29.0	30.6	32.3	34.0
28							28.0	29.6	31.2	32.9	34.6
27						27.0	28.6	30.2	31.8	33.5	35.2
26					26.0	27.6	29.2	30.8	32.4	34.0	35.7
25				25.0	26.5	28.1	29.7	31.3	32.9	34.6	36.3
24			24.0	25.5	27.1	28.6	30.2	31.8	33.5	35.1	36.8
23		23.0	24.5	26.0	27.6	29.1	30.7	32.3	34.0	35.6	37.3
22	22.0	23.5	25.0	26.5	28.1	29.6	31.2	32.8	34.5	36.1	37.8
21	22.5	24.0	25.5	27.0	28.5	30.1	31.7	33.3	34.9	36.6	38.2
20	22.9	24.4	25.9	27.4	29.0	30.6	32.1	33.7	35.4	37.0	38.7
19	23.4	24.9	26.4	27.9	29.4	31.0	32.6	34.2	35.8	37.5	39.1
18	23.8	25.3	26.8	28.3	29.8	31.4	33.0	34.6	36.2	37.9	39.5
17	24.2	25.7	27.2	28.7	30.2	31.8	33.4	35.0	36.6	38.3	39.9
16	24.6	26.1	27.6	29.1	30.6	32.2	33.8	35.4	37.0	38.7	40.3
15	25.0	26.4	27.9	29.5	31.0	32.6	34.2	35.8	37.4	39.0	40.7

**\*Select a wet-bulb temperature that is at or above the critical damage temperature for your crop and locate the appropriate column. Then choose the row with the correct dew-point temperature and read the corresponding air temperature from the table to turn your sprinklers on or off. This table assumes a barometric pressure of 1013 millibars (101.3 kPa).**

**Table 5. Dew-Point Temperatures (<sup>o</sup>F) for a Range of Air Temperature and Relative Humidity\*.**

Relative humidity	Temperature ( <sup>o</sup> F)					
	32	36	40	44	48	52
100	32	36	40	44	48	52
90	29	33	37	41	45	49
80	27	30	34	38	42	46
70	23	27	31	35	39	43
60	20	23	27	31	35	39
50	16	19	23	27	30	34
40	10	14	18	21	25	28
30	4	8	11	15	18	22
20	-4	-1	2	6	9	12
10	-18	-15	-12	-9	-6	-3

**\*Select a relative humidity in the left column and an air temperature from the top row. Then find the corresponding dew point in the table.**

**Table 6. Application Rates for Overhead Sprinklers for Frost Protection of Grapevines**

<b>Temperature</b>	<b>Wind Speed</b>	<b>30 second rotation</b>	<b>60 second rotation</b>	<b>30 second rotation</b>	<b>60 second rotation</b>
°F	Mph	in/hr	in/hr	gpm/acre	gpm/acre
29	0.0-1.1	0.08	0.10	36	45
26	0.0-1.1	0.11	0.13	50	59
23	0.0-1.1	0.15	0.17	68	77
29	2.0-3.0	0.10	0.12	45	54
26	2.0-3.0	0.13	0.15	59	68
23	2.0-3.0	0.18	0.20	81	90

Tables 4, 5, and 6 from: Snyder, Richard and J. Paulo de Melo-Abreu. 2005. Frost Protection: fundamentals, practice and economics. Food and Agriculture Organization of the United Nations Rome; Snyder, Richard L. 2001. Principles of Frost Protection FP005 Quick Answer. University of California, Davis; Snyder, R. L., 2000. Sprinkler Application Rates for Freeze Protection FP004 Quick Answer. Department of Land, Air and Water Resources, University of California, Davis.

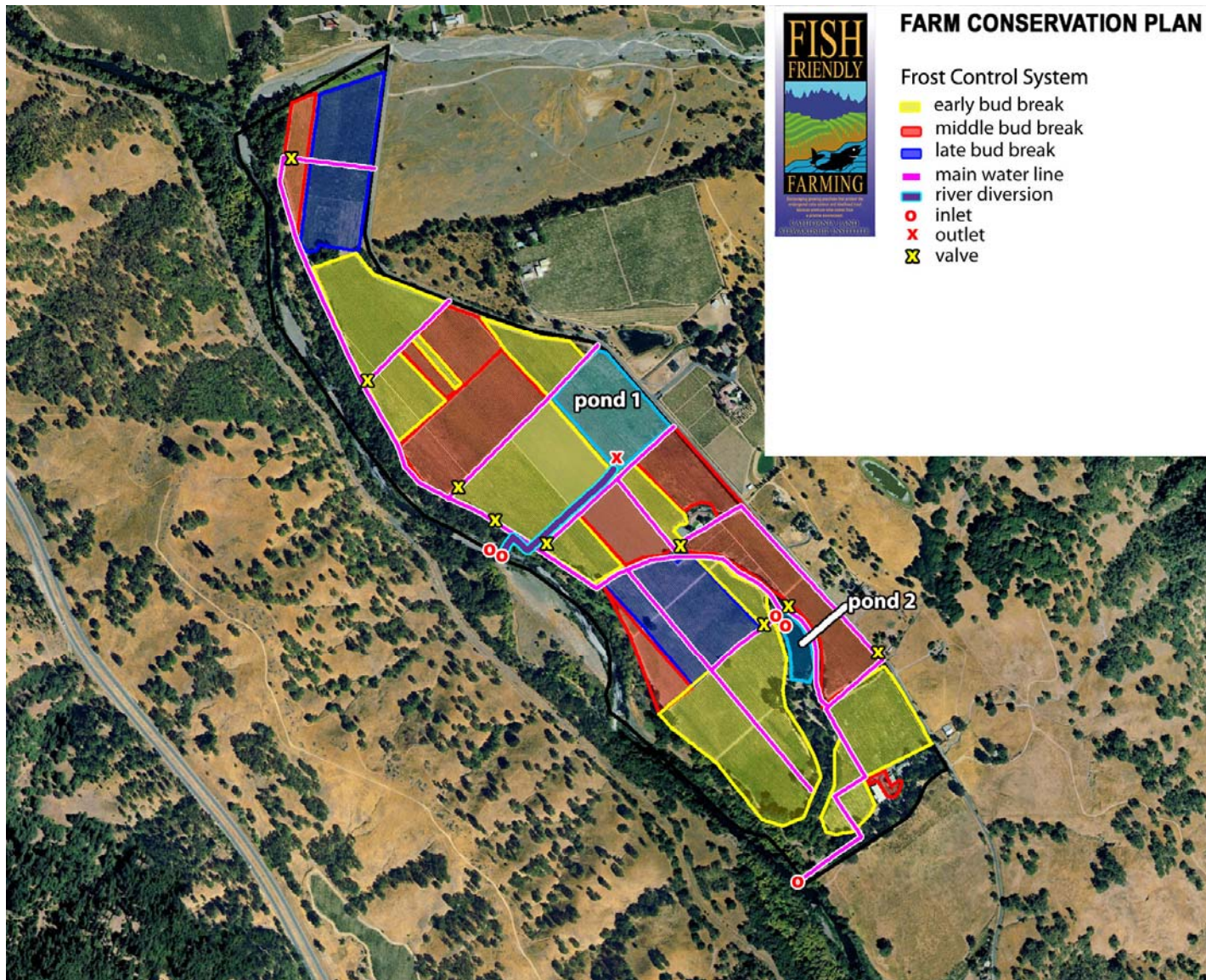

Figure 13. Example of Fish Friendly Farming Farm Plan Map with Frost Control System Outlined



As part of each Fish Friendly Farming Conservation Plan, the water demand for frost control is calculated with and without Best Management Practices (BMPs). Tables 1-5 in Appendix 1 show the components of the calculator analysis. Severe frost zones get too cold for wind machines to be a viable alternative. In severe frost zones, several BMPs conserve the largest amount of water – site specific temperature monitoring to more precisely time the onset of sprinkler use; changing from standard set sprinklers to low flow sprinklers, and installing valves in the water system to apply water only to vineyard blocks which have budded out (Figure 13). Many growers have already changed their systems to incorporate these BMPs.

Replacing water systems with wind machines can be implemented in mild and some moderate frost zone sites. Low spots in hilly areas such as the Carneros area can use 1-2 wind machines and forego the use of water.

### **AGRICULTURAL WATER SYSTEMS**

The agricultural water systems in the Napa River Watershed are private and consist primarily of small systems on each individual property. There is no centralized source of water built by the State or Federal government and distributed by an irrigation district. Instead, each landowner has to develop a water source and system to supply their vineyard. In the frost prone valley bottom areas, water source for frost control may be needed in addition to irrigation. Based upon both the availability of water and size of the vineyard, a property may have several sources of water. The most common types of water supply facilities and their potential for effects on stream flow are described below.

**Groundwater Wells** - In the Napa River Watershed, groundwater is primarily found in the alluvium of the valley and in the Sonoma Volcanics Formation (Kunkel and Upton 1960). When a well pump is running, it creates a cone of depression around it. The cone will vary in size with the power level of the pump and the permissivity of the material around the well. If the cone of depression is near a stream, the stream flow may be drawn into the well and surface flow can rapidly diminish. Streams in alluvium are most subject to effects from adjacent shallow wells (<30 ft.).

Deeper wells or those located away from streams have less potential to affect stream flow. Most wells (>30 ft.) have screens or perforations at different depths and the pump can be set at different depths. These variations can allow for water to be drawn from lower depths which are less likely to have an instantaneous effect on surface flow.

In general, in an alluvial valley, the cumulative effect of water extraction can reduce the groundwater level in the overall well field if more water is removed than infiltrates. In the Napa Valley, monitoring wells are measured by the Department of Water Resources in spring and fall. These measurements show lower groundwater levels during drought years, but no long term trend of decreased groundwater levels over time (West Yost and Associates, 2005). This indicates that groundwater is replenished through infiltration in years with normal or greater rainfall.

**On-stream Reservoirs** – There are numerous small on-stream reservoirs in the Napa River watershed used for agriculture (Figure 14). All of the large reservoirs (>1,000 ac. ft.) are municipal water supply only. On-stream reservoirs impound water by damming small creeks and filling as stream flow increases with winter runoff. The reservoir may have an outlet controlled by a gate or valve as well as a spillway. Stream flow immediately downstream may remain low in the very early

part of the rainy season until the reservoir fills and spills. However, the effect of small reservoirs on delaying the onset of stream flow may be offset by the effect of the large reservoirs on delaying flows in the mainstem river. In alluvial valleys, the groundwater levels in the beginning of the rainy season are low and runoff has to infiltrate and raise the groundwater level before there will be stream flow in the river. In the Napa Valley, the river channel has entrenched 12-15 feet into the alluvial valley floor. The entrenched channel is the lowest point in the valley. The combination of large municipal reservoirs filling until spilling and lower groundwater levels could create delays in the timing and magnitude of flow in the Napa River, limiting fish migration in the overall stream system. The small reservoirs are likely to fill and spill sooner than the large reservoirs and have less of an effect on the overall system.

**Off-stream Reservoirs** - Off-stream reservoirs are berm-enclosed and square or rectangular and are scattered over the valley floor and terrace areas. An off-stream reservoir can be filled through a diversion from a creek or the river; through shallow subsurface pipe networks and a sump; through wells; or with winery or municipal recycled water. Typically, off-stream reservoirs used for frost control are sized to hold water adequate for four nights of frost control. Wells, especially slow producing wells, can be used to fill an off-stream reservoir, creating an adequate volume of water for frost control, but requiring frequent refilling from the well.

**Direct Diversion** - A direct diversion moves water either to an off-stream reservoir or directly into the frost system. The volume of water diverted may be defined in an appropriate permitted/licensed water right or may rely on riparian rights. The greatest effect on stream flow can be caused by numerous direct diversions being turned on at once as in frost control. If water is diverted to a reservoir and then the reservoir water is used for frost control, the volume diverted from the stream can be lower and completed during day time hours when demand is lower.

Along the Napa River there is a state watermaster during the spring frost season. All diverters have to call into the watermaster to find out when they can divert or fill their reservoir. This system was instituted after a lawsuit due to a lack of available water on the downstream reach of the river caused by diversions upstream (Ca. Department of Water Resources 2008).

**Subsurface Collection System** - When a vineyard is developed, perforated pipe set in gravel can be installed to intercept groundwater and direct it to a sump, or cistern. Sumps are typically a vertical culvert 48-72 inches in diameter where the water is collected and held. The water is then pumped either into an off-stream reservoir, or if not needed, into a ditch, creek or other waterway.

**Recycled Water** - Many vineyards are near wineries and may use the treated process water from the winery. Some areas in Napa use municipal recycled water primarily for irrigation, but this source could also be used for frost control. There are restrictions about using winery or recycled water when the vine has grapes but this does not limit use for frost control.

**Effects on Stream Flow** - The diversion and storage of water for frost control can affect stream flow. However there are many different types of agricultural water supply systems and there are many other types of water use including very large municipal reservoirs in the watershed. Diversions for frost control can be managed to reduce stream flow effects if the timing of the diversions are considered and storage is adequate. No general conclusions about the effects of agricultural diversions in the Napa River system can be made without greater levels of monitoring and

evaluation. The Napa River Watershed is similar to the Russian River system where there are large public water supply reservoirs and numerous small agricultural systems in an alluvial valley setting.

### **Measures to Reduce Effects on Stream Flow of Water Diversions for Frost Control**

There are management measures for each type of agricultural water supply facility which can reduce effects on stream flow.

**Deep and Shallow Wells** - Use of groundwater is a common form of water supply for both agricultural and residential uses. Each well draws water from the groundwater basin around it. Determining the precise effect of a shallow well on stream flow can be complex and difficult if the well is in an alluvial valley and not near a stream channel. The effects on stream flow of pumping groundwater from deep wells can also be difficult to determine. Only shallow wells which are immediately adjacent to a stream channel may show an obvious effect on stream flow. Further complicating evaluations of the effects of individual wells on stream flow is that the number of wells operating simultaneously in an alluvial basin may have a larger effect than staggered use of individual wells. Determining the effect of an individual well separate from other wells may be impossible.

Given this level of uncertainty, it may be more valuable to change wells near streams rather than attempt to prove a lack of effects. There are ways to change the depth at which water is drawn and thereby reduce the potential for effects on stream flow. This is done by changing the casing or liner on the well to block the screens or perforations in the top 30-50 ft. of the well (Figure 15). By moving the location of where water is withdrawn to a deeper area, the instantaneous effect on the stream can be reduced. Reducing the size of the pump and withdrawing water at a slower rate (lower well production) can also reduce the instantaneous effects on stream flow.

**On-stream Reservoirs** - Individual on-stream reservoirs can be evaluated for their effects on downstream flow. A flow gage can be established in the tributary creek just downstream of the reservoir location; one to several additional gages can be installed further downstream in the alluvial reach of the creek where it meets the Napa River. The gages can be used to determine whether the on-stream reservoir fills and spills before or after the alluvial reach has continuous flow and what rainfall amounts affect the onset of continuous flow. This type of monitoring will determine when stream habitats have continuous flow and are available to salmonids and whether the on-stream reservoir has a major effect on the timing of continuous flow conditions downstream. If the reservoir typically fills and spills before continuous flow conditions are reached, other limiting factors have a greater influence than the reservoir. In tributaries with large numbers of on-stream reservoirs, the cumulative effect of the fill and spill operations on both the timing and magnitude (stage) of stream flow also needs to be evaluated.

If the monitoring shows the reservoir does affect the timing of continuous flow, it can be retrofitted with a bypass pipe or channel. Then the reservoir can be operated to release the water that flows into it in the early part of the rainy season. Then later into the rainy season, the bypass can be closed and the reservoir allowed to fill and spill. The monitoring can be used to determine the level of rainfall needed before the reservoir bypass can be closed and the reservoir can be allowed to fill.



On-stream Reservoirs



Off Stream Reservoir



Direct Diversion

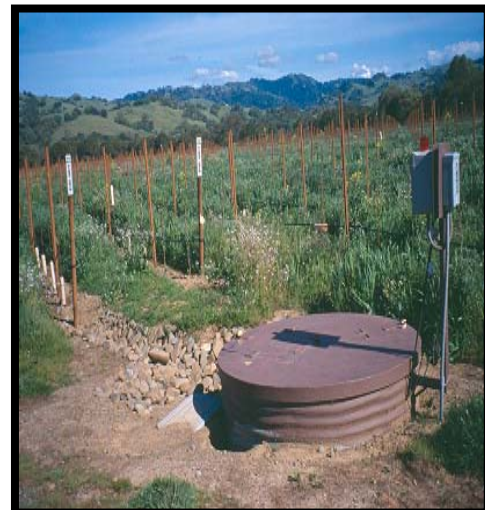

Sump and Subsurface Collection System in Vineyard

**Figure 14. Types of Water Supply Facilities**

**Off-stream Reservoirs**- Off-stream reservoirs should be located out of the floodway of the river and creeks to avoid changing the direction of flood water. There are several different water sources which could be used to fill and off-stream reservoir including:

**Direct diversions** used to fill off-stream ponds can be operated to take a low amount of flow during daylight hours when no large volume diversions for frost control are occurring. The timing and magnitude of the direct diversion should also be limited by the stream flow level at the diversion site and not lower the stage significantly. A stream flow gage at the diversion site can be used to fine tune the timing and volume of diversions to avoid lowering the stream flow by more than 10-20% or below a predetermined stage relevant to fish habitats.

On tributary streams with numerous direct diversions the timing and volume of the diversions may need to be coordinated to avoid significant effects on flows. An inventory of water supply facilities, diversion sites and rates is needed along with installation of stream flow gages and piezometers to calculate a diversion schedule. Additional off-stream storage may be needed to reduce diversion effects.

If a **well** has a low production rate, an off-stream storage reservoir can provide the volume of water needed for frost control.

The operation of **subsurface collection systems** may affect the timing and magnitude of stream flow in nearby creeks in very dry years. Operations can be changed to bypass flow collected in sumps until after several major storms have passed and nearby creeks have continuous flow. For systems of this type located on the valley floor, they are unlikely to affect groundwater levels or stream flow in the Napa River as the majority of recharge to the valley groundwater basin comes from runoff from the adjoining mountains.

### **Direct Diversions**

For those sites where direct diversions provide water directly into the frost system, there are few measures that can be implemented to reduce diversion volumes. The best option is to construct off-stream storage or wells to increase flexibility in managing the timing and volume of the diversion.

### **Recycled Water**

Use of municipal recycled water for frost control represents a water source which does not impact levels of stream flow. However, a vineyard may need to have a perimeter recollection ditch and adjustments to the sprinkler system to avoid movement of the recycled water off the site.

## **TECHNICAL ISSUES AFFECTING IMPLEMENTATION OF ALTERNATIVE FROST CONTROL METHODS**

Technical issues affecting a grower's ability to reduce water use in frost control and increase instream flows fall into several categories:

- Physical features and location of the vineyard site and limitations of alternative frost technology.
- Physical processes of stream flow, effects of frost water diversions and other alterations in the basin.

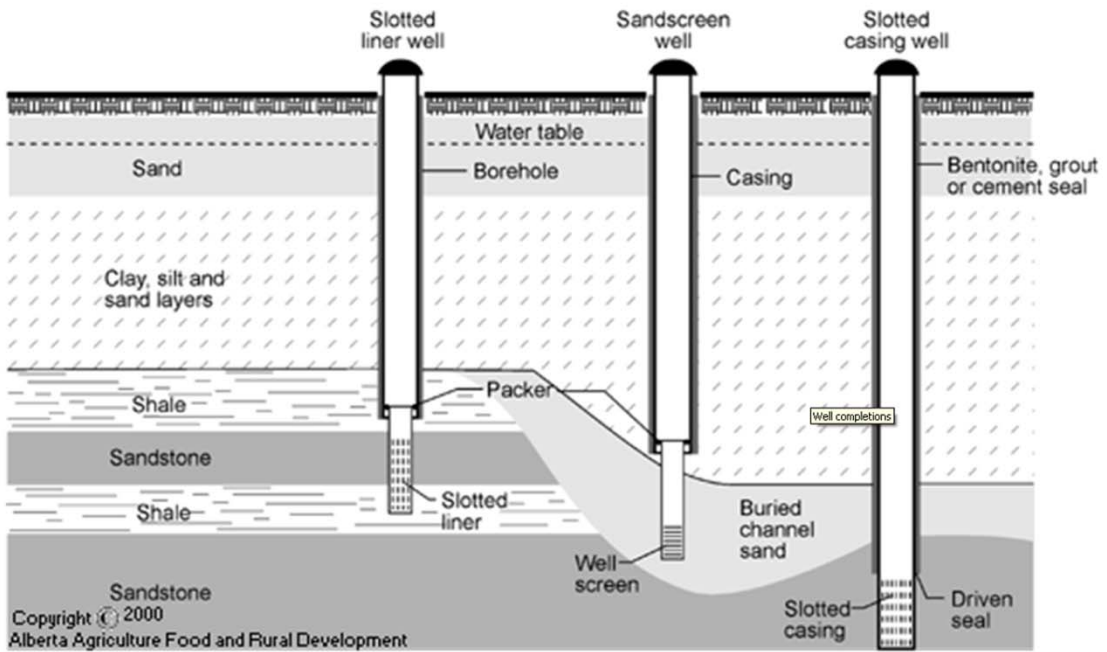
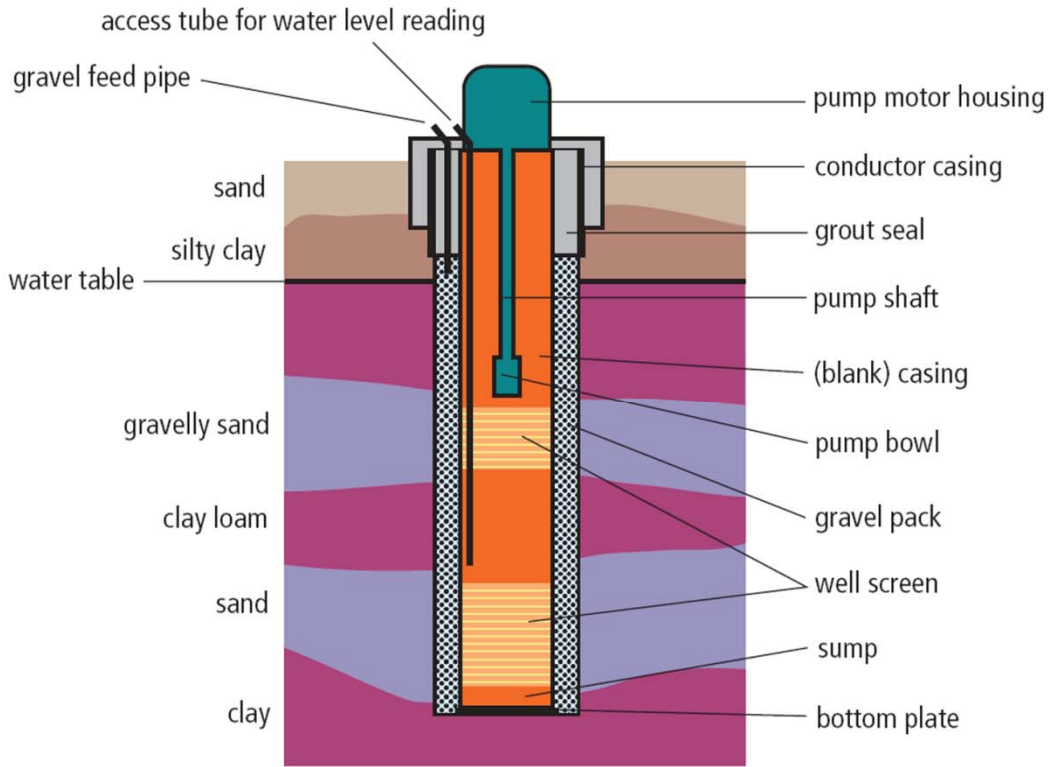

Figure 15. Drawings of wells illustrating the varied locations of well screens and seal/casing.

### **Physical Features and Location of Vineyard Site and Limitations of Alternative Frost Technology**

The physical features and location of a vineyard site determine the type of frost temperatures that will occur and whether a change in frost control practices within the vineyard can be achieved. Basically, for sites in severe frost zones where spring temperatures drop to 27°F or below, water and standard set sprinklers are the only effective frost control measure. For these sites, there are water demand management measures or BMPs that can be implemented such as mowing cover crops, installing valves in the water system to limit water application by vineyard blocks and variety, and precise temperature monitoring to delay sprinkler turn on. Use of these BMPs will reduce the volume of water used but a substantial volume of water will still be needed.

Low flow and microsprinkler technology has not proven effective in severe frost zones and needs to be improved if these products are to be used in these areas.

For moderate and mild frost zones, there are more management measures which can reduce the volume of water used. Wind machines can provide frost protection down to 29°F and can replace the use of water in many sites in mild and moderate zones. Low flow and microsprinklers are an effective technology in mild and moderate frost zones.

In summary, water demand measures are adequate to reduce or replace water use in mild and moderate frost zones but are not adequate for severe frost zones. For severe frost zones, revising water source facility management is needed to reduce effects of water diversion for frost control on stream flow.

The technical limitations to water source facility changes are primarily dictated by site-specific features. Designing adequate size storage on steep sites without damming streams is difficult. Retrofitting on-stream dams to have a bypass facility is also challenging and may require rebuilding the dam or spillway structure. Revising groundwater wells to draw water from deeper levels requires installing a sleeve into the casing or lining the well. Many wells cannot undergo this change and there is no other method to block or seal the upper 30-50 feet of the casing. The available technology is not adequate for changing all wells. As discussed later in this report, the institutional barriers to changing water sources are even greater.

### **Physical Processes of Stream Flow, Effects of Frost Water Diversions and Other Alterations in the Basin**

The goal of revising frost control practices is to retain more flow in tributary creeks and the Napa River. However it is incorrect to presume that if water was not used for frost control, then the tributary creeks would have continuous flow all winter and spring.

The Napa River Watershed has numerous other reservoirs, diversions and physical changes that alter the timing and magnitude of stream flow. The most defining feature of the Napa River Watershed is its alluvial valley and the groundwater basin it creates. In this type of watershed, runoff from the mountains infiltrates into the valley basin until the groundwater level rises and intersects with the river channel and tributary creeks and surface stream flow occurs. Even if stream flow is constant in the mountains, flow over alluvial fans may be intermittent. If flow in the Napa River is low due to the filling of the large reservoirs, the alluvial reach of a creek may not have

connected flow. In dry years or years with long rainless periods, alluvial creek reaches may go dry several times in winter/spring.

To characterize current stream flow processes in the Napa River watershed and isolate the effects of frost control diversions, extensive stream flow monitoring and groundwater level monitoring has to be done. This characterization is needed as a baseline for comparison with future conditions. Additionally, each tributary will have different conditions due to the number and type of large or small reservoirs, diversions and shallow wells. It will be a technical challenge to develop monitoring programs with the level of accuracy and precision needed to demonstrate the effectiveness of water demand management measures to reduce the effects of diversions for frost control. Landowners and vineyard managers will need to be intimately familiar with stream flow and groundwater maintaining in order to revise their diversions and create a coordinated program with other growers for the purposes of monitoring stream flow.

It is important to have synoptic sampling at numerous locations in the watershed due to the interaction of surface and groundwater in the basin. It is most efficient to have landowners/managers carrying out the monitoring so that numerous sites can be sampled at the same time. Growers can be properly trained in the methods of establishing stream flow and groundwater level gages at numerous locations. Each grower will need to demonstrate QA/QC measures used. However, the data developed will need to be interpreted by hydrologists and geomorphologists and possibly augmented with topographic surveys in some locations. Our report under Tasks 3 and 4 will further discuss this concept.

### **INSTITUTIONAL ISSUES AFFECTING IMPLEMENTATION OF ALTERNATIVE FROST CONTROL METHODS**

Within a property or farm, it is relatively easy to change certain features of the frost control system. Installing additional weather stations or valves in vineyard blocks requires some additional capital expenditure but no permits. The water conservation calculator (Appendix 1) lists the costs of the various BMPs and allows a grower to review the cost/ac. ft. of water savings to determine the most effective scenario for a particular site. Revising the water facility or changing the water source can be both expensive to the grower and require a decade or more for permit approval.

Institutional issues affecting a grower's ability to implement alternative frost control measures include:

- Local government permitting requirements and restrictions for building various water supply facilities
- State water rights permitting system and instream flow policies
- Infrastructure and potential regulatory constraints on the use of recycled water

#### **Local Requirements**

Certain revisions to water supply facilities require local government approval by Napa County. The building of an off-stream pond requires a county grading permit. An engineered plan with a soils and geology report and CEQA review is required for the grading permit. Additional studies may be needed for the CEQA review such as archaeological site review and rare plant surveys. In addition, a Floodplain Management Permit may be needed. Under the requirements for this permit, building a



pond on the valley floor cannot impact riparian habitat, creek and river channels. The location of each pond has to be reviewed for effects on the direction or depth of flood water. In most locations, the off-stream pond will have to be developed from vineyard or fallow agricultural land, not wildland. Under both Federal and County regulations a new pond cannot increase flood hazards.

Drilling wells for agricultural water supply is regulated in one area of the valley – the Milliken-Sarco-Tulocay (MST) area (Figure 16). This groundwater basin has been declared deficient by Napa County due to declining groundwater levels. Between 2002-2009, static groundwater levels declined between 0 and 120 ft. (Napa County 2005). This groundwater basin is partially alluvium but primarily Sonoma Volcanic Formation. It is not part of the large Napa Valley alluvial groundwater basin.

In this area, vineyard use of groundwater is limited to 0.3 ac. ft./acre/year. This restriction is implemented through a requirement for a groundwater permit as part of a County erosion control plan for replanting an existing vineyard or developing a new vineyard. The grower is also required to meter their well and report water use to the Napa County Department of Public Works.

No other groundwater basin in Napa has declining groundwater levels and is regulated by Napa County. Surface water sources are not regulated by Napa County in the MST area.

There are planning efforts under way to develop the infrastructure to bring municipal recycled water from Napa Sanitation District for use in the MST area to reduce dependence on groundwater.

### **State Requirements**

The State of California regulates the diversion and use of surface water through the reasonable and beneficial use doctrine of Article X, Section 2 of the California Constitution, the public trust doctrine, Porter-Cologne Water Quality Control Act, water right permitting requirements, and other authorities that are enforced primarily by the State Water Resources Control Board (SWRCB). The SWRCB does not regulate groundwater in most areas.

### **Types of Water Rights**

California has a dual system of water rights which incorporates the riparian doctrine from English common law and the appropriative doctrine.

**Riparian water rights** are derived from owning land adjacent to a lake, creek or river and do not require a permit from the SWRCB. Riparian rights are not quantified; a riparian user is entitled to divert a reasonable quantity of the “natural” flow of the water source for beneficial purposes on the riparian land. In general, riparian water rights are senior to appropriative water rights for the same water body; water may be diverted for appropriative rights only after riparian uses have been satisfied. Riparian rights have the same priority and are “correlative” such that in times of water shortage all riparian uses must be reduced. Riparian rights are not lost due to a lack of use. Riparian water can be “regulated” in a reservoir, pond or tank for a short period of time (generally assumed to be 30 days or less) but cannot be “stored”. Starting in 2010, riparian water users are required to file a Statement of Water Diversion and Use to the SWRCB every three years.

**Appropriative water rights** are gained by the diversion and application of water to beneficial use and are not derived from ownership of land adjacent to a surface water body like riparian rights.

Appropriate rights can be lost if non-use occurs for 5 years or more. Appropriative water rights are given priority by the date of their issuance.

Prior to 1914 and the passage of the State Water Code, appropriative water rights were claimed, posted and recorded in county records. Pre-1914 water rights are water rights claimed through this earlier process. Starting in 2010, pre-1914 appropriate water right holders are required to report water use to the SWRCB every three years.

After 1914, water may be appropriated only pursuant to a permit issued by the SWRCB. Appropriative water right permits can authorize direct diversion (which includes regulation of water for 30 days or less) or storage (greater than 30 days) of a defined volume of water. Permits specify the precise location where water may be diverted (point of diversion or POD), the specific uses of the water (e.g., irrigation, domestic, etc.) and the location where the water may be used, the diversion period (season), and the rate and volume of water diversion. Once a permit has been issued, the diversion and/or storage facility has been built and the water has been put to the intended beneficial use, a water right license can be issued. Water right permittees report their water use to the SWRCB in annual progress reports. Licensees report in biennial reports.

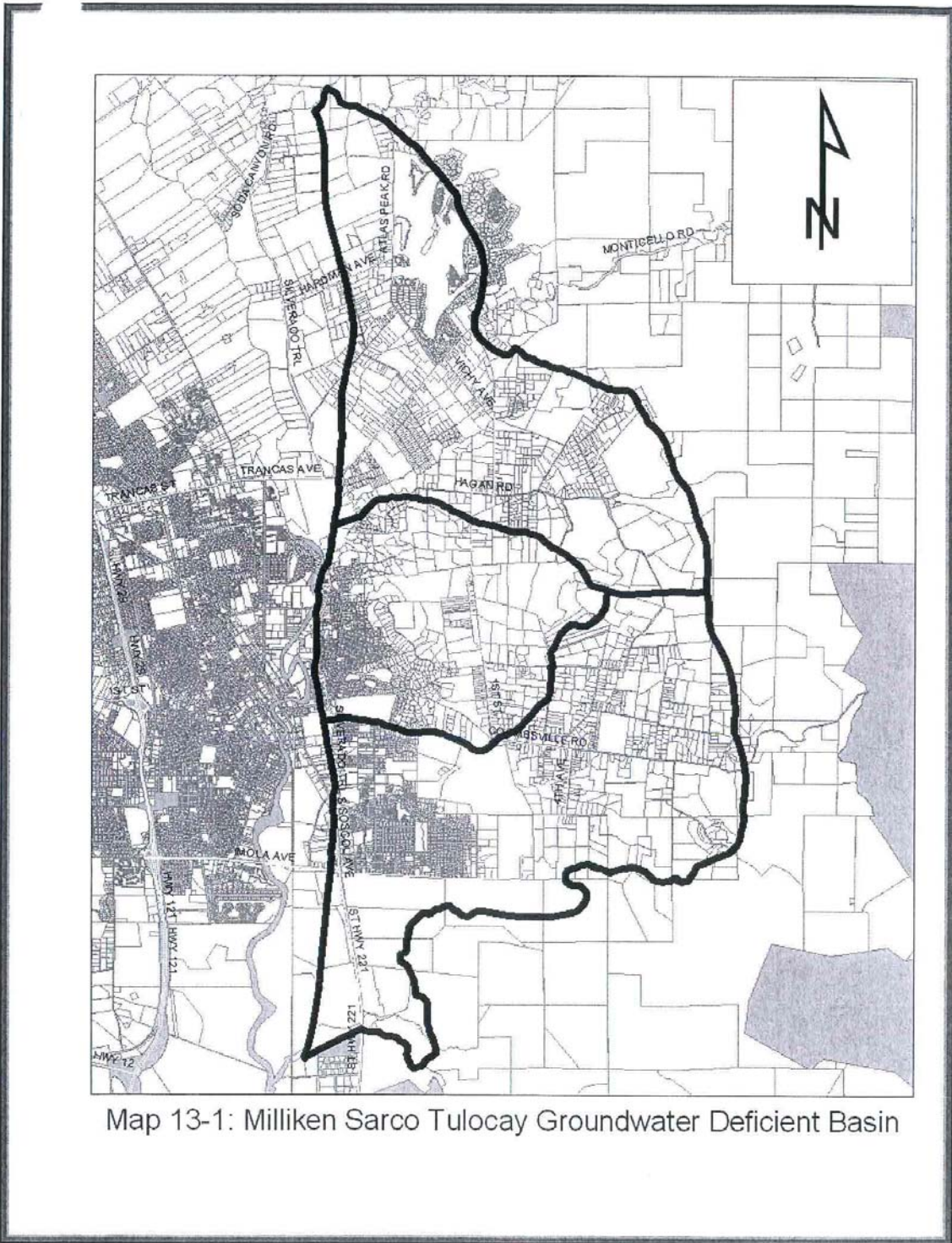

Figure 16. Milliken Sarco Tulocay (MST) Groundwater Area

The water right permitting process has become complex, time consuming and costly for applicants. According to the SWCRB Diversion of Water Rights website, the steps in applying for an appropriative water right permit include:

- *Filing an Application. The process is initiated when a permit application is filed by the person or agency desiring to divert water. This application specifically describes the proposed project's source, place of use, purpose, point(s) of diversion and quantity to be diverted.*
- *Acceptance of Application. The Board notifies the applicant within 30 days whether the application is incomplete or accepted. Acceptance establishes priority as the date of filing.*
- *Public Notice. The State Board then publishes a notice of the applicant's intent and invites comment. Copies of any protests are given to the applicant who is required to respond.*
- *Environmental Review. Consideration of environmental effects is required by the California Environmental Quality Act before a permit can be issued. Large projects that could endanger or degrade natural habitat or water quality usually require preparation of an Environmental Impact Report. The Board examines the proposed project's potential environmental impacts and determines whether conservation measures will be needed.*
- *Protest Resolution. The State Board takes actions to resolve any protests that have been filed. If both parties can agree to mutually acceptable conditions, the protest is resolved at this point in the process. In the event it is not resolved for small projects, the issue may be solved through an engineering field investigation report from the Board's Division of Water Rights. For appeals from the report and or large projects, a formal hearing is held before one or more members of the State Board. The Board's decision is based upon the record produced by the hearing.*
- *Permit Issuance. Two initial Board findings are required before a permit can be issued: that unappropriated water is available to supply the applicant, and that the applicant's appropriation is in the public interest, a concept that is an overriding concern in all Board decisions. The permit is then issued if the Board determines that the proposed use of water best meets these criteria. If it determines otherwise, conditions may be imposed to ensure they are satisfied or the application may be denied. In most cases, the applicant is required to begin project construction within two years of permit issuance.*

## **Napa River Watershed Water Rights**

According to the SWRCB Division of Water Rights database, Napa River Watershed has approximately 527 pending, permitted and licensed appropriative water rights (Table 7). These include six large municipal reservoirs and numerous small agricultural reservoirs and a total "face value"<sup>1</sup> 81,450 ac. ft. of water. Figure 17 depicts these appropriative water rights by subwatershed in the Napa River basin. These rights which include storage are marked with an "S". Of the 527 appropriative water rights, only 23 are pending applications.

## **Napa River Watermaster Program**

Water diversions from the Napa River for frost control are controlled through the watermaster program of the Department of Water Resources. The SWRCB in 1972 adopted a regulation declaring

---

<sup>1</sup> The face value of a water right is the maximum quantity authorized for diversion under a permit or license. The face value is often much greater than actual water use, and accordingly, the face value total overstates actual water use in the Napa River Watershed.

that all significant direct diversions of water from the Napa River stream system between March 15 and May 15 are “unreasonable” and a violation of Water Code Section 100 except for diversions to replenish storage that are controlled by a watermaster administering a board or court approved distribution program. In 1974, the SWRCB sued riparian water users who refused to discontinue direct diversions during the frost season. The riparian users asserted that direct diversion was a reasonable exercise of riparian rights over which the State had no jurisdiction. This regulation and the Trial Distribution watermaster program were upheld by a court judgment in 1976 called the Forni Decision. The watermaster directs the timing of diversions from the Napa River for frost control. Each diversion is required to have a meter and growers must provide access and information to the watermaster. The growers directly divert or fill their off-stream reservoirs as directed by the watermaster. In low water years, water is allocated to the riparian right holders according to acres of vineyard. Appropriative right holders are allocated water only once the riparian right holders’ needs are met. The cost of the watermaster is billed to all of the participants (Ca. Department of Water Resources 2008).

### **North Coast Instream Flow Policy**

In May 2010, the SWRCB adopted a policy to govern new and pending appropriative water right permits and certain changes to permitted and licensed water rights (SWRCB 2010). This policy was formulated in response to Assembly Bill 2121 passed in 2004. The policy outlines methods for analyzing the effects of pending and new appropriative water right applications on anadromous salmonids in 3.1 million acres of coastal streams in portions of five counties including the Napa River Watershed.

This policy contains a new methodology for evaluating water flows and a very strict set of environmental requirements for pending and new appropriative water right applications and petitions. Most of the appropriative water rights in the Napa River Watershed (Table 7) are permitted or licensed and this policy would not directly affect them. However, if a grower wants to change his or her water source, method of diversion, place of use, operation of the diversion facility, point of diversion or obtain an extension of time of a permit to construct facilities or use more water, this new policy applies to the application, or petition, for the revision of the water right even if the only reason for the revision is environmental improvement.

The policy adopts five new principles or restrictions on new permits and amended permits and licenses:

- 1. Water diversions shall be seasonally limited to periods in which instream flows are naturally high to prevent adverse effects to fish and fish habitat (Dec 15-March 31);*
- 2. Water shall be diverted only when stream flows are higher than the minimum instream flows needed for fish spawning, rearing, and passage;*
- 3. The maximum rate at which water is diverted in a watershed shall not adversely affect the natural flow variability needed for maintaining adequate channel structure and habitat for fish;*
- 4. The cumulative effects of water diversions on instream flows needed for the protection of fish and their habitat shall be considered and minimized; and*

5. *Construction or permitting of new onstream dams shall be restricted. When allowed, onstream dams shall be constructed and permitted in a manner that does not adversely affect fish and their habitat.*

The policy principles are primarily designed to protect salmonid fishes and the policy requirements apply to every stream within the Napa River Watershed including streams that do not support salmonids.

The policy principles are implemented through regional criteria, which are a suite of general requirements including numeric bypass flow requirements derived from conservative equations, or site specific criteria tailored to the specific project that are developed through site specific studies.

Applicants are required to prepare all of the studies needed to evaluate the effects of the diversion and how it meets the policy requirements. The majority of Napa's appropriative water rights for both agricultural and municipal use were issued prior to modern environmental review laws. The policy studies include: Water Availability Analysis with a Water Supply Report, Upper Limit of Anadromy Determination, Cumulative Diversion Analysis, and Site Specific Studies to identify instream flow needs at locations at or below anadromy. Each of these studies and reports has detailed requirements.

The Water Supply Report has to include:

1. *A map showing the locations of the points of diversion (PODs) of senior priority water right holders and water right claimants in the watershed.*
2. *A list of all senior priority water rights (permit, license, certificate, or registration), their seasons of diversion, and face values of their permits or licenses. To the extent information is available in the State Water Board's records, or other sources of information, the demand and season of diversion of riparian and pre- 1914 appropriative water right holders and claimants should also be included;*
3. *Unimpaired flows may be estimated either through an adjustment of stream flow records method or through the use of a precipitation-based stream flow model. If reference stream flow gages are used in the analysis, the water supply report shall include a description of the reasons why the selected stream flow gage is appropriate for use in the analysis.*
4. *A tabulation of the estimated percentages of unappropriated water supply available at the POD for each senior priority water right on the water flow path after accounting for senior demands. This percentage may be obtained using estimates of the unimpaired flow volume of the stream at each senior POD and the seasonal demand volumes of the senior water right holders. The seasonal demand volume is the sum of the demand volumes of the senior water right holders with the right to divert water during the proposed project's diversion season that are within the watershed upstream of identified senior PODs along the water flow path. The demand volume shall be determined using the face value or maximum annual use limitation of each water right; however there may be diversions for which proration of face values or maximum annual use limitations may be appropriate.*

5. *A calculation of the ratio of the proposed project's demand to the remaining unappropriated water supply at each identified senior POD. This analysis is needed for the purposes of (1) identifying locations where the proposed project is likely to have minimal impacts to the rate of flow, and (2) to assist with selection of points of interest for the cumulative diversion analysis. The ratio shall be obtained by dividing the proposed project's water demand volume by the remaining unappropriated water supply at each senior POD.*
6. *A flow frequency analysis of the seasonal unimpaired flow volume. A set of flow frequency analyses shall be provided at the POD(s) of the proposed project, the senior POD at which the percentage calculated in step 3 is the lowest, and any other senior PODs at which the ratio is less than 50%, if any. The frequency of occurrence of the average seasonal unimpaired flow volumes for each year of record should be determined and plotted graphically.*
- 7.

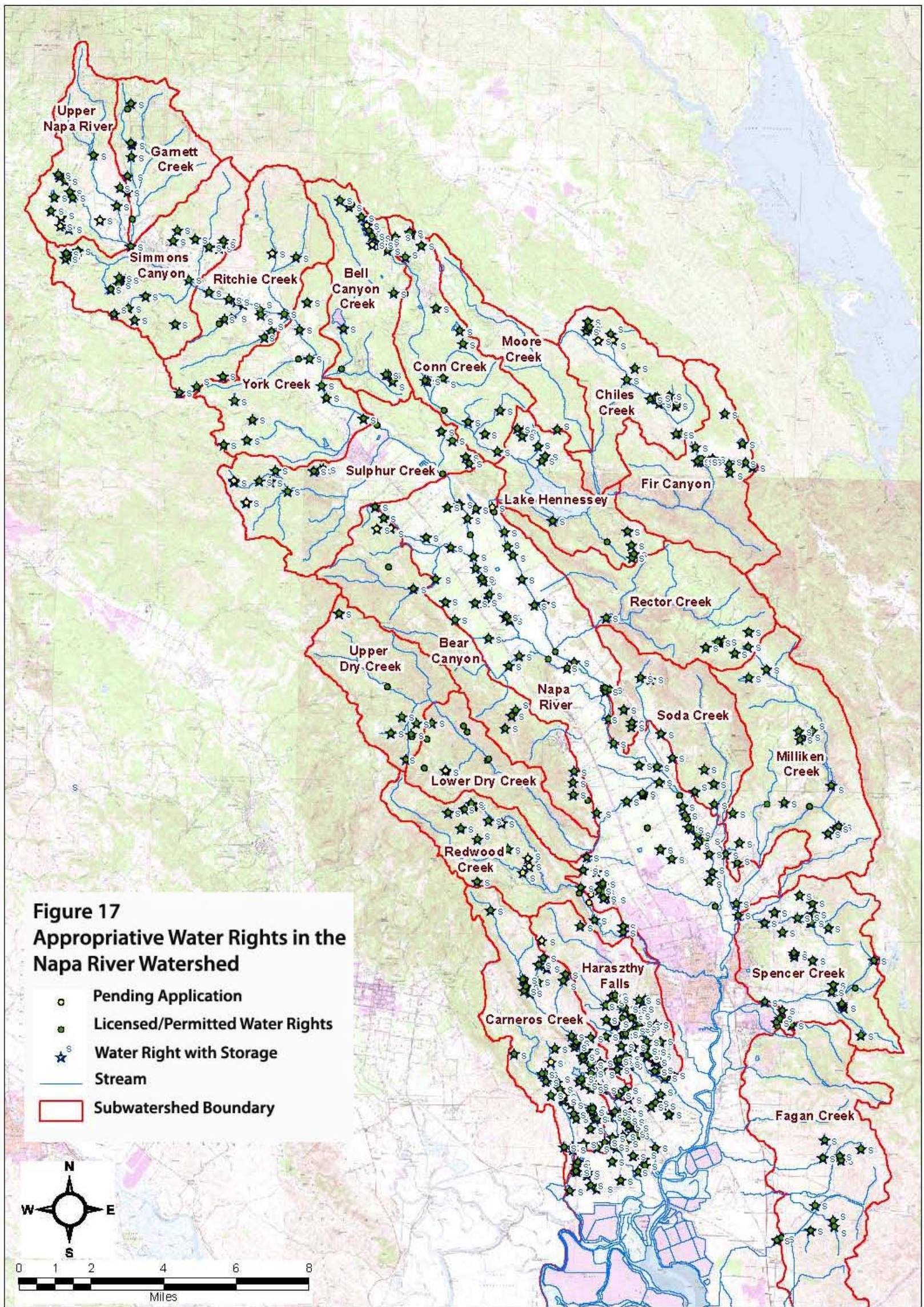



**Table 7. Appropriative Water Rights in the Napa River Watershed for Agricultural and Municipal Uses**

	<b>Subwatershed</b>	<b>Number of Appropriate Water Rights</b>	<b>Face Value of Water Right</b>	<b>Acres of Subwatershed</b>
571	Upper Napa River	14	1851.5	6,177
	Licensed	11	942.8	
	Pending	2	51.7	
	Permitted	1	857	
575	Garnett Creek	7	101.8	5,088
	Licensed	6	73.8	
	Permitted	1	28	
592	Simmons Canyon	19	245.4	8,553
	Licensed	16	175.4	
	Permitted	3	70	
595	Ritchie Creek	16	447.5	8,768
	Licensed	11	275.5	
	Pending	1	15	
	Permitted	4	157	
599	Bell Canyon Reservoir	35	5973.4	6,830
	Licensed	22	827.9	
	Pending	2	205	
	Permitted	11	4940.5	
605	Conn Creek	15	766.1	7,297
	Licensed	9	270.1	
	Permitted	6	496	
607	Moore Creek	1	1.3	4,819
	Licensed	1	1.3	
611	York Creek	15	231.4	8,444
	Licensed	14	182.4	
	Permitted	1	49	
616	Chiles Creek	13	441.5	7,293

**Table 7. Appropriative Water Rights in the Napa River Watershed for Agricultural and Municipal Uses**

	<b>Subwatershed</b>	<b>Number of Appropriate Water Rights</b>	<b>Face Value of Water Right</b>	<b>Acres of Subwatershed</b>
	Licensed	10	322.5	
	Pending	2	98	
	Permitted	1	21	
624	Fir Canyon	14	683	8,195
	Licensed	2	110	
	Permitted	12	573	
627	Heath Canyon	15	521.3	10,141
	Licensed	8	258.3	
	Pending	2	70	
	Permitted	5	193	
632	Lake Hennessey	16	43553.6	5,761
	Licensed	8	140.7	
	Permitted	8	43412.9	
642	Napa River	131	9648.1	82,199
	Licensed	82	3078.5	
	Pending	7	204	
	Permitted	42	6365.6	
643	Rector Reservation	8	4679	9,325
	Licensed	3	3554	
	Permitted	5	1125	
644	Bear Canyon	12	1913.2	9,377
	Licensed	5	54.9	
	Pending	1	52	
	Permitted	6	1806.3	
654	Upper Dry Creek	8	77.6	6,107
	Licensed	7	47.6	
	Permitted	1	30	
656	Milliken Reservoir	22	6098.1	12,439
	Licensed	16	2641.1	

**Table 7. Appropriative Water Rights in the Napa River Watershed for Agricultural and Municipal Uses**

	<b>Subwatershed</b>	<b>Number of Appropriate Water Rights</b>	<b>Face Value of Water Right</b>	<b>Acres of Subwatershed</b>
	Permitted	6	3457	
658	Soda Creek	9	187.8	7,070
	Licensed	7	108.8	
	Permitted	2	79	
665	Lower Dry Creek	7	59	5,679
	Licensed	5	14	
	Pending	1	15	
	Permitted	1	30	
669	Redwood Creek	18	355.7	6,975
	Licensed	9	150.7	
	Pending	3	79	
	Permitted	6	126	
679	Spencer Creek	28	723.7	9,035
	Licensed	25	479.7	
	Permitted	3	244	
680	Carneros Creek	49	2184	9,577
	Licensed	19	657	
	Pending	2	72	
	Permitted	28	1455	
683	Haraszthy Falls	46	1281.2	6,068
	Licensed	24	399	
	Pending	1	9.7	
	Permitted	21	872.5	
691	Fagan Creek	9	295.9	18,698
	Licensed	5	73.9	
	Permitted	4	222	
	<b>Grand Total</b>	<b>527</b>	<b>82321.1</b>	<b>82199.2</b>

The determination of the Upper Limit Anadromy is required regardless of the location of the project. This study has to include:

1. *A study, previously accepted by the State Water Board, National Marine Fisheries Service (NMFS), or (California Department of Fish and Game) DFG, that identifies the location of the upper limit of anadromy on the stream reach between the POD and the Pacific Ocean or to a flow-regulated mainstem river, depending on the water flow path. Previous studies or surveys that catalog only the presence or absence of anadromous fish might not accurately define the upper limit of anadromy.*
  2. *Information demonstrating that the gradient of a segment of the stream reach between the POD and Pacific Ocean or to a flow-regulated mainstem river, depending on the water flow path, exceeds a continuous longitudinal slope over a distance of large enough magnitude that anadromous fish cannot move upstream beyond the lowest point of the gradient. The gradient shall be a continuous longitudinal slope of 12%, or greater, over a distance of 330 feet along the stream.*
  3. *Site-specific studies conducted by a qualified fisheries biologist. The applicant may refer to stream classification determinations for preliminary refinement of the geographic extent of the site-specific study. Prior to conducting the site-specific study, the name(s) and qualifications of the individual(s) selected to perform the studies shall be submitted to the State Water Board for review and approval. All field work, modeling, analysis, and calculations performed as part of this study shall be documented in detail sufficient to withstand credible peer review. The site specific studies shall consist of any of the following:*
    - a. *Identification of an impassable natural waterfall. This policy assumes all natural waterfalls are passable unless the applicant provides information satisfactory to the State Water Board that the waterfall is impassable. This information shall include, at a minimum, an evaluation of waterfall drop height, leaping angle, and pool depth in comparison to the documented ability for the target anadromous fish species to successfully ascend the barrier.*
    - b. *Identification of an impassable human-caused barrier. The applicant may choose to demonstrate that the upper limit of anadromy is located below a human-caused barrier such as a dam, culvert, or bridge. This policy assumes that all human-caused barriers are passable or can be made passable unless the applicant provides information satisfactory to the State Water Board that a man-made barrier is impassable and will never be made passable.*
    - c. *Habitat-based stream survey that delineates the upper limit of anadromy based on quantifiable stream conditions*
1. *The stream survey shall extend an appropriate distance within the stream channel. In general, a minimum distance of 25 bankfull widths upstream and downstream of the POD and a total stream survey length of a minimum of 50 bankfull widths will capture the variability within a given stream.*

2. *Quarterly surveys using appropriate sampling and/or collection equipment shall be conducted to determine the presence of fish, aquatic non-fish vertebrates, and/or aquatic benthic macroinvertebrates. These surveys shall be conducted in the spring, summer, fall, and winter, for at least two years; unless it is demonstrated that the presence of fish, aquatic non-fish vertebrates, and/or aquatic benthic macroinvertebrates can be determined in a shorter time period.*
3. *A survey of instream habitat conditions shall be made at low flows during the diversion season. Examples of instream habitat condition metrics that could be measured include:*
  - a. *Mean residual pool depth*
  - b. *Mean riffle crest depth*
  - c. *Mean riffle width*
  - d. *Mean channel bankfull width*
  - e. *Mean channel longitudinal gradient*
  - f. *Water temperature*
  - g. *Amount and type of cover*
  - h. *Substrate type*

*A visual survey shall be made after a storm runoff event for evidence of sediment transport. Such evidence may include, but is not limited to, the presence of gravel bars and deposits composed of gravel and sand. Annotated photographs must be provided for documentary evidence.*

Projects that cannot (or choose not to) satisfy one or more of the conservative regional criteria must prepare Site Specific Stream Studies to document the features of the stream and develop site specific criteria. Most of the site specific study methodologies identified in the policy apply to alluvial stream channels and some features described in the requirements such as riffle crest and bankfull width are not applicable to entrenched channels, bedrock and boulder or confined channels, alluvial fans and other stream features that are common in the Napa River Watershed.

The fourth requirement is a Cumulative Diversion Analysis. There is an assumption underlying the description of the requirements for this analysis that there are no impairments to stream flow except for other appropriative water rights. None of the existing natural and man-made limitations to connected flow, including alluvial fans, the entrenched river channel and alluvial basin are considered in the analysis.

*The Cumulative Diversion Analysis is required to evaluate whether or not the proposed project, in combination with senior diversions, adversely affects instream flows needed for the protection of fishery resources. In cases where the Cumulative Diversion Analysis demonstrates that the proposed project, in combination with senior diversions, significantly affects instream flows, water may not be available for appropriation.*

*The Cumulative Diversion Analysis requirements vary depending on the proposed project's location in the watershed. The analysis considers senior diversions in the watershed between the proposed project and the most downstream Point of Interest (POI), and contributory flows from tributaries draining into the flow path. Contributory flows from tributaries draining into the flow path can reduce the impacts of diversions in Class III or II watersheds on stream flows needed for fish in Class I streams. At points of diversion located above anadromy, the change in hydrology near the POD may appear significant. However, downstream, at and below the upper limit of anadromy, where salmonids can be affected,*

*the change in hydrology can be slight. Depending on the hydrology and level of impairment in watersheds above anadromy, situations may exist in which diversions could operate with reduced or no minimum bypass flows and/or rates of diversion. The Cumulative Diversion Analysis allows projects upstream of anadromy to determine the minimum bypass flows and rates of diversion needed for their project by evaluating whether the project adversely affects instream flows needed for fishery resources where anadromy exists, after consideration of the flow reductions by senior diverters and contributory flows from stream tributaries. The Cumulative Diversion Analysis Reports shall include the following information:*

- 1. The minimum bypass flow and maximum rate of diversion that were used to achieve compliance with the cumulative diversion analysis requirements;*
- 2. The details of the minimum bypass flow and maximum cumulative diversion calculations for Points of Interest (POIs) located at and below anadromy, if regional criteria were used;*
- 3. Where needed, documentation of the site-specific studies that were performed to identify more precisely the instream flow needs of the fishery resources at the A-17 POIs located at and below anadromy;*
- 4. The details of a daily analysis of the estimated effects of the proposed project and senior diversions on instream flows needed for spawning, rearing, and passage at each POI located at and/or below anadromy, including an evaluation of the number of days that instream flows meet or exceed the minimum bypass flow requirement at each POI located at and/or below anadromy for three flow conditions: unimpaired; impaired without the proposed project; and impaired with the proposed project. The report shall also include the average percent change by month over the period of record between the number of days flow exceeded the minimum bypass flow requirement and/or the February median flow bypass requirement in the unimpaired condition and the impaired condition. The percent change for the impaired condition shall be evaluated for both scenarios, senior diverters only and senior diverters with the proposed project;*
- 5. The details of a daily analysis of the estimated effects of the proposed project and senior diversions on the natural flow variability of the stream at each POI located at and/or below anadromy, which consists of calculating the 1.5-year instantaneous peak flow for three flow conditions: unimpaired, impaired without the proposed project, and impaired with the proposed project, then either comparing these values against the maximum cumulative diversion criteria or comparing impaired conditions with and without the project.*

Once these studies are completed, a CEQA document must be prepared. Many projects will require mitigation including non-native species eradication, gravel and wood augmentation, or riparian habitat replacement. Projects with on-stream dams require a passive bypass system or automated computer-controlled bypass system. A monitoring program is also required.

The cost of preparing these reports and CEQA documents can be in excess of \$300,000, even for a 5-10 ac. ft. pond on a ridgetop well upstream of any salmonid habitat. Besides the reports required by the Instream Policy, the methods allowed for determining bypass flows involve a regional criteria

which is controversial, being formulated from a very small dataset for the very large 3 million acre policy area. Additionally as noted previously, the natural features of river systems like the Napa and Russian Rivers include large alluvial valleys, alluvial fans and man-made alterations in the timing and magnitude of stream flow which the Instream Policy does not address. The required analysis does not take into account losses of stream flow to groundwater as occurs in the large alluvial valleys of the Napa and Russian Rivers. The implementation of bypass flows for a small agricultural water facility are required but are not analyzed in the larger watershed context of the timing of river flows affected by large municipal reservoirs and recharge of the alluvial basin. Many agricultural facilities may not affect connected flow needed for fish migration when compared to existing conditions in the Napa River Watershed.

In addition to the expense of preparing the reports required for a change in a water right there are also long delays. The SWRCB processes very few appropriative water rights permits each year. In 2009, a total of 10 permits were issued out of a backlog of 275 in Napa, Sonoma and Mendocino Counties (SWRCB 2010). There are a number of appropriative water right permits and petitions which were filed 10-20 years ago and have not yet been issued or denied. During that time, the SWRCB has changed its criteria and procedures for issuing water right permits multiple times. These long delays and changing criteria and procedures are significant barriers to changing an existing water right.

The Policy does include provisions to expedite, and in some cases exempt from policy diversion criteria, new water rights and changes to existing water rights that provide environmental improvements:

- *The Deputy Director may approve an exception to the season of diversion criterion for all or part of an application if the application is for a storage project and the Deputy Director finds that (1) the applicant's existing diversions under another valid basis of right will be reduced as a result of the applicant's ability to divert to storage, and (2) the benefit to fishery resources of the reduction in diversions outweighs the potential impacts to fishery resources of the storage project.*
- *Persons who divert water under any legal basis of right, including riparian and permitted and licensed water rights, may petition the State Water Board pursuant to Water Code section 1707 for a "change for purposes of preserving or enhancing wetlands habitat, fish and wildlife resources, or recreation in, or on, the water." The section 1707 petition may be coupled with an application for a water right or a petition to amend an existing permit or license in order to modify an existing project so that diversion will occur in a manner that minimizes impacts to fish and wildlife. For example, a riparian right holder may file an application for offstream winter storage in lieu of summertime riparian direct diversion coupled with a petition to dedicate riparian flows under section 1707.*

*The Deputy Director may approve an exception to one or more of the diversion criteria for all or part of an application if the Deputy Director finds that (1) the applicant's existing diversions under another valid basis of right will be reduced if the application is approved, and (2) the benefit to fishery resources of the reduction outweighs the potential impacts to fishery resources if the application is approved.*

*Other changes that result in enhanced conditions for fish and wildlife may include:*

1. removal of an artificial barrier to the migration of anadromous fish;
2. replacement of onstream storage with offstream storage;
3. relocation of a point of diversion to reduce impacts to aquatic resources;
4. changes to frost protection practices undertaken pursuant to an existing water right that improve habitat for aquatic resources (which could include moving a point of diversion, adding or expanding storage in order to reduce instantaneous demand during frost events, improving efficiency, or implementing alternative frost protection techniques); and
5. other activities that have the effect of creating fish and wildlife habitat with improved stream flows.

*The State Water Board will expedite, where feasible, processing of petitions that will result in enhanced conditions for fish and wildlife, including section 1707 petitions and any water right applications or petitions to amend existing permits or licenses that accompany them. Expedited water right processing may occur if the following conditions are met:*

1. Documentation is provided showing the change will enhance conditions for fish and wildlife, including proof of past riparian use, if relevant;
2. The petitioner or applicant consults with other agencies, including DFG, NMFS, the Regional Water Quality Control Boards, and other agencies with jurisdictional authority, and the agencies provide written approval or support for the proposed change;
3. The proposed change is consistent with the principles of this policy; and
4. For water right applications, (1) a water availability analysis is submitted pursuant to Water Code section 1375, subdivision (d) that takes into account the face value demand of all known senior diversions, including senior pending water rights, and (2) the applicant agrees to conditions of approval that will ensure that the water that is the subject of the section 1707 petition will remain instream for purposes of protecting wetlands habitat, fish and wildlife resources, or recreation in or on the water.

Under these provisions, the grower would still need to spend considerable funds to provide the analysis required for a change in his or her water right even when the only reason for the change is an environmental improvement.

There are a number of other issues the environmental improvement project section of the policy brings up. The reliability of the water users' supply can be reduced. For example, a commonly recommended enhancement project is to forgo a riparian right with direct diversion during the dry growing season for an appropriative right with winter diversion and storage. The new appropriation cannot affect the water supply of any senior diverters; the practical effect of this change is to abandon a senior riparian right in favor of the most junior of rights on the subject waterway.

A water right environmental improvement option that is not discussed in the policy is to authorize the construction of regulatory storage ponds for riparian right holders for use during frost protection season (typically March 15 to May 15). The effect of riparian frost water diversions on stream flow would be reduced through the use of a pond refilled by a slow daytime diversion and/or a well and temporary storage (regulation) of the water for 30 to 60 days. Under this option the grower would still have a senior water right. The grower would need to keep detailed records of the



filling and use of the water in the regulatory pond and any excess water released at the end of the regulatory storage term.

The environmental improvement section of the policy also suggests that growers give up other water rights in order to get exceptions to the season of diversion when revising a water right. The first paragraph states for storage projects that if diversions under another valid basis of right are reduced the Deputy Director can change the season of diversion for the storage project. If a grower has riparian rights which are part of the ownership of property along streams and rivers as well as a permitted or licensed appropriative right, the grower may need to give up their riparian right in order to build and use a storage reservoir for the appropriative right even when the only reason for the reservoir is environmental improvement. These requirements will reduce the volume and reliability of the grower's water supply as well as possibly cause them to lose a senior water right. These types of requirements serve as a disincentive to change.

There are provisions in the Policy for watershed based approaches to water rights. As described in the policy:

*“The State Water Board recognizes that a watershed approach for determining water availability and evaluating environmental impacts of multiple water diversions in a watershed may be an alternative to evaluating individual projects using the regionally protective criteria set forth in this policy. Accordingly, flexibility should be provided to groups of diverters who endeavor to work together to allow for cost sharing, real-time operation of water diversions, and implementation of mitigation measures, as long as the proposed approaches are consistent with the principles for maintaining instream flows.*

*The policy encourages two alternative forms of watershed-based approaches: coordinated management of diversions through watershed charters and coordinated permitting of applications.*

*The watershed charter approach involves the formation of watershed groups to coordinate the development of technical information for coordinated water right permitting and/or for the coordination of diversion operations. Coordinated water right permitting allows the use of one package of technical documents for all pending applications within the watershed group. Coordinated operation of diversions and implementation of mitigation measures may be proposed through diversion management plans. Depending on the water right priority of the projects involved in a watershed group, participants in a watershed approach may receive expedited environmental review of water right applications. Individual water right permits will be issued for any improved applications that are part of a watershed group, provided that individual applicants accept permit conditions.*

*The watershed group shall provide the technical information necessary for the State Water Board to (1) determine water availability, (2) satisfy the requirements of CEQA (if applicable), (3) evaluate the potential impacts of water appropriation on public trust resources, (4) make decisions on whether and how to approve pending water right applications for diverters in the watershed group, and (5) make decisions on whether to approve proposed diversion management plans.*

*The watershed group shall perform technical work and submit technical documents as*

*described below:*

*1. Site-specific studies. The watershed group shall perform site-specific studies evaluating the instream flow needs of fish and fish habitat using the site-specific study guidance contained in this policy. After study completion, the watershed group shall submit a report detailing the results of the study to the State Water Board for review and approval. DFG consultations may occur.*

*2. Environmental documents. The watershed group shall submit information necessary to prepare appropriate environmental documents so that the State Water Board may make a determination of the impacts of the proposed projects to the environment, public trust, and the public interest for the purposes of preparing water right permits for the proposed projects. At a minimum, this information shall include (1) an evaluation of water availability, (2) descriptions of the significance of the potential impacts of the proposed projects caused by reductions in stream flow and/or the presence of onstream dams, (3) descriptions of proposed mitigation measures for impacts identified as potentially significant, (4) information needed for draft initial studies or other CEQA documents, and (5) an evaluation of the potential impacts of the proposed projects on public trust resources. All documents are subject to State Water Board review and approval. The analysis of water availability shall take into consideration diversions by member diverters and non-member diverters in the watershed. The watershed group shall work with regulatory agencies, as necessary, including NOAA Fisheries, the US Army Corps of Engineers, DFG, the State Water Board, and the North Coast Regional Water Quality Control Board to obtain regulatory approvals, assurances and/or permits under the ESA and CESA and state and federal water quality laws and regulations. CEQA and other environmental reviews of pending applications in the watershed group shall be coordinated to the extent possible. Technical documents prepared by the watershed groups shall be considered elements of the pending applications and, along with the applications, shall be subject to public notice and review and comment by responsible agencies and the public.*

*3. Diversion Management Plans. Diversion management plans shall be prepared if the watershed group proposes to coordinate operation of diversions and/or implementation of mitigation measures. Diversion management plans are not needed if the watershed group proposes only to coordinate the development of technical information for the permitting process. Watershed management plans shall describe: (a) how diversions will be operated to achieve compliance with stream flow requirements for the protection of fishery resources developed in item 1, above; (b) how diversions will be monitored to demonstrate compliance is achieved, including monitoring and reporting methods; and (c) the mitigation measures that will be implemented, a time schedule for implementation, and how the watershed group will ensure that such measures are implemented. The diversion management plan shall include a certification that the watershed group has the financial resources to build, operate, maintain, and monitor the proposed projects consistent with the terms of any water right permits issued for the project(s) and shall provide proof of financial resources.*

*Diversion management plans shall be consistent with the general requirements of this policy and all appropriate federal, state, and local laws. The diversion management plan shall not propose actions that result in any diminishment of the State Water Board's authority to require or enforce conditions to protect fish and wildlife, other public trust resources, or*

*senior water right holders. Diversion management plans are subject to State Water Board review and approval, and may be incorporated as enforceable terms and conditions in State Water Board orders, decisions, permits, or licenses.”*

This approach could provide for a more flexible and effective method for coordinating water diversions on tributaries to protect instream flow. However, some growers with licensed rights or riparian rights are unlikely to risk their water rights even if other growers are willing to do so. This provision of the policy provides no incentives for groups of growers to work together to coordinate diversions unless all the growers have pending applications for water rights. Additionally this provision is unlikely to generate watershed groups or coordinate diversions due to the large expense of completing all the studies.

### **Fish and Game Code Section 1600 Streambed Alteration Agreements**

Provisions of a permitted or licensed water right can be altered by a Lake and Streambed Alteration Agreement (LSAA) issued by the California Department of Fish and Game (CDFG) in accordance with Fish and Game Code section 1602I:

*Fish and Game Code (Section 1600 et. seq.) requires an entity to notify the Department of any proposed activity that may substantially modify a river, stream, or lake. This would likely include activities such as placing a pump intake into the surface flow of a stream, excavating material from channels to install and submerge a pump intake, and diverting water (including subterranean flow from off-channel wells) which may influence the amount of surface water available for fish and other aquatic species. Water diverters that do not have a valid Lake and Streambed Alteration Agreement (“LSAA”) should notify DFG of their projects prior to beginning annual water diversion activities (Ca. Department of Fish and Game 2009).*

CDFG has not adopted any specific regulations or guidance documents for this permit program. Nevertheless, CDFG staff assert that all water diversions from a stream, even those that do not physically modify the streambed, require an LSAA. CDFG staff also regularly insist on the inclusion of a minimum bypass flow requirement in LSAA despite the lack of an approved methodology to be used by CDFG staff to determine needed instream flows as part of LSAA reviews. This lack of published regulatory guidance creates uncertainty for the grower. It is also not clear how CDFG permit review is related to the Water Board permit analysis. Although CDFG requires that all diverters need to have an LSAA, there is limited enforcement and more importantly very limited staff to process LSAAAs.

### **Use of Recycled Water**

A future potential source of water for frost control is municipal recycled water and winery process water. Off-stream storage reservoirs to store the water and a system of pipelines to distribute the water are needed. The capital cost of these improvements can be very high. In Napa, there are two locations where these projects are being developed – the MST groundwater deficient area and the Carneros region.

Use of recycled water requires compliance with State and Federal water quality regulations. These regulations restrict the movement of recycled water off the site into waterways. A grower storing

and using recycled water has to avoid any overflow from the storage reservoir or sheet flow from the vineyard. If these events occur, the grower can be subject to third party lawsuits and fines from the Regional Water Quality Control Board.

## **Summary**

Institutional barriers to implementing alternative frost control measures are very high for most changes to water source facilities and water rights and very low for implementing in-vineyard water demand management measures or BMPs. It is possible to implement water demand reductions through the application of BMPs in vineyards without permits. These BMPs are now part of the Fish Friendly Farming Program and are part of the certification process.

Currently there are no studies in the Napa River Watershed that demonstrate that the use of water for frost control has a deleterious effect on stream flow. There are also no studies in the Napa or Russian River watersheds indicating that agricultural onstream reservoirs delay the timing of connected stream flow between the river and its tributaries as is assumed under the SWRCB Instream Flow Policy. The only way to determine if agricultural diversions cause flow impairments on tributaries is to implement a watershed wide synoptic monitoring program. This monitoring program would need to evaluate surface water diversions and groundwater use along with instream flows and subsurface water levels in a number of tributary basins. If problems are documented in a tributary, then changes should be analyzed relative to the timing and magnitude of flow in the Napa River. If a problem is identified, a group of landowners/managers can then work together to coordinate their diversions to improve instream flows.

Unless specific flow issues are identified, growers are unlikely to change water diversion facilities as the institutional barriers to changes in water rights created by the SWRCB Instream Flow Policy are enormous. An individual grower who wishes to revise a diversion or reservoir for the benefit of protecting instream flows would have to spend many hundreds of thousands of dollars in studies and CEQA compliance and may have to wait many years for the revision to be approved. Additionally, for changes to riparian rights, the grower could see the status of their water right reduced from senior to junior and the reliability of their water supply diminish. Even changes in licensed appropriative rights could require giving up riparian water rights again reducing the growers' water supply. The exception to this situation is the change from using surface water sources to groundwater as for most locations no water right permit is required. If a deep well located away from the creek can be drilled to replace a direct diversion, the grower can reduce effects on stream flow with a minimum of permitting or studies and potentially no reduction in the reliability of the water supply. However, in the MST area of Napa, new wells are not allowed.

It is unrealistic to expect any growers to voluntarily revise their permitted/licensed water rights due to the requirements of the Instream Flow Policy and potential for significant reductions in water supply reliability. Instead of assuming that diversions for frost control affect stream flow, a broad-based stream flow and groundwater monitoring program is needed. This program can evaluate agricultural water diversions in the Napa River Watershed where the timing and magnitude of stream flows are also affected by large municipal reservoirs, entrenchment of the Napa River into the alluvial basin and natural features like alluvial fans and determine if and where there is a problem. Then the involved growers can work to make needed revisions to protect instream flows.

## **INSTITUTIONAL ISSUES AFFECTING IMPLEMENTATION OF ALTERNATIVE FROST CONTROL METHODS**

Within a property or farm, it is relatively easy to change certain features of the frost control system. Installing additional weather stations or valves in vineyard blocks requires some additional capital expenditure but no permits. The water conservation calculator (Appendix 1) lists the costs of the various BMPs and allows a grower to review the cost/ac. ft. of water savings to determine the most effective scenario for a particular site. Revising the water facility or changing the water source can be both expensive to the grower and require a decade or more for permit approval.

Institutional issues affecting a grower's ability to implement alternative frost control measures include:

- Local government permitting requirements and restrictions for building various water supply facilities
- State water rights permitting system and instream flow policies
- Infrastructure and potential regulatory constraints on the use of recycled water

### **Local Requirements**

Certain revisions to water supply facilities require local government approval by Napa County. The building of an off-stream pond requires a county grading permit. An engineered plan with a soils and geology report and CEQA review is required for the grading permit. Additional studies may be needed for the CEQA review such as archaeological site review and rare plant surveys. In addition, a Floodplain Management Permit may be needed. Under the requirements for this permit, building a pond on the valley floor cannot impact riparian habitat, creek and river channels. The location of each pond has to be reviewed for effects on the direction or depth of flood water. In most locations, the off-stream pond will have to be developed from vineyard or fallow agricultural land, not wildland. Under both Federal and County regulations a new pond cannot increase flood hazards.

Drilling wells for agricultural water supply is regulated in one area of the valley – the Milliken-Sarco-Tulocay (MST) area (Figure 16). This groundwater basin has been declared deficient by Napa County due to declining groundwater levels. Between 2002-2009, static groundwater levels declined between 0 and 120 ft. (Napa County 2010). This groundwater basin is partially alluvium but primarily Sonoma Volcanic Formation. It is not part of the large Napa Valley alluvial groundwater basin.

In this area, vineyard use of groundwater is limited to 0.3 ac. ft./acre/year. This restriction is implemented through a requirement for a groundwater permit as part of a County erosion control plan for replanting an existing vineyard or developing a new vineyard. The grower is also required to meter their well and report water use to the Napa County Department of Public Works.

No other groundwater basin in Napa has declining groundwater levels and is regulated by Napa County. Surface water sources are not regulated by Napa County in the MST area.

There are planning efforts under way to develop the infrastructure to bring municipal recycled water from Napa Sanitation District for use in the MST area to reduce dependence on groundwater.

### **State Requirements**

The State of California regulates the diversion and use of surface water through the reasonable and beneficial use doctrine of Article X, Section 2 of the California Constitution, the public trust doctrine, Porter-Cologne Water Quality Control Act, water right permitting requirements, and other authorities that are enforced primarily by the State Water Resources Control Board (SWRCB). The SWRCB does not regulate groundwater in most areas.

### **Types of Water Rights**

California has a dual system of water rights which incorporates the riparian doctrine from English common law and the appropriative doctrine.

**Riparian water rights** are derived from owning land adjacent to a lake, creek or river and do not require a permit from the SWRCB. Riparian rights are not quantified; a riparian user is entitled to divert a reasonable quantity of the “natural” flow of the water source for beneficial purposes on the riparian land. In general, riparian water rights are senior to appropriative water rights for the same water body; water may be diverted for appropriative rights only after riparian uses have been satisfied. Riparian rights have the same priority and are “correlative” such that in times of water shortage all riparian uses must be reduced. Riparian rights are not lost due to a lack of use. Riparian water can be “regulated” in a reservoir, pond or tank for a short period of time (generally assumed to be 30 days or less) but cannot be “stored”. Starting in 2010, riparian water users are required to file a Statement of Water Diversion and Use to the SWRCB every three years.

**Appropriative water rights** are gained by the diversion and application of water to beneficial use and are not derived from ownership of land adjacent to a surface water body like riparian rights. Appropriate rights can be lost if non-use occurs for 5 years or more. Appropriative water rights are given priority by the date of their issuance.

Prior to 1914 and the passage of the State Water Code, appropriative water rights were claimed, posted and recorded in county records. Pre-1914 water rights are water rights claimed through this earlier process. Starting in 2010, pre-1914 appropriate water right holders are required to report water use to the SWRCB every three years.

After 1914, water may be appropriated only pursuant to a permit issued by the SWRCB. Appropriative water right permits can authorize direct diversion (which includes regulation of water for 30 days or less) or storage (greater than 30 days) of a defined volume of water. Permits specify the precise location where water may be diverted (point of diversion or POD), the specific uses of the water (e.g., irrigation, domestic, etc.) and the location where the water may be used, the diversion period (season), and the rate and volume of water diversion. Once a permit has been issued, the diversion and/or storage facility has been built and the water has been put to the intended beneficial use, a water right license can be issued. Water right permittees report their water use to the SWRCB in annual progress reports. Licensees report in biennial reports.

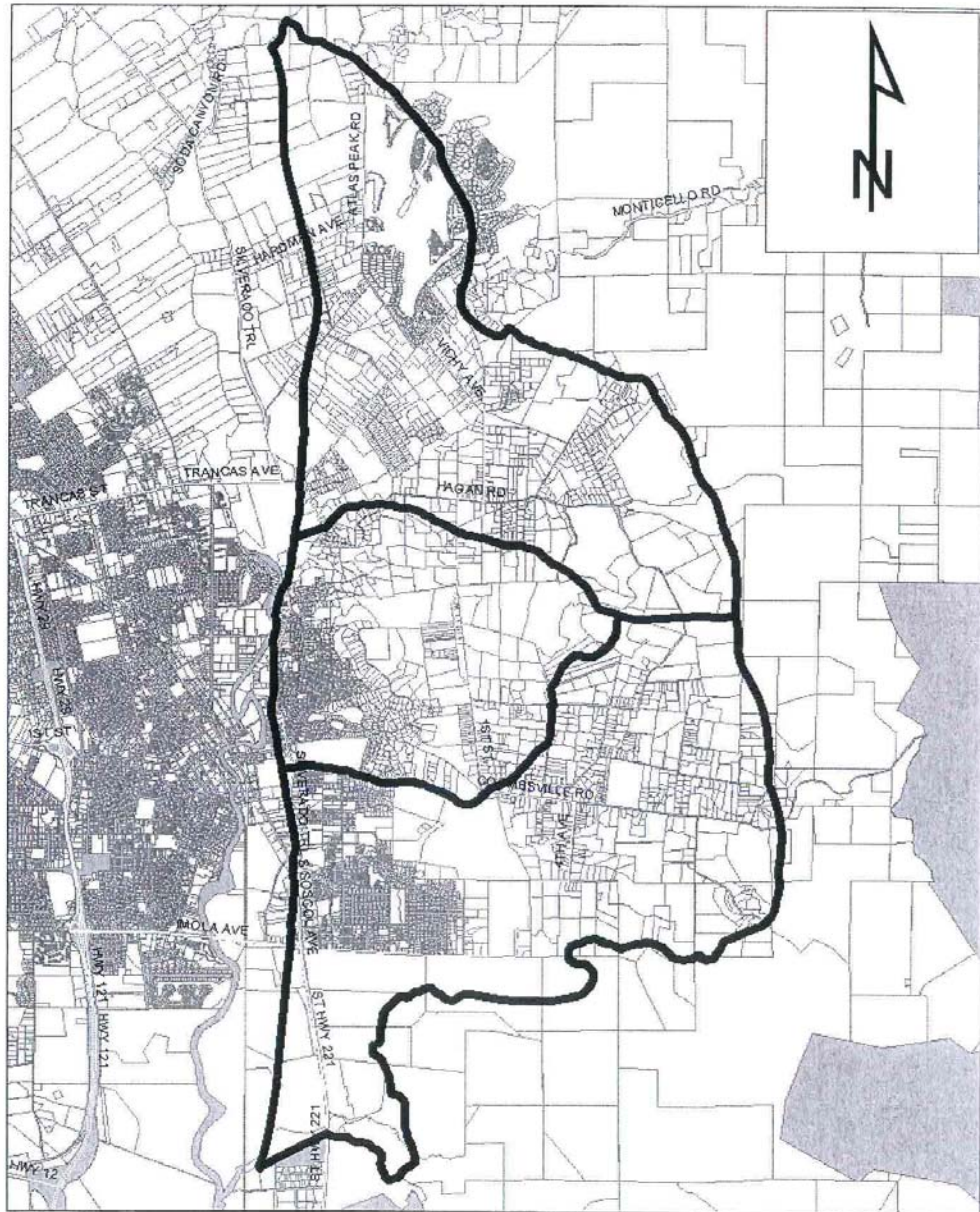

Map 13-1: Milliken Sarco Tulocay Groundwater Deficient Basin

Figure 16. Milliken Sarco Tulocay (MST) Groundwater Area

The water right permitting process has become complex, time consuming and costly for applicants. According to the SWCRB Diversion of Water Rights website, the steps in applying for an appropriative water right permit include:

- *Filing an Application. The process is initiated when a permit application is filed by the person or agency desiring to divert water. This application specifically describes the proposed project's source, place of use, purpose, point(s) of diversion and quantity to be diverted.*
- *Acceptance of Application. The Board notifies the applicant within 30 days whether the application is incomplete or accepted. Acceptance establishes priority as the date of filing.*
- *Public Notice. The State Board then publishes a notice of the applicant's intent and invites comment. Copies of any protests are given to the applicant who is required to respond.*
- *Environmental Review. Consideration of environmental effects is required by the California Environmental Quality Act before a permit can be issued. Large projects that could endanger or degrade natural habitat or water quality usually require preparation of an Environmental Impact Report. The Board examines the proposed project's potential environmental impacts and determines whether conservation measures will be needed.*
- *Protest Resolution. The State Board takes actions to resolve any protests that have been filed. If both parties can agree to mutually acceptable conditions, the protest is resolved at this point in the process. In the event it is not resolved for small projects, the issue may be solved through an engineering field investigation report from the Board's Division of Water Rights. For appeals from the report and or large projects, a formal hearing is held before one or more members of the State Board. The Board's decision is based upon the record produced by the hearing.*
- *Permit Issuance. Two initial Board findings are required before a permit can be issued: that unappropriated water is available to supply the applicant, and that the applicant's appropriation is in the public interest, a concept that is an overriding concern in all Board decisions. The permit is then issued if the Board determines that the proposed use of water best meets these criteria. If it determines otherwise, conditions may be imposed to ensure they are satisfied or the application may be denied. In most cases, the applicant is required to begin project construction within two years of permit issuance.*

## **Napa River Watershed Water Rights**

According to the SWRCB Division of Water Rights database, Napa River Watershed has approximately 527 pending, permitted and licensed appropriative water rights (Table 7). These include six large municipal reservoirs and numerous small agricultural reservoirs and a total "face value"<sup>2</sup> 81,450 ac. ft. of water. Figure 17 depicts these appropriative water rights by subwatershed in the Napa River basin. These rights which include storage are marked with an "S". Of the 527 appropriative water rights, only 23 are pending applications.

## **Napa River Watermaster Program**

Water diversions from the Napa River for frost control are controlled through the watermaster program of the Department of Water Resources. The SWRCB in 1972 adopted a regulation declaring

---

<sup>2</sup> The face value of a water right is the maximum quantity authorized for diversion under a permit or license. The face value is often much greater than actual water use, and accordingly, the face value total overstates actual water use in the Napa River Watershed.



that all significant direct diversions of water from the Napa River stream system between March 15 and May 15 are “unreasonable” and a violation of Water Code Section 100 except for diversions to replenish storage that are controlled by a watermaster administering a board or court approved distribution program. In 1974, the SWRCB sued riparian water users who refused to discontinue direct diversions during the frost season. The riparian users asserted that direct diversion was a reasonable exercise of riparian rights over which the State had no jurisdiction. This regulation and the Trial Distribution watermaster program were upheld by a court judgment in 1976 called the Forni Decision. The watermaster directs the timing of diversions from the Napa River for frost control. Each diversion is required to have a meter and growers must provide access and information to the watermaster. The growers directly divert or fill their off-stream reservoirs as directed by the watermaster. In low water years, water is allocated to the riparian right holders according to acres of vineyard. Appropriative right holders are allocated water only once the riparian right holders’ needs are met. The cost of the watermaster is billed to all of the participants (Ca. Department of Water Resources 2008).

### **North Coast Instream Flow Policy**

In May 2010, the SWRCB adopted a policy to govern new and pending appropriative water right permits and certain changes to permitted and licensed water rights (SWRCB 2010). This policy was formulated in response to Assembly Bill 2121 passed in 2004. The policy outlines methods for analyzing the effects of pending and new appropriative water right applications on anadromous salmonids in 3.1 million acres of coastal streams in portions of five counties including the Napa River Watershed.

This policy contains a new methodology for evaluating water flows and a very strict set of environmental requirements for pending and new appropriative water right applications and petitions. Most of the appropriative water rights in the Napa River Watershed (Table 7) are permitted or licensed and this policy would not directly affect them. However, if a grower wants to change his or her water source, method of diversion, place of use, operation of the diversion facility, point of diversion or obtain an extension of time of a permit to construct facilities or use more water, this new policy applies to the application, or petition, for the revision of the water right even if the only reason for the revision is environmental improvement.

The policy adopts five new principles or restrictions on new permits and amended permits and licenses:

6. *Water diversions shall be seasonally limited to periods in which instream flows are naturally high to prevent adverse effects to fish and fish habitat (Dec 15-March 31);*
7. *Water shall be diverted only when stream flows are higher than the minimum instream flows needed for fish spawning, rearing, and passage;*
8. *The maximum rate at which water is diverted in a watershed shall not adversely affect the natural flow variability needed for maintaining adequate channel structure and habitat for fish;*
9. *The cumulative effects of water diversions on instream flows needed for the protection of fish and their habitat shall be considered and minimized; and*

10. *Construction or permitting of new onstream dams shall be restricted. When allowed, onstream dams shall be constructed and permitted in a manner that does not adversely affect fish and their habitat.*

The policy principles are primarily designed to protect salmonid fishes and the policy requirements apply to every stream within the Napa River Watershed including streams that do not support salmonids.

The policy principles are implemented through regional criteria, which are a suite of general requirements including numeric bypass flow requirements derived from conservative equations, or site specific criteria tailored to the specific project that are developed through site specific studies.

Applicants are required to prepare all of the studies needed to evaluate the effects of the diversion and how it meets the policy requirements. The majority of Napa's appropriative water rights for both agricultural and municipal use were issued prior to modern environmental review laws. The policy studies include: Water Availability Analysis with a Water Supply Report, Upper Limit of Anadromy Determination, Cumulative Diversion Analysis, and Site Specific Studies to identify instream flow needs at locations at or below anadromy. Each of these studies and reports has detailed requirements.

The Water Supply Report has to include:

8. *A map showing the locations of the points of diversion (PODs) of senior priority water right holders and water right claimants in the watershed.*
9. *A list of all senior priority water rights (permit, license, certificate, or registration), their seasons of diversion, and face values of their permits or licenses. To the extent information is available in the State Water Board's records, or other sources of information, the demand and season of diversion of riparian and pre- 1914 appropriative water right holders and claimants should also be included;*
10. *Unimpaired flows may be estimated either through an adjustment of stream flow records method or through the use of a precipitation-based stream flow model. If reference stream flow gages are used in the analysis, the water supply report shall include a description of the reasons why the selected stream flow gage is appropriate for use in the analysis.*
11. *A tabulation of the estimated percentages of unappropriated water supply available at the POD for each senior priority water right on the water flow path after accounting for senior demands. This percentage may be obtained using estimates of the unimpaired flow volume of the stream at each senior POD and the seasonal demand volumes of the senior water right holders. The seasonal demand volume is the sum of the demand volumes of the senior water right holders with the right to divert water during the proposed project's diversion season that are within the watershed upstream of identified senior PODs along the water flow path. The demand volume shall be determined using the face value or maximum annual use limitation of each water right; however there may be diversions for which proration of face values or maximum annual use limitations may be appropriate.*

12. *A calculation of the ratio of the proposed project's demand to the remaining unappropriated water supply at each identified senior POD. This analysis is needed for the purposes of (1) identifying locations where the proposed project is likely to have minimal impacts to the rate of flow, and (2) to assist with selection of points of interest for the cumulative diversion analysis. The ratio shall be obtained by dividing the proposed project's water demand volume by the remaining unappropriated water supply at each senior POD.*
13. *A flow frequency analysis of the seasonal unimpaired flow volume. A set of flow frequency analyses shall be provided at the POD(s) of the proposed project, the senior POD at which the percentage calculated in step 3 is the lowest, and any other senior PODs at which the ratio is less than 50%, if any. The frequency of occurrence of the average seasonal unimpaired flow volumes for each year of record should be determined and plotted graphically.*

The determination of the Upper Limit Anadromy is required regardless of the location of the project. This study has to include:

1. *A study, previously accepted by the State Water Board, National Marine Fisheries Service (NMFS), or (California Department of Fish and Game) DFG, that identifies the location of the upper limit of anadromy on the stream reach between the POD and the Pacific Ocean or to a flow-regulated mainstem river, depending on the water flow path. Previous studies or surveys that catalog only the presence or absence of anadromous fish might not accurately define the upper limit of anadromy.*
2. *Information demonstrating that the gradient of a segment of the stream reach between the POD and Pacific Ocean or to a flow-regulated mainstem river, depending on the water flow path, exceeds a continuous longitudinal slope over a distance of large enough magnitude that anadromous fish cannot move upstream beyond the lowest point of the gradient. The gradient shall be a continuous longitudinal slope of 12%, or greater, over a distance of 330 feet along the stream.*
3. *Site-specific studies conducted by a qualified fisheries biologist. The applicant may refer to stream classification determinations for preliminary refinement of the geographic extent of the site-specific study. Prior to conducting the site-specific study, the name(s) and qualifications of the individual(s) selected to perform the studies shall be submitted to the State Water Board for review and approval. All field work, modeling, analysis, and calculations performed as part of this study shall be documented in detail sufficient to withstand credible peer review. The site specific studies shall consist of any of the following:*
  - a. *Identification of an impassable natural waterfall. This policy assumes all natural waterfalls are passable unless the applicant provides information satisfactory to the State Water Board that the waterfall is impassable. This information shall include, at a minimum, an evaluation of waterfall drop height, leaping angle, and pool depth in comparison to the documented ability for the target anadromous fish species to successfully ascend the barrier.*
  - b. *Identification of an impassable human-caused barrier. The applicant may choose to demonstrate that the upper limit of anadromy is located below a human-caused barrier such as a dam, culvert, or bridge. This policy assumes that all human-caused*

*barriers are passable or can be made passable unless the applicant provides information satisfactory to the State Water Board that a man-made barrier is impassable and will never be made passable.*

*c. Habitat-based stream survey that delineates the upper limit of anadromy based on quantifiable stream conditions*

- 4. The stream survey shall extend an appropriate distance within the stream channel. In general, a minimum distance of 25 bankfull widths upstream and downstream of the POD and a total stream survey length of a minimum of 50 bankfull widths will capture the variability within a given stream.*
- 5. Quarterly surveys using appropriate sampling and/or collection equipment shall be conducted to determine the presence of fish, aquatic non-fish vertebrates, and/or aquatic benthic macroinvertebrates. These surveys shall be conducted in the spring, summer, fall, and winter, for at least two years; unless it is demonstrated that the presence of fish, aquatic non-fish vertebrates, and/or aquatic benthic macroinvertebrates can be determined in a shorter time period.*
- 6. A survey of instream habitat conditions shall be made at low flows during the diversion season. Examples of instream habitat condition metrics that could be measured include:
  - i. Mean residual pool depth*
  - j. Mean riffle crest depth*
  - k. Mean riffle width*
  - l. Mean channel bankfull width*
  - m. Mean channel longitudinal gradient*
  - n. Water temperature*
  - o. Amount and type of cover*
  - p. Substrate type**
- 7. A visual survey shall be made after a storm runoff event for evidence of sediment transport. Such evidence may include, but is not limited to, the presence of gravel bars and deposits composed of gravel and sand. Annotated photographs must be provided for documentary evidence.*

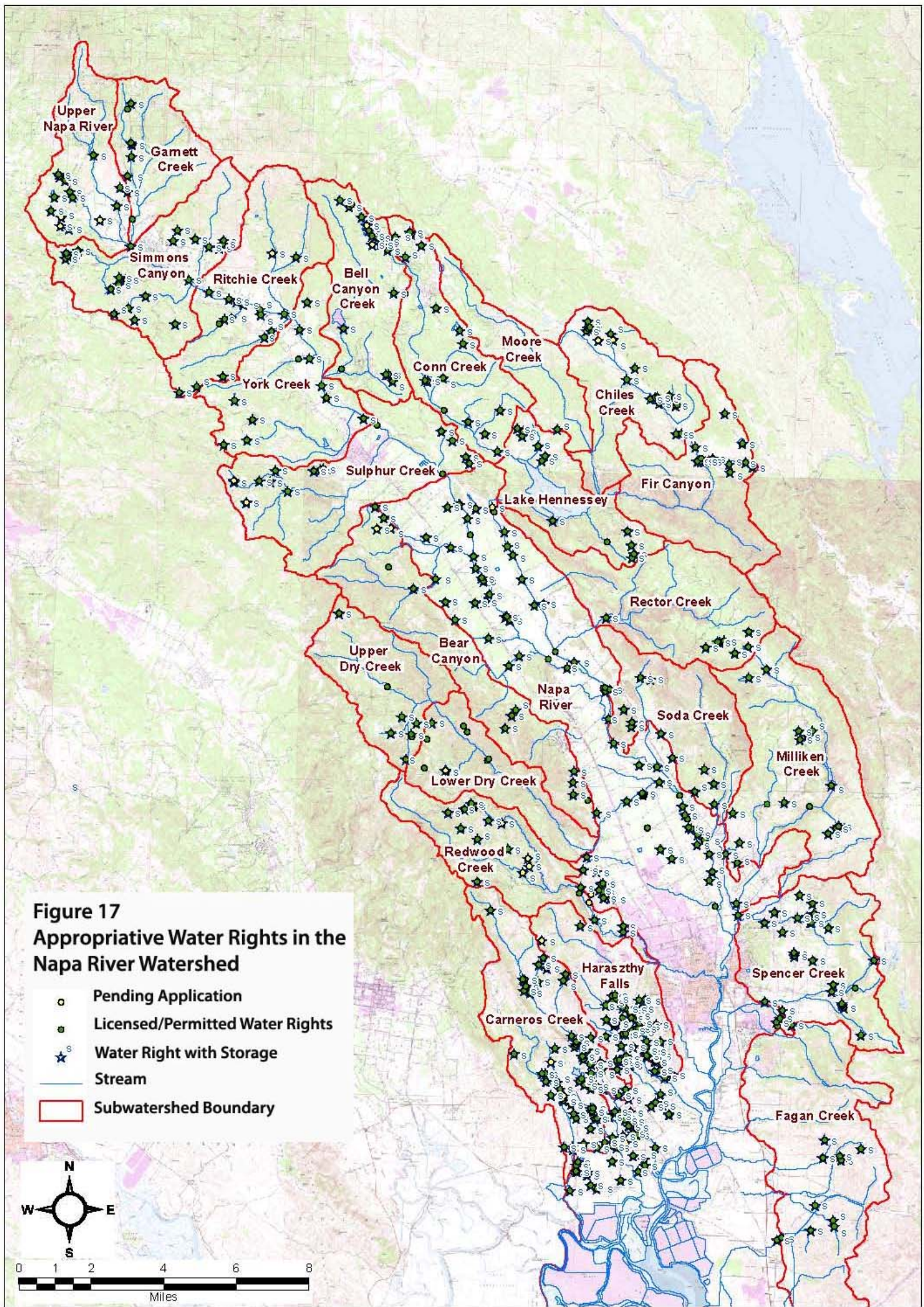

**Table 7. Appropriative Water Rights in the Napa River Watershed for Agricultural and Municipal Uses**

	<b>Subwatershed</b>	<b>Number of Appropriate Water Rights</b>	<b>Face Value of Water Right</b>	<b>Acres of Subwatershed</b>
571	Upper Napa River	14	1851.5	6,177
	Licensed	11	942.8	
	Pending	2	51.7	
	Permitted	1	857	
575	Garnett Creek	7	101.8	5,088
	Licensed	6	73.8	
	Permitted	1	28	
592	Simmons Canyon	19	245.4	8,553
	Licensed	16	175.4	
	Permitted	3	70	
595	Ritchie Creek	16	447.5	8,768
	Licensed	11	275.5	
	Pending	1	15	
	Permitted	4	157	
599	Bell Canyon Reservoir	35	5973.4	6,830
	Licensed	22	827.9	
	Pending	2	205	
	Permitted	11	4940.5	
605	Conn Creek	15	766.1	7,297
	Licensed	9	270.1	
	Permitted	6	496	
607	Moore Creek	1	1.3	4,819
	Licensed	1	1.3	
611	York Creek	15	231.4	8,444
	Licensed	14	182.4	
	Permitted	1	49	
616	Chiles Creek	13	441.5	7,293

**Table 7. Appropriative Water Rights in the Napa River Watershed for Agricultural and Municipal Uses**

	<b>Subwatershed</b>	<b>Number of Appropriate Water Rights</b>	<b>Face Value of Water Right</b>	<b>Acres of Subwatershed</b>
	Licensed	10	322.5	
	Pending	2	98	
	Permitted	1	21	
624	Fir Canyon	14	683	8,195
	Licensed	2	110	
	Permitted	12	573	
627	Heath Canyon	15	521.3	10,141
	Licensed	8	258.3	
	Pending	2	70	
	Permitted	5	193	
632	Lake Hennessey	16	43553.6	5,761
	Licensed	8	140.7	
	Permitted	8	43412.9	
642	Napa River	131	9648.1	82,199
	Licensed	82	3078.5	
	Pending	7	204	
	Permitted	42	6365.6	
643	Rector Reservation	8	4679	9,325
	Licensed	3	3554	
	Permitted	5	1125	
644	Bear Canyon	12	1913.2	9,377
	Licensed	5	54.9	
	Pending	1	52	
	Permitted	6	1806.3	
654	Upper Dry Creek	8	77.6	6,107
	Licensed	7	47.6	
	Permitted	1	30	
656	Milliken Reservoir	22	6098.1	12,439
	Licensed	16	2641.1	

**Table 7. Appropriative Water Rights in the Napa River Watershed for Agricultural and Municipal Uses**

	<b>Subwatershed</b>	<b>Number of Appropriate Water Rights</b>	<b>Face Value of Water Right</b>	<b>Acres of Subwatershed</b>
	Permitted	6	3457	
658	Soda Creek	9	187.8	7,070
	Licensed	7	108.8	
	Permitted	2	79	
665	Lower Dry Creek	7	59	5,679
	Licensed	5	14	
	Pending	1	15	
	Permitted	1	30	
669	Redwood Creek	18	355.7	6,975
	Licensed	9	150.7	
	Pending	3	79	
	Permitted	6	126	
679	Spencer Creek	28	723.7	9,035
	Licensed	25	479.7	
	Permitted	3	244	
680	Carneros Creek	49	2184	9,577
	Licensed	19	657	
	Pending	2	72	
	Permitted	28	1455	
683	Haraszthy Falls	46	1281.2	6,068
	Licensed	24	399	
	Pending	1	9.7	
	Permitted	21	872.5	
691	Fagan Creek	9	295.9	18,698
	Licensed	5	73.9	
	Permitted	4	222	
	<b>Grand Total</b>	527	82321.1	82199.2



Projects that cannot (or choose not to) satisfy one or more of the conservative regional criteria must prepare Site Specific Stream Studies to document the features of the stream and develop site specific criteria. Most of the site specific study methodologies identified in the policy apply to alluvial stream channels and some features described in the requirements such as riffle crest and bankfull width are not applicable to entrenched channels, bedrock and boulder or confined channels, alluvial fans and other stream features that are common in the Napa River Watershed.

The fourth requirement is a Cumulative Diversion Analysis. There is an assumption underlying the description of the requirements for this analysis that there are no impairments to stream flow except for other appropriative water rights. None of the existing natural and man-made limitations to connected flow, including alluvial fans, the entrenched river channel and alluvial basin are considered in the analysis.

*The Cumulative Diversion Analysis is required to evaluate whether or not the proposed project, in combination with senior diversions, adversely affects instream flows needed for the protection of fishery resources. In cases where the Cumulative Diversion Analysis demonstrates that the proposed project, in combination with senior diversions, significantly affects instream flows, water may not be available for appropriation.*

*The Cumulative Diversion Analysis requirements vary depending on the proposed project's location in the watershed. The analysis considers senior diversions in the watershed between the proposed project and the most downstream Point of Interest (POI), and contributory flows from tributaries draining into the flow path. Contributory flows from tributaries draining into the flow path can reduce the impacts of diversions in Class III or II watersheds on stream flows needed for fish in Class I streams. At points of diversion located above anadromy, the change in hydrology near the POD may appear significant. However, downstream, at and below the upper limit of anadromy, where salmonids can be affected, the change in hydrology can be slight. Depending on the hydrology and level of impairment in watersheds above anadromy, situations may exist in which diversions could operate with reduced or no minimum bypass flows and/or rates of diversion. The Cumulative Diversion Analysis allows projects upstream of anadromy to determine the minimum bypass flows and rates of diversion needed for their project by evaluating whether the project adversely affects instream flows needed for fishery resources where anadromy exists, after consideration of the flow reductions by senior diverters and contributory flows from stream tributaries. The Cumulative Diversion Analysis Reports shall include the following information:*

- 1. The minimum bypass flow and maximum rate of diversion that were used to achieve compliance with the cumulative diversion analysis requirements;*
- 2. The details of the minimum bypass flow and maximum cumulative diversion calculations for Points of Interest (POIs) located at and below anadromy, if regional criteria were used;*
- 3. Where needed, documentation of the site-specific studies that were performed to identify more precisely the instream flow needs of the fishery resources at the A-17 POIs located at and below anadromy;*

4. *The details of a daily analysis of the estimated effects of the proposed project and senior diversions on instream flows needed for spawning, rearing, and passage at each POI located at and/or below anadromy, including an evaluation of the number of days that instream flows meet or exceed the minimum bypass flow requirement at each POI located at and/or below anadromy for three flow conditions: unimpaired; impaired without the proposed project; and impaired with the proposed project. The report shall also include the average percent change by month over the period of record between the number of days flow exceeded the minimum bypass flow requirement and/or the February median flow bypass requirement in the unimpaired condition and the impaired condition. The percent change for the impaired condition shall be evaluated for both scenarios, senior diverters only and senior diverters with the proposed project;*

5. *The details of a daily analysis of the estimated effects of the proposed project and senior diversions on the natural flow variability of the stream at each POI located at and/or below anadromy, which consists of calculating the 1.5-year instantaneous peak flow for three flow conditions: unimpaired, impaired without the proposed project, and impaired with the proposed project, then either comparing these values against the maximum cumulative diversion criteria or comparing impaired conditions with and without the project.*

Once these studies are completed, a CEQA document must be prepared. Many projects will require mitigation including non-native species eradication, gravel and wood augmentation, or riparian habitat replacement. Projects with on-stream dams require a passive bypass system or automated computer-controlled bypass system. A monitoring program is also required.

The cost of preparing these reports and CEQA documents can be in excess of \$300,000, even for a 5-10 ac. ft. pond on a ridgetop well upstream of any salmonid habitat. Besides the reports required by the Instream Policy, the methods allowed for determining bypass flows involve a regional criteria which is controversial, being formulated from a very small dataset for the very large 3 million acre policy area. Additionally as noted previously, the natural features of river systems like the Napa and Russian Rivers include large alluvial valleys, alluvial fans and man-made alterations in the timing and magnitude of stream flow which the Instream Policy does not address. The required analysis does not take into account losses of stream flow to groundwater as occurs in the large alluvial valleys of the Napa and Russian Rivers. The implementation of bypass flows for a small agricultural water facility are required but are not analyzed in the larger watershed context of the timing of river flows affected by large municipal reservoirs and recharge of the alluvial basin. Many agricultural facilities may not affect connected flow needed for fish migration when compared to existing conditions in the Napa River Watershed.

In addition to the expense of preparing the reports required for a change in a water right there are also long delays. The SWRCB processes very few appropriative water rights permits each year. In 2009, a total of 10 permits were issued out of a backlog of 275 in Napa, Sonoma and Mendocino Counties (SWRCB 2010). There are a number of appropriative water right permits and petitions which were filed 10-20 years ago and have not yet been issued or denied. During that time, the SWRCB has changed its criteria and procedures for issuing water right permits multiple times. These long delays and changing criteria and procedures are significant barriers to changing an existing water right.

The Policy does include provisions to expedite, and in some cases exempt from policy diversion criteria, new water rights and changes to existing water rights that provide environmental improvements:

- *The Deputy Director may approve an exception to the season of diversion criterion for all or part of an application if the application is for a storage project and the Deputy Director finds that (1) the applicant's existing diversions under another valid basis of right will be reduced as a result of the applicant's ability to divert to storage, and (2) the benefit to fishery resources of the reduction in diversions outweighs the potential impacts to fishery resources of the storage project.*
- *Persons who divert water under any legal basis of right, including riparian and permitted and licensed water rights, may petition the State Water Board pursuant to Water Code section 1707 for a "change for purposes of preserving or enhancing wetlands habitat, fish and wildlife resources, or recreation in, or on, the water." The section 1707 petition may be coupled with an application for a water right or a petition to amend an existing permit or license in order to modify an existing project so that diversion will occur in a manner that minimizes impacts to fish and wildlife. For example, a riparian right holder may file an application for offstream winter storage in lieu of summertime riparian direct diversion coupled with a petition to dedicate riparian flows under section 1707.*

*The Deputy Director may approve an exception to one or more of the diversion criteria for all or part of an application if the Deputy Director finds that (1) the applicant's existing diversions under another valid basis of right will be reduced if the application is approved, and (2) the benefit to fishery resources of the reduction outweighs the potential impacts to fishery resources if the application is approved.*

*Other changes that result in enhanced conditions for fish and wildlife may include:*

- 1. removal of an artificial barrier to the migration of anadromous fish;*
- 2. replacement of onstream storage with offstream storage;*
- 3. relocation of a point of diversion to reduce impacts to aquatic resources;*
- 4. changes to frost protection practices undertaken pursuant to an existing water right that improve habitat for aquatic resources (which could include moving a point of diversion, adding or expanding storage in order to reduce instantaneous demand during frost events, improving efficiency, or implementing alternative frost protection techniques); and*
- 5. other activities that have the effect of creating fish and wildlife habitat with improved stream flows.*

*The State Water Board will expedite, where feasible, processing of petitions that will result in enhanced conditions for fish and wildlife, including section 1707 petitions and any water right applications or petitions to amend existing permits or licenses that accompany them. Expedited water right processing may occur if the following conditions are met:*

- 1. Documentation is provided showing the change will enhance conditions for fish and wildlife, including proof of past riparian use, if relevant;*

2. *The petitioner or applicant consults with other agencies, including DFG, NMFS, the Regional Water Quality Control Boards, and other agencies with jurisdictional authority, and the agencies provide written approval or support for the proposed change;*
3. *The proposed change is consistent with the principles of this policy; and*
4. *For water right applications, (1) a water availability analysis is submitted pursuant to Water Code section 1375, subdivision (d) that takes into account the face value demand of all known senior diversions, including senior pending water rights, and (2) the applicant agrees to conditions of approval that will ensure that the water that is the subject of the section 1707 petition will remain instream for purposes of protecting wetlands habitat, fish and wildlife resources, or recreation in or on the water.*

Under these provisions, the grower would still need to spend considerable funds to provide the analysis required for a change in his or her water right even when the only reason for the change is an environmental improvement.

There are a number of other issues the environmental improvement project section of the policy brings up. The reliability of the water users' supply can be reduced. For example, a commonly recommended enhancement project is to forgo a riparian right with direct diversion during the dry growing season for an appropriative right with winter diversion and storage. The new appropriation cannot affect the water supply of any senior diverters; the practical effect of this change is to abandon a senior riparian right in favor of the most junior of rights on the subject waterway.

A water right environmental improvement option that is not discussed in the policy is to authorize the construction of regulatory storage ponds for riparian right holders for use during frost protection season (typically March 15 to May 15). The effect of riparian frost water diversions on stream flow would be reduced through the use of a pond refilled by a slow daytime diversion and/or a well and temporary storage (regulation) of the water for 30 to 60 days. Under this option the grower would still have a senior water right. The grower would need to keep detailed records of the filling and use of the water in the regulatory pond and any excess water released at the end of the regulatory storage term.

The environmental improvement section of the policy also suggests that growers give up other water rights in order to get exceptions to the season of diversion when revising a water right. The first paragraph states for storage projects that if diversions under another valid basis of right are reduced the Deputy Director can change the season of diversion for the storage project. If a grower has riparian rights which are part of the ownership of property along streams and rivers as well as a permitted or licensed appropriative right, the grower may need to give up their riparian right in order to build and use a storage reservoir for the appropriative right even when the only reason for the reservoir is environmental improvement. These requirements will reduce the volume and reliability of the grower's water supply as well as possibly cause them to lose a senior water right. These types of requirements serve as a disincentive to change.

There are provisions in the Policy for watershed based approaches to water rights. As described in the policy:

*“The State Water Board recognizes that a watershed approach for determining water availability and evaluating environmental impacts of multiple water diversions in a watershed may be an alternative to evaluating individual projects using the regionally*

*protective criteria set forth in this policy. Accordingly, flexibility should be provided to groups of diverters who endeavor to work together to allow for cost sharing, real-time operation of water diversions, and implementation of mitigation measures, as long as the proposed approaches are consistent with the principles for maintaining instream flows.*

*The policy encourages two alternative forms of watershed-based approaches: coordinated management of diversions through watershed charters and coordinated permitting of applications.*

*The watershed charter approach involves the formation of watershed groups to coordinate the development of technical information for coordinated water right permitting and/or for the coordination of diversion operations. Coordinated water right permitting allows the use of one package of technical documents for all pending applications within the watershed group. Coordinated operation of diversions and implementation of mitigation measures may be proposed through diversion management plans. Depending on the water right priority of the projects involved in a watershed group, participants in a watershed approach may receive expedited environmental review of water right applications. Individual water right permits will be issued for any improved applications that are part of a watershed group, provided that individual applicants accept permit conditions.*

*The watershed group shall provide the technical information necessary for the State Water Board to (1) determine water availability, (2) satisfy the requirements of CEQA (if applicable), (3) evaluate the potential impacts of water appropriation on public trust resources, (4) make decisions on whether and how to approve pending water right applications for diverters in the watershed group, and (5) make decisions on whether to approve proposed diversion management plans.*

*The watershed group shall perform technical work and submit technical documents as described below:*

*1. Site-specific studies. The watershed group shall perform site-specific studies evaluating the instream flow needs of fish and fish habitat using the site-specific study guidance contained in this policy. After study completion, the watershed group shall submit a report detailing the results of the study to the State Water Board for review and approval. DFG consultations may occur.*

*2. Environmental documents. The watershed group shall submit information necessary to prepare appropriate environmental documents so that the State Water Board may make a determination of the impacts of the proposed projects to the environment, public trust, and the public interest for the purposes of preparing water right permits for the proposed projects. At a minimum, this information shall include (1) an evaluation of water availability, (2) descriptions of the significance of the potential impacts of the proposed projects caused by reductions in stream flow and/or the presence of onstream dams, (3) descriptions of proposed mitigation measures for impacts identified as potentially significant, (4) information needed for draft initial studies or other CEQA documents, and (5) an evaluation of the potential impacts of the proposed projects on public trust resources. All documents are subject to State Water Board review and approval. The analysis of water availability shall take into consideration diversions by member diverters and non-member diverters in the*

watershed. The watershed group shall work with regulatory agencies, as necessary, including NOAA Fisheries, the US Army Corps of Engineers, DFG, the State Water Board, and the North Coast Regional Water Quality Control Board to obtain regulatory approvals, assurances and/or permits under the ESA and CESA and state and federal water quality laws and regulations. CEQA and other environmental reviews of pending applications in the watershed group shall be coordinated to the extent possible. Technical documents prepared by the watershed groups shall be considered elements of the pending applications and, along with the applications, shall be subject to public notice and review and comment by responsible agencies and the public.

*3. Diversion Management Plans. Diversion management plans shall be prepared if the watershed group proposes to coordinate operation of diversions and/or implementation of mitigation measures. Diversion management plans are not needed if the watershed group proposes only to coordinate the development of technical information for the permitting process. Watershed management plans shall describe: (a) how diversions will be operated to achieve compliance with stream flow requirements for the protection of fishery resources developed in item 1, above; (b) how diversions will be monitored to demonstrate compliance is achieved, including monitoring and reporting methods; and (c) the mitigation measures that will be implemented, a time schedule for implementation, and how the watershed group will ensure that such measures are implemented. The diversion management plan shall include a certification that the watershed group has the financial resources to build, operate, maintain, and monitor the proposed projects consistent with the terms of any water right permits issued for the project(s) and shall provide proof of financial resources.*

*Diversion management plans shall be consistent with the general requirements of this policy and all appropriate federal, state, and local laws. The diversion management plan shall not propose actions that result in any diminishment of the State Water Board's authority to require or enforce conditions to protect fish and wildlife, other public trust resources, or senior water right holders. Diversion management plans are subject to State Water Board review and approval, and may be incorporated as enforceable terms and conditions in State Water Board orders, decisions, permits, or licenses."*

This approach could provide for a more flexible and effective method for coordinating water diversions on tributaries to protect instream flow. However, some growers with licensed rights or riparian rights are unlikely to risk their water rights even if other growers are willing to do so. This provision of the policy provides no incentives for groups of growers to work together to coordinate diversions unless all the growers have pending applications for water rights. Additionally this provision is unlikely to generate watershed groups or coordinate diversions due to the large expense of completing all the studies.

### **Fish and Game Code Section 1600 Streambed Alteration Agreements**

Provisions of a permitted or licensed water right can be altered by a Lake and Streambed Alteration Agreement (LSAA) issued by the California Department of Fish and Game (CDFG) in accordance with Fish and Game Code section 1602I:

*Fish and Game Code (Section 1600 et. seq.) requires an entity to notify the Department of any proposed activity that may substantially modify a river, stream,*

*or lake. This would likely include activities such as placing a pump intake into the surface flow of a stream, excavating material from channels to install and submerge a pump intake, and diverting water (including subterranean flow from off-channel wells) which may influence the amount of surface water available for fish and other aquatic species. Water diverters that do not have a valid Lake and Streambed Alteration Agreement (“LSAA”) should notify DFG of their projects prior to beginning annual water diversion activities (Ca. Department of Fish and Game 2009).*

CDFG has not adopted any specific regulations or guidance documents for this permit program. Nevertheless, CDFG staff assert that all water diversions from a stream, even those that do not physically modify the streambed, require an LSAA. CDFG staff also regularly insist on the inclusion of a minimum bypass flow requirement in LSAA despite the lack of an approved methodology to be used by CDFG staff to determine needed instream flows as part of LSAA reviews. This lack of published regulatory guidance creates uncertainty for the grower. It is also not clear how CDFG permit review is related to the Water Board permit analysis. Although CDFG requires that all diverters need to have an LSAA, there is limited enforcement and more importantly very limited staff to process LSAA's.

### **Use of Recycled Water**

A future potential source of water for frost control is municipal recycled water and winery process water. Off-stream storage reservoirs to store the water and a system of pipelines to distribute the water are needed. The capital cost of these improvements can be very high. In Napa, there are two locations where these projects are being developed – the MST groundwater deficient area and the Carneros region.

Use of recycled water requires compliance with State and Federal water quality regulations. These regulations restrict the movement of recycled water off the site into waterways. A grower storing and using recycled water has to avoid any overflow from the storage reservoir or sheet flow from the vineyard. If these events occur, the grower can be subject to third party lawsuits and fines from the Regional Water Quality Control Board.

### **Summary**

Institutional barriers to implementing alternative frost control measures are very high for most changes to water source facilities and water rights and very low for implementing in-vineyard water demand management measures or BMPs. It is possible to implement water demand reductions through the application of BMPs in vineyards without permits. These BMPs are now part of the Fish Friendly Farming Program and are part of the certification process.

Currently there are no studies in the Napa River Watershed that demonstrate that the use of water for frost control has a deleterious effect on stream flow. There are also no studies in the Napa or Russian River watersheds indicating that agricultural onstream reservoirs delay the timing of connected stream flow between the river and its tributaries as is assumed under the SWRCB Instream Flow Policy. The only way to determine if agricultural diversions cause flow impairments on tributaries is to implement a watershed wide synoptic monitoring program. This monitoring program would need to evaluate surface water diversions and groundwater use along with instream flows and subsurface water levels in a number of tributary basins. If problems are documented in a

tributary, then changes should be analyzed relative to the timing and magnitude of flow in the Napa River. If a problem is identified, a group of landowners/managers can then work together to coordinate their diversions to improve instream flows.

Unless specific flow issues are identified, growers are unlikely to change water diversion facilities as the institutional barriers to changes in water rights created by the SWRCB Instream Flow Policy are enormous. An individual grower who wishes to revise a diversion or reservoir for the benefit of protecting instream flows would have to spend many hundreds of thousands of dollars in studies and CEQA compliance and may have to wait many years for the revision to be approved. Additionally, for changes to riparian rights, the grower could see the status of their water right reduced from senior to junior and the reliability of their water supply diminish. Even changes in licensed appropriative rights could require giving up riparian water rights again reducing the growers' water supply. The exception to this situation is the change from using surface water sources to groundwater as for most locations no water right permit is required. If a deep well located away from the creek can be drilled to replace a direct diversion, the grower can reduce effects on stream flow with a minimum of permitting or studies and potentially no reduction in the reliability of the water supply. However, in the MST area of Napa, new wells are not allowed.

It is unrealistic to expect any growers to voluntarily revise their permitted/licensed water rights due to the requirements of the Instream Flow Policy and potential for significant reductions in water supply reliability. Instead of assuming that diversions for frost control affect stream flow, a broad-based stream flow and groundwater monitoring program is needed. This program can evaluate agricultural water diversions in the Napa River Watershed where the timing and magnitude of stream flows are also affected by large municipal reservoirs, entrenchment of the Napa River into the alluvial basin and natural features like alluvial fans and determine if and where there is a problem. Then the involved growers can work to make needed revisions to protect instream flows



## REFERENCES

Ca. Department of Fish and Game. April 14, 2009. DRAFT Russian River Water Diversion Activities and Lake and Streambed Alteration Agreement Notification Requirements of the Department of Fish and Game.

Ca. Department of Water Resources. 2008. Order Creating Napa River Watermaster Service Area Napa County, Ca.

California Regional Water Quality Control Board San Francisco Bay Region. 2006. Napa River Sediment Total Maximum Daily Load. Staff Report.

Ca. State Water Resources Control Board. 2010. Policy for Maintaining Instream Flows in Northern California Coastal Streams.

Ca State Water Resources Control Board Division of Water Rights. 2010. Status of Pending Applications to Appropriate Water in the Counties of Marin, Napa, Sonoma, Mendocino and Humboldt.

Farrar, Christopher D. and Loren Metzger. 2003. Ground-water Resources in the Lower Milliken-Sarco-Tulocay Creeks Area, Southeastern Napa County, Ca 2000-2002. US Geological Survey Resource Investigation Report 03-4229.

Fox, Kenneth. 1983. Tectonic Setting of Late Miocene, Pliocene and Pleistocene Rocks in Part of the Coast Ranges north of San Francisco, CA. US Geological Survey Professional Paper 1239.

Helley, E, J, and K.R. LaJoie. 1979. Flatland deposits of the San Francisco Bay Region, Ca. - their geology and engineering properties and their importance to comprehensive planning. US Geological Survey Professional Paper 943.

Kunkel, Fred and J.E. Upton. 1960. Geology and Groundwater in Napa and Sonoma Valleys, Napa and Sonoma Counties, Ca. US Geological Survey Water Supply Paper 1995.

Mark Greenspan, Advanced Viticulture, *Frost Protection and Water Conservation*.

Napa Country Department of Public Works. July 2005. Groundwater Permits within the MST Groundwater Deficient Area.

Napa County Department of Public Works. 2010. MST Static Water Level Changes 2002-2009.

Snyder, R. L., 2000. Sprinkler Application Rates for Freeze Protection FP004 Quick Answer. Department of Land, Air and Water Resources, University of California, Davis.

Snyder, Richard L. 2001. Principles of Frost Protection. University of California, Davis.

Snyder, Richard and J. Paulo de Melo-Abreu. 2005. Frost Protection: fundamentals, practice and economics. Food and Agriculture Organization of the United Nations Rome.

Stillwater Sciences. 2002. Napa River Basin Limiting Factors Analysis.

Superior Court of State of California County of Napa. Dec 29 1976. Judgement NO 31785 granting permanent injunction case of State of California vs. Forni et al.

## **WEBSITES**

<http://ciwqs.waterboards.ca.gov/ewrims/ewrims> Water Rights Database

<http://www.adcon.com>

<http://www.cimis.water.ca.gov/cimis/data> California Irrigation Management Information System

<http://www.countyofnapa.org/Pages/DepartmentContent> Grading Permit Application

<http://www.countyofnapa.org/pages/departmentcontent> Milliken-Sarco-Tulocay Recycled Water Project

<http://www.countyofnapa.org/publicworks/FloodplainManagement/> Floodplain Management Permit Application

<http://www.mdrip.com/microsprinklers>

<http://www.ncdc.noaa.gov> National Climate Data Center

<http://www.picovale.com> Picovale Services Inc.

<http://www.precisionforecasting.com/Precision> Forecasting, LLC.

<http://www.rainbird.com>

<http://raindrip.com>

<http://www.shurfarms.com>

<http://www.terrapase.com>

[http://www.water.ca.gov/groundwater/data\\_and\\_monitoring/gw\\_level\\_monitoring.cfm](http://www.water.ca.gov/groundwater/data_and_monitoring/gw_level_monitoring.cfm). Last accessed September 8, 2009. Ca. Department of Water Resources. Groundwater Level Monitoring.

<http://www.weather.gov/asos.obs.htm> Automated Surface Observing System

<http://www.wrcc.dri.edu/coopmap> Western Coop Weather Stations

<http://www.weather.gov/oh/hads/> National Weather Service Hydrometeorological Automated Data System

<http://www.wxqa.com> Citizen Weather Observer Program

**Appendix 1**

**Frost Water Conservation Calculator**

**Frost Water Conservation Calculator**

Table 1 Inventory of Vineyards and Total Water Demand without BMPs

Vineyard area	Acres subject to frost	List subregion and total average hours of frost per crop year	Acres with sprinklers, list type	Acres in frost zone without sprinklers or wind machines	Acres in frost zone with wind machines	Total demand for acres with frost control	Total demand for acres without frost control	Total potential water demand in acre-feet for average season for site

Table 2 Evaluation/documentation of BMPs for site

Vineyard area	Acres subject to frost	Acres in frost zone without sprinklers or wind machines	Acres using wastewater/recycled water for frost control. List acres	Acres with early season budbreak and sprinklers, list current type of sprinkler	Acres with mid-season budding variety and sprinklers, list current type of sprinkler	Acres with late budding variety and sprinklers, list current type of sprinkler	Acres of mid season and late season varieties to be valved off	Current number of temperature monitoring sites, proposed new sites, and new acres covered	Is sprinkler type change is possible? List new sprinkler type and acres of replacement for each bud-break season	Have older overhead sprinklers, will replace with new ones? List acres of replacement for each bud-break season	On-site re-collection of water is feasible? List acres	Non-water frost control measures such as wind machines possible? List method and acres	List passive measures used and acres affected	List passive measures used and acres

Table 3 Calculating potential water savings for each BMP applied

Vineyard area	Acres subject to frost	Acres in frost zone without sprinklers or wind machines	Potential savings from not having frost protection on a portion of the vineyard	Potential water savings from installation of valves in water system	Potential savings from improved weather data to change on and off times	Potential water savings from installation of new overhead sprinklers to replace older ones, assumes 10% less water use per acre per hour, list acres of replacement	Potential water savings from installation of valves in water system.	Potential water savings from changing sprinkler type from standard to low flow, micro-, or pulsating micro-sprinkler	Potential water savings from installation of new overhead sprinklers to replace older ones	Potential savings by switching from water use to non-water use such as wind machines	Potential water savings from use of passive frost control measures	Total potential water savings in gallons per average season for site	Total potential water savings in acre-feet per average season for site

Subtotal of water demand for acres with early season budbreak for total average season	Subtotal of water demand for acres with mid season budbreak for total average season	Subtotal of water demand for acres with later season budbreak for total average season
1.0 of season	0.66 of season	0.33 of season
savings = 0	savings = 1.0-0.66 = 0.34	savings = 1.0-0.33= 0.67

Table 4 Determining Cost of each BMP applied

Vineyard area	Acres subject to frost (total )	Acres where water is used for frost	Cost of implementing passive measures	Cost of improved weather data to change on and off times	Cost of installing valves in water supply system	Cost of replacing or changing sprinklers	Cost for use of non-water frost control measures (wind machines)	Total cost	Cost per ac-ft of water savings
---------------	---------------------------------	-------------------------------------	---------------------------------------	--	--	--	--	------------	---------------------------------

**Prices used to determine costs**

Passive Measures	Temperature Monitors	Valve with Installation	Change Sprinklers	Wind Machines
double or late pruning \$150/acre	Uses number of new monitoring sites listed in Table 2	2" valve @ \$400	price of equipment and labor/acre	\$25-\$50,000/ wind machine, one machine per 6-9 acres
disk & roll vineyard \$150/acre	\$150 per digital thermometer	4" valve @ \$800	replace old overheads: \$475	
copper frost guard \$50/acre	\$1550 per cell phone connected to weather station	6" valve @ \$1200	micro sprinklers: \$4250	
additional mowing \$150/acre	\$6000/full range weather station	8" valve @ \$3000	low flow sprinklers: \$3000	
none and other \$0/acre	employee, \$150/5hrs frost monitoring for 200 acres	10" valve @ \$4000		
		12" valve @ \$5000		
		Add cost of pump replacement/retrofit if needed		

Table 5 Determination of water sources and potential for instream flow effects

Vineyard area	Acres subject to frost (total )	Total potential water demand in gallons per average season for site	List BMPs from Table 2 which you are applying or will be applying	List total water savings through BMPs in gallons average season for site	List % conservation savings with BMPs selected	List water source for each vineyard area	List method of diversion if applicable	List water demand using direct diversions from creeks	List Creek/River used for direct diversion



**PROTECTING INSTREAM FLOWS IN THE NAPA RIVER WATERSHED:  
TASK 3: PILOT STUDIES**

**INTRODUCTION**

Northern California wine country stretches from Mendocino and Lake Counties on the north to the Napa River and Sonoma Creek Valleys adjacent to San Francisco Bay. This region also supports three federally-listed threatened or endangered species – Chinook salmon, Coho salmon and steelhead trout. Irrigation water volumes used in wine grape vineyards are low, typically less than 0.7-0.5 acre feet (ac. ft.)/acre/year. High quality wines often use grapes grown using deficit irrigation, a technique which intentionally places the vine under water stress. In California’s Mediterranean climate, where the dry season coincides with the irrigation period, wine grapes are a low water use crop.

For parts of this winegrowing region, water is also used to protect new spring growth from freezing temperatures. Clear spring nights with dry weather can drop temperatures to freezing and the new buds on the grapevines can be burned and the entire crop lost. Some years, the number of frost nights is low. But a dry cold spring can bring numerous nights of frost and the need for frost control.

Frost control was done using smudge pots before electrical pumps and water systems were widely available. The smudge pots left smoke and air pollution in agricultural valleys and their use was restricted in the 1970’s. The replacement method developed was the application of water using sprinklers. The basic concept of frost control using water was developed by the University of California Extension Service and has allowed for the modern wine industry to expand to many locations. In Northern California, frost is only a concern following bud break, from about March 15 – May 15.

During a freeze, water is continually applied to the new growth on the vines. The volume of water used is high – up to 3,000 gallons/hour/acre, using standard overhead sprinklers. If frost events coincide with low rainfall and low stream flow, there is a potential for effects on salmonids.

The California Land Stewardship Institute (CLSI) is a non-profit organization that operates the Fish Friendly Farming Environmental Certification Program in Napa, Sonoma, Mendocino, and Solano Counties. The FFF certification is a comprehensive review of all aspects of an agricultural property which affect water quality, water flow and fish and riparian habitat. Both vineyards and wildlands are included in the review. CLSI works with the grower to produce a comprehensive Farm Conservation Plan. The plan is then certified by three regulatory agencies – National Marine Fisheries Service, Regional Water Quality Control Board and County Agricultural Commissioner. An FFF certification provides compliance under the Napa River and Sonoma Creek fine sediment TMDLs.

In addition to addressing fine sediment, the FFF program addresses stream flow, water sources and water rights on each property.

This project, funded by the Environmental Protection Agency (EPA) through a grant to the San Francisco Bay Estuary Partnership and the California Land Stewardship Institute, focuses on the Napa River Watershed, a major tributary to San Pablo Bay, which supports steelhead trout and Chinook salmon.

This report summarizes the results of the following task:

### **“Task 3 Identify Pilot Study**

This task involved identifying locations and methods for a pilot study to assess the feasibility of specific alternative frost control methods.”

## **BACKGROUND**

In the review of frost control practices in the Napa River Watershed completed for Task 2, CLSI has documented a series of water conservation practices and the approximate amounts of water conserved for the cost of the practice. One conservation practice that was identified that could provide significant water savings is the recollection of applied frost water using subsurface collection or drainage systems. There have not been any studies of the efficiency of this practice. As part of Task 2, CLSI documented the factors which influence implementation of alternative frost control measures. As part of this analysis, we identified a need for stream flow monitoring by growers to determine potential effects on salmonid habitats and the need for coordination of diversions between growers. Both of these needs are discussed here as pilot studies.

## **PILOT STUDY 1**

### **Subsurface Drainage Systems**

Frost control with water is used in various locations in the Napa River watershed where springtime freezing temperatures are too low for wind machines to be effective. Water is applied with overhead sprinklers at a rate of 50 gallons/minute from the time that the wet bulb temperature reaches 32°F until the morning temperatures exceed that level in the vineyard. When water is applied, it coats the vines and the cover crop and ancillary areas infiltrating into the soil. Water applications cannot be reduced or stopped until temperatures rise or vegetation will be burned. As this water is applied, it continuously changes from a liquid to a solid state on the vine and also evaporates and infiltrates into the soil. Once temperatures rise, the ice melts and the water infiltrates or evaporates.

For periods with numerous nights of frost, the availability of water may become a problem in some areas. Recollection of applied water using subsurface drainage systems may provide for an efficient measure to conserve water. However, the cost to install these systems is high so the efficiency and cost effectiveness need to be documented.

Agricultural lands are often drained in order to dry out soils and allow crops to grow. The type of drainage facilities used has varied over time and with locations. In the Napa River Watershed, subsurface drainage is commonly installed on the valley floor or other low-lying areas where high groundwater levels or ponding can reduce crop viability. Subsurface drainage systems typically consist of perforated plastic pipe set in trenches 24-30 inches below the surface of the vineyard. A grid of pipes may feed into an outlet pipe which drains to a ditch or creek or may feed into a sump. Sumps are usually a vertical corrugated metal pipe where the drainage water collects. A pump may be used to move the water from the sump to an off-channel reservoir or to a creek or ditch (Figure 1). Natural Resource Conservation Service specifications for these systems are included in Appendix 1.

The perforated pipe network is typically installed to intercept shallow groundwater where it ponds on a vineyard site. Typically, the pipes are not installed throughout the vineyard if the purpose of the system is drainage.

Figure 1 Components of Subsurface Collection System

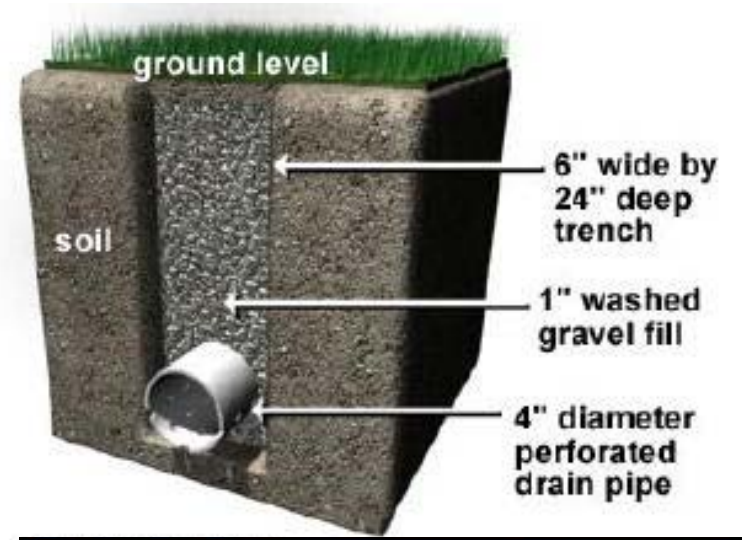
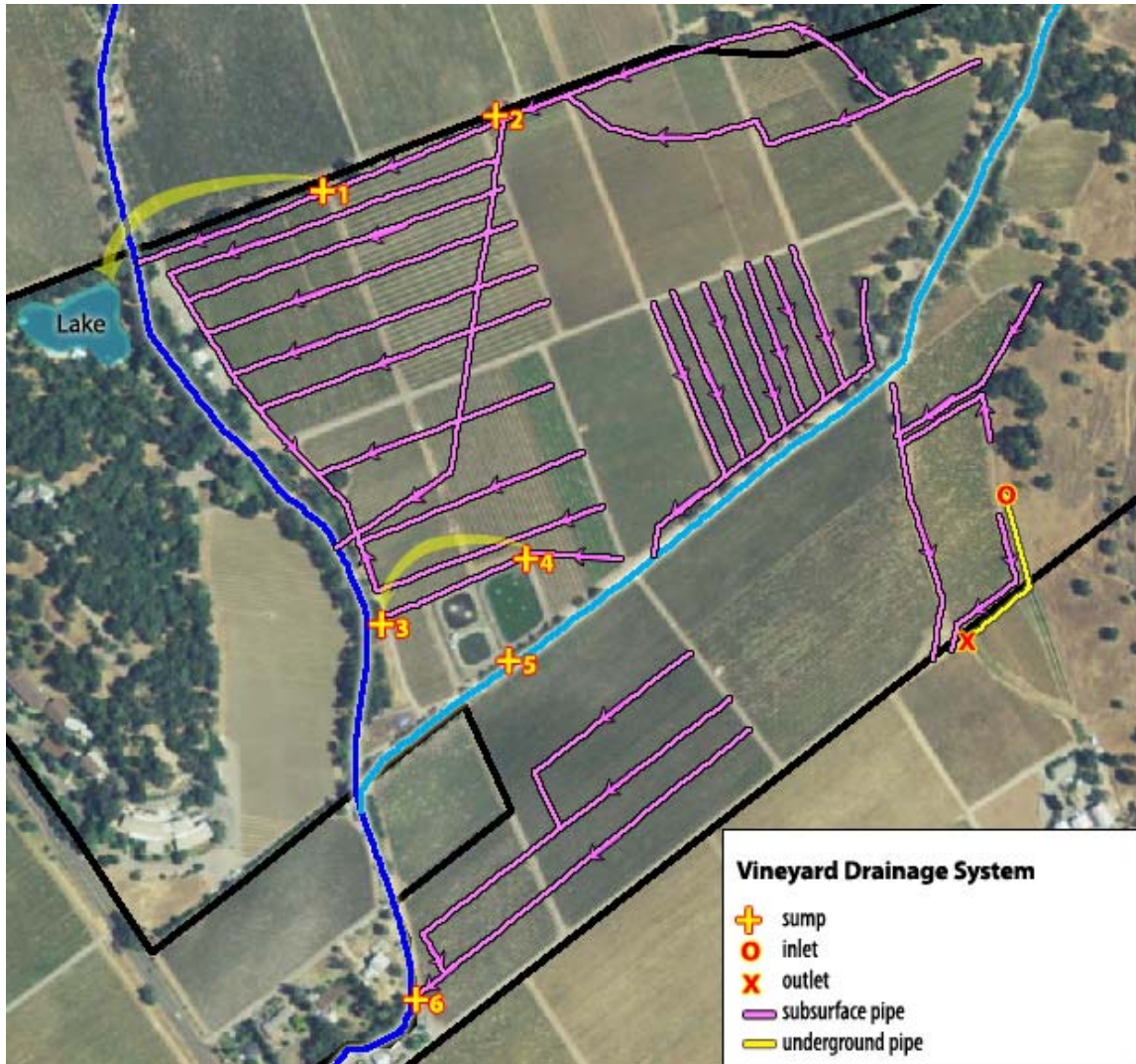

Sump

In some areas, perforated pipe is installed over a wide area of the vineyard to collect subsurface water as a source for frost control and irrigation. If no surface water is mixed in with the subsurface water, then this system can be used to provide a water supply without undergoing an appropriate water right permit.

Pilot study #1 would use vineyards with a large subsurface collection system to evaluate if recollecting applied frost water is effective enough to warrant installation in additional sites as a water conservation measure.

The function and efficiency of subsurface drainage will largely depend upon soil type and the speed of water infiltration. It is our belief that sites with well drained soil types will be less efficient and cost-effective for recollecting frost water and require very dense networks of subsurface pipe. Sites with moderate to slow drainage will allow adequate time for the recollecting system to work without needing an expensive dense network.

We reviewed the soil types in the Napa River watershed on the valley floor where subsurface drainage systems are most common. Table 1 lists the soil series in the Napa County Soil Survey and the hydrologic soil group. Soils in groups C & D were considered as highest priority for the pilot study locations.

We compared the locations of soils in the C & D hydrologic soil group with the locations of Fish Friendly Farming sites. Figure 2 depicts sites in the program in frost prone areas with soils in hydrologic soil groups C & D. We then evaluated these sites and discussed the Pilot Study #1 with landowners/managers to determine their willingness to participate. We found a number of willing cooperators whose primary concern is the capital cost of installing any improvements needed for Pilot Study #1. We assured the owners/managers that CLSI would seek funding for capital improvement costs.

**Table 1 Napa County Soil Types**

Soil Series	Map Unit Number	Permeability	Hydrologic Soil Group*
Aiken	100-102	Moderately slow	B
Bale	103-106	Moderate	C
Boomer	107-111	Moderately slow	B
Bressa	112-115	Moderately slow	C
Clear Lake	116, 117	Slow to very slow	D
Cole	118, 119	Moderately slow	C
Contra Costa	120-121	Slow	C
Coombs	122, 123	Moderately slow	B
Cortina	124, 125	Rapid	A
Diablo	126-129	Slow	D
Egbert	130	Slow	D
Fagan	131-134	Slow	C
Felton	135-137	Moderately slow	C
Forward	138-141	Moderately rapid	C
Guenoc	142-144	Moderately slow	C
Haire	145-150	Very slow	C
Hambright	151, 152	Moderate	D
Henneke	153, 154	Moderately slow	D
Kidd	155, 156	Moderately rapid	D
Lodo	157	Moderate	D
Los Gatos	158-160	Moderately slow	C
Maxwell	161	Very slow	D
Maymen	162, 163	Moderate	D
Milsholm	164, 165	Moderate	D
Montara	166, 167	Moderately slow	D
Perkins	168, 169	Slow	C
Pleasanton	170, 171	Moderately slow	B
Reyes	172, 173	Slow	D
Sobrante	178, 179	Moderate	C
Tehama	180	Slow	C
Yolo	181, 182	Moderate	B

\*Hydrologic soil groups are used to estimate runoff from precipitation. Soils not protected by vegetation are placed in one of four groups on the basis of the intake of water after the soils have been wetted and have received precipitation from long-duration storms.

The four hydrologic soil groups are:

**Group A.** Soils having a high infiltration rate (low runoff potential) when thoroughly wet. These consist chiefly of deep, well drained to excessively drained sands or gravels. These soils have a high rate of water transmission.

**Group B.** Soils having a moderate infiltration rate when thoroughly wet. These consist chiefly of moderately deep to deep, moderately well drained to well drained soils that have moderately fine texture to moderately coarse texture. These soils have a moderate rate of water transmission.

**Group C.** Soils having a slow infiltration rate when thoroughly wet. These consist chiefly of soils that have soil. See mapping unit description for the composition and behavior of a layer that impedes the downward movement of water or soils that have moderately fine texture or fine texture. These soils have a slow rate of water transmission.

**Group D.** Soils having a very slow infiltration rate (high runoff potential) when thoroughly wet. These consist chiefly of clay soils that have a high shrinkswell potential, soils that have a permanent high water table, soils that have a claypan or clay layer at or near the surface, and soils that are shallow over nearly impervious material. These soils have a very slow rate of water transmission.

### **Study Design**

The Pilot Study #1 will require the following steps:

1. Map existing subsurface drainage systems on the selected sites including locations of perforated pipes, solid pipes, outlets, sumps, pumps and reservoirs. The sizes and capacity of each element will be documented along with the age and overall condition and level of function.
2. Determine locations for monitoring devices such as flow meters, soil moisture sensors and water level dataloggers.
3. Determine the average number of hours of frost and water volumes applied.
4. Evaluate the slope of the site and likely direction of subsurface water movement.
5. Determine if existing system of subsurface pipes represents the most effective layout for recollection of subsurface water and, if not, what changes are needed. These changes could include installation of additional subsurface pipe, relocation or enlargement of sumps/pumps or, for sites with subsurface drainage only, installation of sumps and pipe to reservoirs or another storage facility.

There needs to be a balance between the cost of installing these systems and their usefulness in recovering water. So we will use the specifications of the NRCS to guide the needed features of the system (Appendix 1).

The focus of the data collection/evaluation phase will be to measure:

1. **Hours of frost and volume of water applications.** These will be documented by temperature/weather station records and in-line flow meters on the frost water mainline.
2. **Soil moisture.** As water is applied to the vines, it will drip off the vegetation and infiltrate into the soil. Soil moisture sensors set at a series of depths ranging from 12 inches to 48 inches can record the rate at which water moves through the soil and reaches the depth of the subsurface collection system. There are many factors which will affect this process including soil type, water year (critically dry, dry, normal, or wet), level of the groundwater table, slope and location of site. Understanding this process will allow for the sump pump to be turned on at the most effective time for the recollection process.
3. **Metering at sump or reservoir.** To test the efficiency of the recollection of water in-line flow meters at the sump or reservoir inflow will be needed. These will measure the volume of water moved from the sump to storage and therefore the total recollected volume.
4. **Other records.** Rainfall and stream flow records will be collected to characterize conditions each year. It is possible to have frost in wet years and when groundwater levels are high as well as in very dry years.

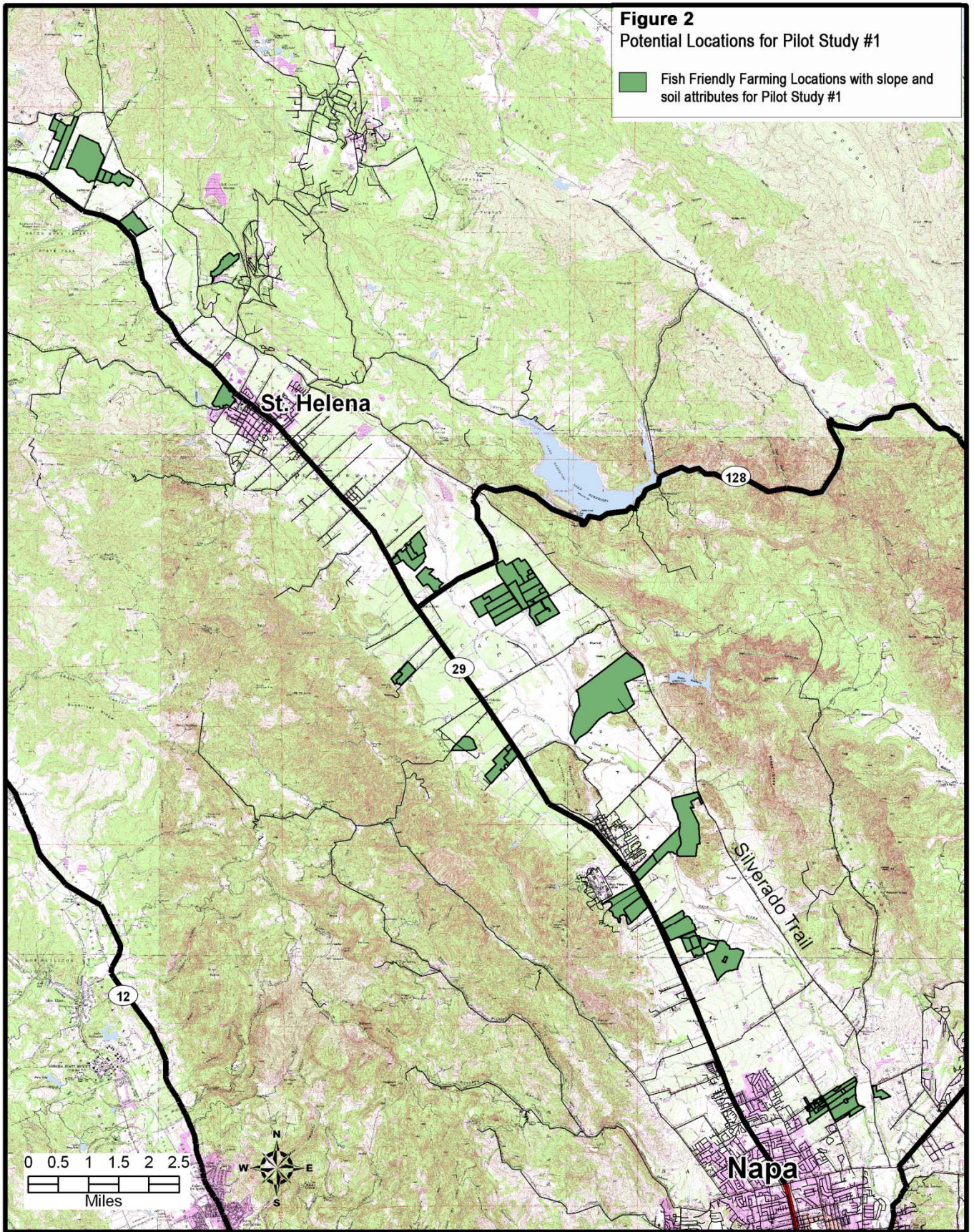

5. **Time and Extent.** Because of the level of physical variability between sites and years, a number of vineyards will need to be included in Pilot Study #1 and the study will need to extend over at least a 5-year period. We recommend that sites on both the wetter west side of the valley and the dry east side of the valley be included and that an emphasis be placed on low-lying frost prone lands.
6. **Cost and Benefit Analysis.** The cost per acre foot of water recollected would be determined. Costs for an entire system installation and for retrofitting existing systems would be developed. This practical application and analysis of this management measure will determine if implementation is warranted by many growers.

CLSI will work with UC Cooperative Extension and the NRCS to further develop and implement Pilot Study #1 as the results of the study provide useful information for a potential water saving BMP which these two agencies along with CLSI can recommend to growers.



## **PILOT STUDY 2**

### **Coordinating Diversions**

There are several challenges to creating a system of coordinated diversion between various landowners in a tributary basin. Pilot Study #2 requires stream flow monitoring, evaluation of fish habitats, determination of needed stream flow levels and a determination if coordination is needed to achieve these stream flow levels.

### **Background**

In the Napa River Watershed, water rights and water supply facilities are developed on individual farms and properties. There is no centralized irrigation district and few shared facilities. Water supply facilities include on-stream reservoirs, off-stream reservoirs, deep and shallow groundwater wells, recycled water, direct diversions, and subsurface collection systems with off-stream reservoirs. The operation of each individual system is governed by the conditions in the appropriative water right permit and the need for irrigation and/or frost control. Typical conditions in water right permits are the allowable season of diversion, point of diversion, the volume or rate of the allowed diversion and the flow level in a creek or river which must be met or exceeded before diversions are allowed. Some permits may require the bypass of a certain volume of flow during the diversion. Water right permits vary greatly in the conditions required. Additionally, water rights permits only apply to surface water diversions and storage but not to groundwater use and riparian or direct diversions.

The types and locations of water supply facilities and individual site needs for water coupled with geology, topography, and rainfall create a different situation in every tributary basin. Therefore, to coordinate diversions and protect instream flows, the most effective approach is to outline a methodology for growers to use and apply it to one to several tributaries as a pilot study.

Pilot Study #2 will focus on building the capacity in the grower community to integrate stream flow monitoring, coordinating diversions, and protection of instream flows for fish into agricultural operations rather than relying on outside experts or regulation. This study would set up demonstration projects with growers on tributary streams. This approach will integrate environmental protections into agricultural operations.

### **Project Methods**

#### **Tributary Watershed Analyses**

Pilot Study #2 will start by evaluating tributary watersheds in the Napa River basin in order to choose two sub-basins for monitoring. CLSI will use a Geographic Information System (GIS) database in ArcView and digital data layers for slope, geology, soils, ownership, vineyards, water rights, stream network, and salmonid occurrence to create an information matrix. These data layers will be collected primarily from government sources. The analyses will be used to identify sub-basins which provide the best opportunity for monitoring and coordination of diversions and demonstration of these methods to growers.

### **Grower Outreach and Involvement**

CLSI will maximize grower involvement and training through both the Fish Friendly Farming Program and coordination with grower organizations.

### **Evaluation of Water Facilities**

As part of the identification of tributaries for diversion coordination, water rights and water supply facilities will be reviewed. Figure 3 and Table 2 show the appropriative water rights in tributary basins. Through meetings with growers, we will determine all of the types of surface water diversions and storage facilities along with timing, volume and rate of each diversion. Wells will also be inventoried.

### **Hydrologic Monitoring**

The project will use the US Geologic Survey's protocols for stream flow gaging. This protocol defines the appropriate locations for gaging stations and restrictions based on channel type, form, and location; instrument selection and installation; methods for measuring stream stage; measuring of discharge using a current meter; and the creation of a rating curve for the station. Pressure transducers will be used to record stage and instruments with a high level of accuracy at the low flow level will be used. Data will be collected at 30 minute intervals. The number and location of gages will be evaluated with the location and types of diversions to assure that diversion coordination can be implemented.

A stream flow gage will be installed at a downstream location to define the target stage needed for minimum instream flows. Depending on the tributary, subsurface water depths may also need to be monitored. Piezometers will be installed at either existing wells or monitoring wells at staggered locations in the alluvial area and data loggers deployed to record water levels.

### **Topographic Survey**

The relative elevations of all of the surface and subsurface monitoring stations will need to be established by topographic survey. The survey will also establish the elevations of critical areas of fish habitat in the creek. These areas would include spawning riffles and rearing pool habitats as well as any potential barriers to out-migration. These areas will be evaluated by a fisheries biologist and determinations made of minimum and optimal flow levels for habitat functions. Using a topographic survey, these stream flow levels will then be established and defined by stage at the downstream flow gage and will become the minimum instream flow target. The topographic survey will be completed to an accuracy of 0.1 ft. and will be tied to established benchmarks of known elevation.

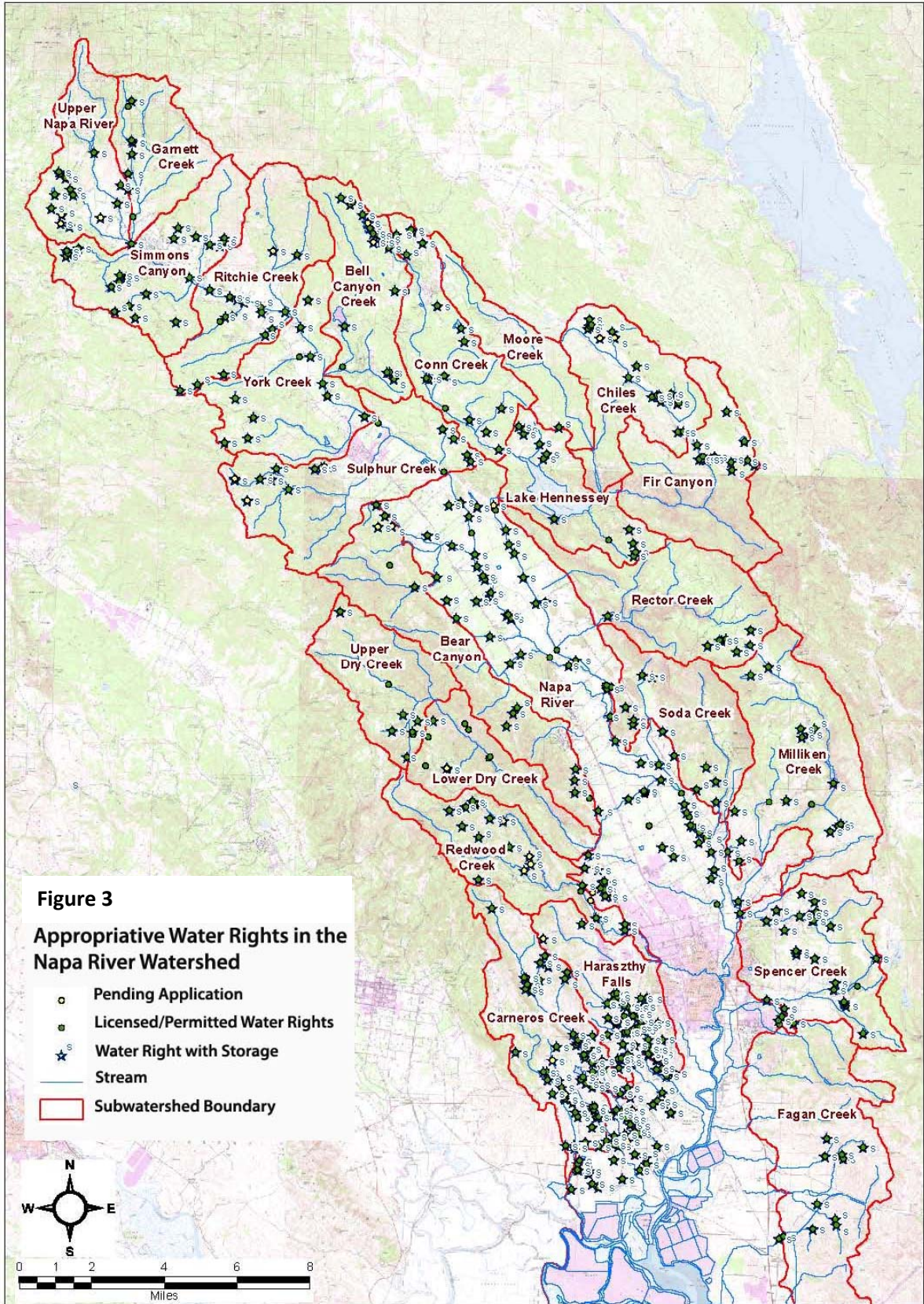

Sources: eWRIMS database from SWRCB, April 4, 2008; USGS Topographic quadrangles

L:\MapKey 611\CLSL 3/1/2010

**Table 2. Appropriative Water Rights in the Napa River Watershed for Agricultural and Municipal Uses**

	<b>Subwatershed</b>	<b>Number of Appropriate Water Rights</b>	<b>Face Value of Water Right</b>	<b>Acres of Subwatershed</b>
571	Upper Napa River	14	1851.5	6,177
	Licensed	11	942.8	
	Pending	2	51.7	
	Permitted	1	857	
575	Garnett Creek	7	101.8	5,088
	Licensed	6	73.8	
	Permitted	1	28	
592	Simmons Canyon	19	245.4	8,553
	Licensed	16	175.4	
	Permitted	3	70	
595	Ritchie Creek	16	447.5	8,768
	Licensed	11	275.5	
	Pending	1	15	
	Permitted	4	157	
599	Bell Canyon Reservoir	35	5973.4	6,830
	Licensed	22	827.9	
	Pending	2	205	
	Permitted	11	4940.5	
605	Conn Creek	15	766.1	7,297
	Licensed	9	270.1	
	Permitted	6	496	
607	Moore Creek	1	1.3	4,819
	Licensed	1	1.3	
611	York Creek	15	231.4	8,444
	Licensed	14	182.4	
	Permitted	1	49	
616	Chiles Creek	13	441.5	7,293

**Table 2. Appropriative Water Rights in the Napa River Watershed for Agricultural and Municipal Uses**

	<b>Subwatershed</b>	<b>Number of Appropriate Water Rights</b>	<b>Face Value of Water Right</b>	<b>Acres of Subwatershed</b>
	Licensed	10	322.5	
	Pending	2	98	
	Permitted	1	21	
624	Fir Canyon	14	683	8,195
	Licensed	2	110	
	Permitted	12	573	
627	Heath Canyon	15	521.3	10,141
	Licensed	8	258.3	
	Pending	2	70	
	Permitted	5	193	
632	Lake Hennessey	16	43553.6	5,761
	Licensed	8	140.7	
	Permitted	8	43412.9	
642	Napa River	131	9648.1	82,199
	Licensed	82	3078.5	
	Pending	7	204	
	Permitted	42	6365.6	
643	Rector Reservation	8	4679	9,325
	Licensed	3	3554	
	Permitted	5	1125	
644	Bear Canyon	12	1913.2	9,377
	Licensed	5	54.9	
	Pending	1	52	
	Permitted	6	1806.3	
654	Upper Dry Creek	8	77.6	6,107
	Licensed	7	47.6	
	Permitted	1	30	
656	Milliken Reservoir	22	6098.1	12,439
	Licensed	16	2641.1	

**Table 2. Appropriative Water Rights in the Napa River Watershed for Agricultural and Municipal Uses**

	<b>Subwatershed</b>	<b>Number of Appropriate Water Rights</b>	<b>Face Value of Water Right</b>	<b>Acres of Subwatershed</b>
	Permitted	6	3457	
658	Soda Creek	9	187.8	7,070
	Licensed	7	108.8	
	Permitted	2	79	
665	Lower Dry Creek	7	59	5,679
	Licensed	5	14	
	Pending	1	15	
	Permitted	1	30	
669	Redwood Creek	18	355.7	6,975
	Licensed	9	150.7	
	Pending	3	79	
	Permitted	6	126	
679	Spencer Creek	28	723.7	9,035
	Licensed	25	479.7	
	Permitted	3	244	
680	Carneros Creek	49	2184	9,577
	Licensed	19	657	
	Pending	2	72	
	Permitted	28	1455	
683	Haraszthy Falls	46	1281.2	6,068
	Licensed	24	399	
	Pending	1	9.7	
	Permitted	21	872.5	
691	Fagan Creek	9	295.9	18,698
	Licensed	5	73.9	
	Permitted	4	222	
	<b>Grand Total</b>	527	82321.1	82199.2

### **Coordinating Diversions and Maintaining Instream Flow**

All of the data from the surface water gages and subsurface water level gages will need to be analyzed with records of diversion rates and times. Depending on the type of water supply facility, an inline flow meter or other method will be used to provide accurate records at 15-30 minute intervals. The GPS coordinates and elevation of each gaging station, subsurface monitor and diversion will be recorded. The stream channel dimensions of width, length, roughness, and bed composition will also be surveyed. For each stream reach, some assumptions regarding the movement of surface flow to groundwater and groundwater to surface flow and the seasonality and magnitude of this movement will be made and refined over time.

Once this network is established, a series of trials will be carried out in coordinating diversions, reducing diversions, etc. and the results analyzed. The results will be evaluated with growers and additional changes to diversion rates and timing will be discussed. Because many of these tributary streams have complex geology and variable topographic and hydrologic features, this trial analysis provides a broadly applicable methodology.

Depending on the water facilities, some infrastructure changes may be needed to allow for coordination of diversions. For example, direct diversions for frost cannot be altered in their use unless storage is available.

### **Applying Water Facility BMPs**

To reduce the cumulative effects of surface and groundwater use for frost control additional changes may be needed to water facilities. These were discussed in the Task 2 report and are included here.

### **Deep and Shallow Wells**

Each well draws water from the groundwater basin around it. Determining the precise effect of a shallow well on stream flow can be complex and difficult if the well is in an alluvial valley and not near a stream channel. The effects on stream flow of pumping groundwater from deep wells can also be difficult to determine. Only shallow wells which are immediately adjacent to a stream channel may show an obvious effect on stream flow. Further complicating evaluations of the effects of individual wells on stream flow is that the number of wells operating simultaneously in an alluvial basin may have a larger effect than staggered use of individual wells. Determining the effect of an individual well separate from other wells may be impossible.

Given this level of uncertainty, it may be more valuable to change wells near streams rather than attempt to prove a lack of effects. There are ways to change the depth at which water is drawn and thereby reduce the potential for effects on stream flow. This is done by changing the casing or liner on the well to block the screens or perforations in the top 30-50 ft. of the well. By moving the location of where water is withdrawn to a deeper area, the instantaneous effect on the stream can be reduced. Reducing the size of the pump and withdrawing water at a slower rate (lower well production) can also reduce the instantaneous effects on stream flow.

### **On-stream Reservoirs**

Individual on-stream reservoirs can be evaluated for their effects on downstream flow. As part of the monitoring, a flow gage can be established in the tributary creek just downstream of the reservoir location. Using this gage can be used to determine whether the on-stream reservoir fills and spills before or after the alluvial reach has continuous flow and what rainfall amounts affect the onset of

continuous flow. This type of analysis for a water facility will determine when stream habitats have continuous flow and are available to salmonids and whether the on-stream reservoir has a major effect on the timing of continuous flow conditions downstream. If the reservoir typically fills and spills before continuous flow conditions are reached, other limiting factors have a greater influence than the reservoir. In tributaries with large numbers of on-stream reservoirs, the cumulative effect of the fill and spill operations on both the timing and magnitude (stage) of stream flow also needs to be evaluated.

If the monitoring shows the reservoir does affect the timing of continuous flow, it can be retrofitted with a bypass pipe or channel. Then the reservoir can be operated to release the water that flows into it in the early part of the rainy season. Then later into the rainy season, the bypass can be closed and the reservoir allowed to fill and spill. The monitoring can be used to determine the level of rainfall needed before the reservoir bypass can be closed and the reservoir can be allowed to fill.

**Off-stream Reservoirs** - Off-stream reservoirs should be located out of the floodway of the river and creeks to avoid changing the direction of flood water. There are several different water sources which could be used to fill and off-stream reservoir including:

**Direct diversions** used to fill off-stream ponds can be operated to take a low amount of flow during daylight hours when no large volume diversions for frost control are occurring. The timing and magnitude of the direct diversion should also be limited by the stream flow level at the diversion site and not lower the stage significantly. A stream flow gage at the diversion site can be used to fine tune the timing and volume of diversions to avoid lowering the stream flow below the predetermined stage relevant to fish habitats.

If a **well** has a low production rate, an off-stream storage reservoir can provide the volume of water needed for frost control.

The operation of **subsurface collection systems** may affect the timing and magnitude of stream flow in nearby creeks in very dry years. Operations can be changed to bypass flow collected in sumps until after several major storms have passed and nearby creeks have continuous flow. For systems of this type located on the valley floor, they are unlikely to affect groundwater levels or stream flow in the Napa River as the majority of recharge to the valley groundwater basin comes from runoff from the adjoining mountains.

### **Direct Diversions**

For those sites where direct diversions provide water directly into the frost system, there are few measures that can be implemented to reduce diversion volumes. An off-stream storage pond or well has to be used to increase flexibility in managing the timing and volume of the diversion.

## **HUMAN INFRASTRUCTURE**

Another part of having groups of growers manage water diversions to protect instream flows is to create organizations to support these actions. There are several options:

### **Irrigation District**

An irrigation or agricultural water district is a special district created through an Act of the California Legislature to supply water for defined purposes. It would be impractical to create irrigation districts for



each tributary basin in the Napa River drainage. However, one watershed-wide district could provide an umbrella for all agricultural water users. How the district interacts with the numerous separate water rights holders would need to be determined and defined in the districts enabling legislation.

### **Mutual Benefit Corporation**

Mutual benefit corporations can be formed for a number of purposes including homeowner associations, clubs, and water user associations. Mutual benefit associations are incorporated and their articles of incorporation define their purposes. A Board of Directors forms and prepares bylaws which direct the actions of the corporation. Since it is relatively easy to form a mutual benefit corporation, one could be created for each tributary and provide a formal organization for landowners/manager to work together.

### **Mutual Water Company**

Mutual Water Companies are private corporations or associations organized for the purposes of delivering water to its stockholders or members at cost including water conservation and water recycling. Mutual water companies can issue stock to its members coincident with the priority and size of water rights in the tributary basin and can be small or large. This type of organization may be a good fit to the need for landowners/managers to coordinate water use in a tributary basin.

### **Stewardship or Watershed Group**

An informal organization of growers could be formed to coordinate water management and complete monitoring.

### **SUMMARY**

Following a thorough review of the use of water for frost control, water conservation measures and water rights issues, CLSI identified two pilot studies to address critical questions. Pilot Study #1 would evaluate the efficiency of subsurface water recollection systems and the cost effectiveness for growers to install these systems. Pilot Study #2 addresses the need for stream flow monitoring and coordinated diversions between owners/managers in tributary basins to assure adequate instream flow levels for fish.

# Task 4 Quality Assurance Project Plan

For the

## Stream Flow Monitoring and Coordinated Diversions Pilot Study

Revision 1, October 20, 2011

(Original June 15, 2011)

### California Land Stewardship Institute

550 Gateway Drive, #108, Napa, CA 94558

#### APPROVAL SIGNATURES

Title:	Name:	Signature:	Date:
Project Manager	Laurel Marcus	_____	_____
QA Officer	_____	_____	_____
Staff Specialist	_____	_____	_____
Land Manager	_____	_____	_____

#### DISTRIBUTION LIST

Name, Affiliation	Phone	Email
Laurel Marcus, CLSI	707-253-1226	laurelm@fishfriendlyfarming.org
_____	_____	_____
_____	_____	_____
_____	_____	_____



UNITED STATES ENVIRONMENTAL PROTECTION AGENCY  
REGION 9  
75 Hawthorne Street  
San Francisco, CA 94105

November 22, 2011

MEMORANDUM

SUBJECT: Approval of the quality assurance project plan, "Stream Flow Monitoring Pilot Study, Revision 1" California Land Stewardship Institute, November 16, 2011. EPA document control number: WATR0779QV2.

FROM: Rich Freitas, Environmental Scientist *RF*  
Quality Assurance Office, MTS-3

THROUGH: Eugenia McNaughton, Manager *Eugenia McNaughton*  
Quality Assurance Office, MTS-3

TO: Erica Yelensky, Project Officer, *EY*  
Watersheds Office, WTR-3

The concerns presented in the September 6, 2011 QA office review memo have been satisfactorily addressed in the revised document. The plan is approved. Attached is a copy of the signature page.

The review was based on the guidance provided in "EPA Requirements for Quality Assurance Project Plans," (EPA QA/R-5, EPA/240/B-01/003, March, 2001), and the "Wetlands Quality Assurance Project Plan Guidance, Version 1.0," (USEPA Region 9, September 30, 2004).

## **SECTION 1.0 PROJECT DESCRIPTION AND OBJECTIVES**

The Stream Flow Monitoring and Coordinated Diversions Pilot Study encourages growers to integrate stream flow monitoring into agricultural operations. Stream flow data will contribute to a fact-based assessment of the variation in water availability and whether diversions need to be coordinated in a particular tributary to assure adequate instream flow levels for fish.

Following a thorough review of water use for frost control, water conservation measures, and water rights issues, California Land Stewardship Institute (CLSI) identified two pilot studies to address critical questions. The second pilot study—the Stream Flow and Coordinated Diversion Pilot Study, which this QAPP is for—requires stream flow monitoring, evaluation of fish habitats, determination of needed stream flow levels, and a determination if diversions need to be coordinated between owners/ managers in tributary basins to achieve these stream flow levels.

Currently there are no stream flow data available in tributary basins of the Napa River watershed to demonstrate deleterious effects of frost control on stream flow or to inform decisions about restricting water use for fish habitat needs at critical times. By collecting stream flow data at selected stations and generating reliable rating curves, water level measurements can be used to calculate discharge at those selected sites. The discharge or flow data can then be assessed to determine if the level of flow requires landowners to coordinate their withdrawals to avoid a critical draw-down of the water level that would endanger fish. There is no pre-determined required flow level; it will be specific to each tributary basin and depend on the fish in that tributary as established by the topographic survey and the fisheries biologist (see 1.4, Topographic Survey).

### **1.1 Background**

In the Napa River Watershed, water rights and water supply facilities are developed on individual farms and properties. There is no centralized irrigation district and few shared facilities. Water supply facilities include on-stream reservoirs, off-stream reservoirs, deep and shallow groundwater wells, recycled water, direct diversions, and subsurface collection systems with off-stream reservoirs. The operation of each individual system is governed by the conditions in the appropriative water right permit and the need for irrigation and/or frost control. Typical conditions in water right permits are the allowable season of diversion, point of diversion, the volume or rate of the allowed diversion and the flow level in a creek or river which must be met or exceeded before diversions are allowed. Some permits may require the bypass of a certain volume of flow during the diversion. Water right permits vary greatly in the conditions required. Additionally, water rights permits only apply to surface water diversions and storage, but not to groundwater use and riparian or direct diversions.

The types and locations of water supply facilities and individual site needs for water coupled with geology, topography, and rainfall create a different situation in every tributary basin. Therefore, to coordinate diversions and protect instream flows, the most effective approach is to outline a methodology for growers to use and apply it to one to several tributaries as a pilot study

that will focus on building the capacity in the grower community to integrate stream flow monitoring, coordinating diversions, and protection of instream flows for fish into agricultural operations rather than relying on outside experts or regulation. This study would set up demonstration projects with growers on tributary streams. This approach will integrate environmental protections into agricultural operations.

## **1.2 Evaluation for Selection of Tributary Subwatersheds**

Using digital data in a Geographic Information System (GIS) database (ArcGIS10) to evaluate slope, geology, soils, ownership, vineyards, water rights, water supply facilities, stream networks, and salmonid occurrence in 23 tributary watersheds in the Napa River basin, CLSI will identify two sub-basins that provide the best opportunity for monitoring, coordination of diversions, and demonstration of these methods to growers.

Figure 1 and Table 1 show the appropriate water rights in 23 tributary basins, as well as the Napa River itself. Through meetings with growers, CLSI will determine all of the types of surface water diversions and storage facilities along with timing, volume, and rate of each diversion. Wells will also be inventoried.

## **1.3 Hydrologic Monitoring**

The project will use the US Geologic Survey's protocols for stream flow gaging, specified in the Stream Flow Monitoring Protocol, Appendix A. This protocol defines the appropriate locations for gaging stations and restrictions based on channel type, form, and location; instrument selection and installation; methods for measuring stream stage; measuring of discharge using a current meter; and the creation of a rating curve for the station. Pressure transducers will be used to record stage and instruments with a high level of accuracy at the low flow level will be used. Data will be collected at 30-minute intervals. The number and location of gages will be evaluated with the location and types of diversions to assure that diversion coordination can be implemented.

A stream flow gage will be installed at a downstream location to define the target stage needed for minimum instream flows. Depending on the tributary, subsurface water depths may also need to be monitored. Piezometers will be installed at either existing wells or monitoring wells at staggered locations in the alluvial area and data loggers deployed to record water levels.

## **1.4 Topographic Survey**

The relative elevations of all of the surface and subsurface monitoring stations will need to be established by topographic survey. The survey will also establish the elevations of critical areas of fish habitat in the creek. These areas would include spawning riffles and rearing pool habitats as well as any potential barriers to out-migration. These areas will be evaluated by a fisheries biologist and determinations made of minimum and optimal flow levels for habitat functions. Using a topographic survey, these stream flow levels will then be established and defined by stage at the downstream flow gage and will become the minimum instream flow target. The

topographic survey will be completed to an accuracy of 0.1 ft. and will be tied to established benchmarks of known elevation.

### **1.5 Coordinating Diversions and Maintaining Instream Flow**

All of the data from the surface water gages and subsurface water level gages will need to be analyzed with records of diversion rates and times. Depending on the type of water supply facility, an inline flow meter or other method will be used to provide accurate records at 15-30 minute intervals. The GPS coordinates and elevation of each gaging station, subsurface monitor, and diversion will be recorded.

The stream channel dimensions of width, length, roughness, and bed composition will also be surveyed. For each stream reach, some assumptions regarding the movement of surface flow to groundwater and groundwater to surface flow and the seasonality and magnitude of this movement will be made and refined over time.

Once this network is established, a series of trials will be carried out in coordinating diversions, reducing diversions, etc., and the results analyzed. The results will be evaluated with growers and additional changes to diversion rates and timing will be discussed. Because many of these tributary streams have complex geology and variable topographic and hydrologic features, this trial analysis provides a broadly applicable methodology.

Depending on the water facilities, some infrastructure changes may be needed to allow for coordination of diversions. For example, direct diversions for frost cannot be altered in their use unless storage is available.

[Applying water facility BMPs: deep and shallow wells, on-stream reservoirs, off-stream reservoirs, direct diversions, human infrastructure (irrigation district/mutual benefit corporation/mutual water company/; other pilot study: recycled frost water]

### **1.6 Duration and Scope**

The Stream Flow Monitoring and Coordinated Diversions Pilot Study is the initial phase of a long-term project. The pilot study is expected to take between five and seven years to collect data for rating curves to be sufficiently accurate. The area involved includes 23 tributaries of the Napa River shown in the Figure 1 map and listed in Table 1.

### **1.7 Constraints**

The most significant constraint to the development of high quality data sets for stream flow monitoring is the location of the monitoring stations. Poorly located stations will not measure all of the flow passing the station due to losses to groundwater, choice of a site with multiple channels or a very wide area of flow at higher flows, or selecting sites located in meanders of an alluvial channel. Data from poorly located stations has limited value. Another constraint is a lack of frequent checks and measurements to maintain the gage site and rating curve. Finally, it

should be recognized that several to many years of data and analysis are needed to produce datasets to characterize stream flow patterns.

### **1.8 Summary of the Stream Flow Monitoring Procedure**

A number of stream flow monitoring stations will be established in a tributary basin. A relationship between the water level (stage) and discharge at the site will be developed by taking discharge measurements over the expected range of flows. The discharge measurement and corresponding stage will be plotted to generate a stage-discharge rating curve for each gaging station. The rating curve will be used with a gage that records continuous water level to derive a discharge time series for the site, which will then be used to evaluate the site as a candidate for co-ordination of diversions.

#### **The Stream Flow Gaging Procedure**

1. Evaluate locations for the stream flow gaging station
2. Estimate the expected range of flow rate and flow depth at the chosen site to select the type of continuous water level recorder
3. Install a staff gage and a continuous water level recorder at each site
4. Survey the channel cross-section at the gaging station and relate it to known elevation points
5. Measure discharge at or near the gaging station for a range of flow levels
6. Generate a rating curve for the gaging station using the discharge and stage measurements
7. Maintain the data generated by the water level recorder, using the stage/discharge rating to produce time series stream flow data
8. Assess the data and operation of equipment, checking it against the stream gage

## **SECTION 2.0 PROJECT ORGANIZATION**

California Land Stewardship Institute (CLSI) is a nonprofit organization interested in the enhancement of riparian and aquatic habitat and improvement of water quality. CLSI will work with landowners in tributary basins to select the location, estimate the expected flow rate and depth ranges, install a staff gage and a continuously recording water level gage, survey a cross section at the monitoring site with a benchmark that is surveyed to points of known elevation, and measure discharge sufficient to generate a rating curve. CLSI will consolidate the data from each site and review for accuracy and representativeness.

<b>Title/Responsibility</b>	<b>Name/Qualification</b>	<b>Agency Affiliation</b>	<b>Email/Phone</b>
Project Manager/directs day-to-day work of project	Laurel Marcus, 30 years watershed professional	Director, CLSI	laurelm@fishfriendlyfarming.org (707) 253-1226
Quality Assurance manager	Qualified professional, hydrologist	CLSI	
Contractor /Staff	Field work	CLSI	
Land Manager	Specific to chosen tributary and participating landowners		

### **SECTION 3.0 EXPERIMENTAL APPROACH**

For details on the approach and procedures for establishing a stream flow gaging station, refer to APPENDIX A: Stream Flow Monitoring Protocol. The following subsections provide an overview of the approach and identify relevant QA/QC procedures.

#### **3.1 Site Selection**

Because the location of the monitoring station is the crucial step in providing representative data, a qualified professional will determine the site selection. At sites on alluvial channels, where few locations will meet the criteria, the choice will be identified as the best available, with an assessment of how the flow measurement may be affected. The qualified professional will fill out the Data Sheet #1 in Appendix B: Site Selection Checklist. Site selection will be assessed as achieving the requirements according to a low, medium, or high rating, with notes to explain the choice. This rating will help assess the quality of the gaging data.

The site for the stream gaging station should be the best available and meet as many of the criteria listed in Appendix A: Stream Flow Monitoring as possible. The site will need to accommodate the water level recorder and the staff gage. It will also be where the cross section is surveyed and related to a permanent benchmark that can be located easily every year.

Discharge measurements will be taken in the general area of the site. An evaluation form to assess how the site's features will affect discharge measurements is listed in Appendix B.



These considerations will be taken into account by the qualified professional, who, in consultation with the landowner or manager, will determine the site selection for the stream gaging station.

### **3.2 Water Level Recorder Device Selection**

The qualified professional, in consultation with the landowner or manager, will determine if the site is appropriate for a stilling well, a bubble system, a pressure transducer, an acoustic recorder, or another water level recorder device. Stilling wells and bubble systems need adequate space for the gaging house and require significant investment; pressure transducers are the most likely fit for most sites, but are susceptible to scour and siltation; acoustic recorders are good choices for sites beneath bridges, but need water free of algae and debris.

The Stream Flow Monitoring Protocol in Appendix A includes Table 1, which compares pressure transducer devices currently available, one bubble system device, and acoustic recorders. To assure data accuracy, the qualified professional will choose a water level recorder device with a range of water depth closest to the expected range to be monitored.

The devices listed in Table 1 range in accuracy claims depending on the device and temperature. The accuracy standard expected for data in the Stream Flow Monitoring and Coordinated Diversions Pilot Study is 0.01 ft. or 0.2% of the total depth the instrument is rated for, whichever is greater. The staff gage is the reference for the water level recording device. A staff gage that can be read to 0.01 ft. is required to conduct the accuracy checks on the continuously recording water level device (see “Station Maintenance QA/QC Checks” in Section 6.0 QA/QC checks).

### **3.3 Installation of Water Level Recorder and the Staff Gage**

The water level recorder installation will depend on the type of device selected for the station (refer to Stream Flow Monitoring Protocol, Appendix A). The stilling well and bubble system require a site that can accommodate gage housing. The pressure transducers need a site where a plastic pipe can be affixed to a stable structure or post near the point of low flow

The staff gage is a non-recording, physical gage secured to a post or other structure on the bank. Low flows and high flows may require two separate but related staff gages. The staff gage is used as a reference and a check for the water level recorder. The expected accuracy of the staff gage is  $\pm 0.01$  ft. or 0.2% of effective range, whichever is greater.

For both the water level recorder and the staff gage, installation should take into account accessibility and safety, especially in times of wet weather and high flow. If the bank is steep, a

site to secure a rope, such as around a large tree or a built structure, could provide a hold to prevent slipping down a slick bank while trying to take a reading or retrieve a sensor.

### **3.3 Cross Section Survey and Benchmark**

The cross section survey will be overseen by a qualified professional experienced in conducting surveys. The final survey will be reviewed by the qualified professional. The protocol for the cross section survey is covered in the Stream Flow Monitoring Protocol in Appendix A.

The person selecting points to measure for the cross-section must recognize slope breaks and take an adequate number of points to assure a reasonably accurate topographic representation of the cross section.

The cross section survey will be tied to point of known elevation using a differential level survey. The protocol for the differential survey is covered in the Stream Flow Monitoring Protocol in Appendix A. A permanent benchmark is chosen that won't wash away, that is adequately identified by GPS readings so that it can be found again each year, and that will provide a point to resurvey the station should an event require relocation. The differential survey needs to be a closed loop so that the elevation of the point at the end of the survey is compared with its beginning value. The acceptable error depends on the total distance of the survey:

$$\text{Acceptable Error} \leq 0.007 \sqrt{(\text{total distance})/100}$$

The cross section survey determines the bottom of the stream used for the stage height zero point for both the staff gage and the water level recorder. It should be accurate to the nearest 0.015 ft. The elevations of the water level recorder and the staff gage will be verified every 1 to 3 years by checking them against the benchmark to make sure they haven't moved.

## **SECTION 4.0 SAMPLING PROCEDURES**

Sampling procedures are covered in Experimental Approach, Section 3.

## **SECTION 5.0 TESTING AND MEASUREMENT PROTOCOLS**

Testing and measurement protocols are covered in Experimental Approach, Section 3.

## SECTION 6.0 QA/QC CHECKS

Quality assurance requirements will be the responsibility of a qualified professional. The professional will have expertise in hydrology, open-channel hydraulics, flow measurement techniques and procedures, and data reduction techniques.

Attention to procedures and maintenance of equipment can reduce errors in measurement and discharge calculations.

Errors in discharge measurements include errors in depth because of soft, uneven, or mobile streambeds, uncertainties in mean velocity associated with vertical-velocity distribution errors, pulsating errors, and systematic errors due to improperly calibrated equipment or improper use of the equipment. Good site selection, which includes an assessment of streambed characteristics, will minimize errors in discharge measurement errors due to depth (see Section 3.1, Site Selection and Appendix B, Stream Flow Gaging Station: Site Selection). Calibration of the current meter is addressed in section 6. 4.

### Quality Assurance/Quality Control (QA/QC)

Quality Assurance/Quality Control is a critical component of all monitoring. QA/QC provides the necessary checks to determine if a dataset is reliable.

The features of a QA/QC program address the following:

- Precision is the measure of how similar repeated measurements are to each other. It describes how well repeated measurements agree.
- Completeness is the fraction of data that must be collected in order to fulfill the statistical criteria of the project.
- Comparability is the degree to which data can be compared directly to similar studies.
- Representativeness is the degree to which data can truly characterize the actual environmental conditions.

### 6.1 Station Maintenance QA/QC Checks

The elevations of the water level recorder and the staff gage will be verified every 1 to 3 years by checking them against the benchmark using surveys to make sure they haven't moved. Variations greater than 0.015 ft. will be recorded in the field log book and incorporated into corrections for subsequent readings.

Read the staff gage to 0.01 ft and compare with the water level recorder. If the recorder is more than 0.01 ft. off (or 0.2% of depth, whichever is greater), record the difference in the logbook and consult with the qualified professional. If the difference is more than 5%, then remove the water level sensor to inspect it. If it is malfunctioning, then replace it with a new sensor. Make sure to record the time and readings in the field logbook before and after removal and re-installation so that errors in flow records can be annotated and pro-rated correctly.

At low flow:

- Check the staff gage to make sure it is clear of debris, readable, sturdily attached, and intact
- Check vent tube and confirm that sensor is in the water
- Inspect sensors for changed positions or blockages that might affect function or reliability
- Check gage housing for accumulated sediment and record the amount if it is affecting the sensor
- Remove woody debris that might alter the water surface elevation at the station and record sediment deposition
- Note flow conditions that are recorded as zero flow, but have flow that is bypassing the station gage

At high flow:

- Inspect for erosion and deposition that will affect the cross section, the sensor, or the staff gage
- Note large scale changes that would increase or decrease resistance to flowing water at high stages

## **6.2 Data Management and Records Management**

The qualified professional and the landowner /manager share responsibility for the field logbook. The qualified professional will set up and periodically review the field logbook, and the landowner or manager at the site will be trained by the qualified professional to maintain the logbook. The field logbook will be routinely reviewed and audited as part of the QA/QC procedures (see Data Review, Audit, and Approval, Section 6.5.1). The field logbook may be an electronic logbook. Following each field day all data entries and data sheets will be copied and filed separately from the logbook in case the field book is lost or damaged.

Continuous water-level data will be stored in computer data files. All raw data files downloaded from the field data logger will be stored in a central office location and a copy burned to a CD or DVD.

Digital photos documenting flow conditions during discharge measurements will be kept in a central office location.

## **6.3 Quality Control for Continuous Water Level Recorder**

Water level sensor operation and accuracy will be verified weekly if possible or at least once every 14 days after installation by comparing the sensor reading with a water level measurement

taken from the staff gage installed at the site (see Station Maintenance QA/QC Checks, Section 6. 1). The time and result of each check will be recorded in the field logbook.

Data logger operation will be checked and verified at the same time. The stored data will be accessed and reviewed to determine if there has been drift, unexplained variation in recorded water levels, or malfunction. If troubleshooting does not resolve a malfunction, the data logger will be replaced, and the time and serial number of the replacement will be recorded in the field logbook.

If the check reveals that the water-level sensor is in error by more than 5% of the water depth at the sensor, then the sensor will be removed and inspected. The time of sensor removal will be recorded in the field logbook. If no reason for the error can be found, the sensor will be replaced by a new sensor, and the time of replacement will be recorded in the field logbook.

#### **6. 4 Calibration of Current Meter (Water Velocity Meter)**

Maintenance and calibration of the current meter will be done in accordance with the manufacturer's operations manual for proper calibration and maintenance procedures. Current meters should be inspected before and after each measurement and tested at the beginning of each round of measurements. Calibration of the current meter by performing a spin test should be done at the beginning of each field trip.

#### **6.5 Validation of the Rating Curve Data**

##### **6.5.1 Data Review, Audit, and Approval**

Immediately after taking discharge measurements at a gaging station, the results of that measurement will be reviewed to determine the adequacy of each measurement for use in developing the station's rating curve. The review will consist of an audit of the field logbook, data records, and data reduction calculations on the stage-discharge measurement data sheet (see Appendix B), and an interview with the personnel who took the measurement. Flow data are inspected for missing entries, sufficiency of significant digits, spurious values, and for elevated flows not associated with runoff events noted at other stations or rainfall records.

If results are judged acceptable, then the stage-discharge measurement data sheet will be approved. If any deficiencies are found, then they will be reviewed in detail with the personnel who took the measurement so that appropriate corrective action is taken to ensure adequacy of future measurements.

## 6.5.2 Maintaining Approved Rating Curve Data

The qualified professional will maintain a copy of approved stage-discharge measurements for all stations and will be responsible for developing each station's rating curve. The flow measurements and discharge calculations will be completed and reviewed in the field by the qualified professional. If the measurements and calculations are not approved, they will be redone.

The current meter measurements and the cross section used will be rated according to ideal conditions, noting features that will produce less accurate measurements (see Stream Flow Monitoring Protocol Appendix A).

The accuracy of the rating curve developed for each stream flow gaging station depends on the number of stage-discharge measurements made at each location and the flow range of those measurements. The minimum requirement is that ten separate stage-discharge measurements be made at each location, consisting of:

- 3 measurements under relatively low flow conditions (dry weather)
- 4 measurements under moderate flow conditions (shortly after a runoff peak, during hydrograph recession)
- 3 measurements under high flow conditions (during the peak of a significant runoff episode)

The rating curve for each station is generated by plotting the stage-discharge pairs on graph paper or using a computer program, then, using visual or mathematical curve-fitting techniques, drawing a smooth curve over the range of the data.

Once a rating curve with a good fit has been established over multiple years at a site, gaging during subsequent years may continue on an as-needed basis to provide three new points per year, one each for low, medium, and high flow, and to fill in any uncertainty or resolve variability on the rating curve.

## SECTION 7.0 DATA REPORTING, REDUCTION, AND VALIDATION

A field logbook (such as *Rite-in the-Rain* All-Weather Level Notebook No. 311) or electronic field logbook will be the record of surveys, measurements, notes, and observation on each gaging station for each visit, including the conditions of:

- Weather
- Staff gage, water level sensor and datalogger (to the 0.01 ft)
- Flow (in cubic feet per second, cfs)
- Floating debris

- Streambank and streambed erosion
- Deposition or debris accumulation
- Upstream and downstream

Water level readings from the water level sensor and the staff gage and the time (date, hour, minute) will be recorded in the logbook when depth-velocity measurements begin and end. Photographs of the site and the flow will be taken on each visit. (Use Appendix B: Stage-Discharge Measurement Data Sheet.)

## **SECTION 8.0 ASSESSMENTS**

Flow data are inspected for missing entries, sufficiency of significant digits, spurious values, and for elevated flows not associated with runoff events noted at other stations or rainfall records.

## **SECTION 9.0 REFERENCES**

Harrelson, Cheryl C; Rawlins, C. L.; Potyondy, John P. 1994. *Stream Channel Reference Sites: An Illustrated Guide to Field Technique*. Gen. Tech. Rep. RM-245. Fort Collins, CO: U.S. Department of Agriculture, Forest Service, Rocky Mountain Forest and Range Experiment Station. 61 p.

McCobb, Timothy D. and Peter K. Weiskel. 2003. *Long-Term Hydrologic Monitoring Protocol for Coastal Ecosystems*. U.S. Geological Survey Open-File Report 02-497

Rantz, S. E. 1982. *Measurement and Computation of Stream Flow: Volume 1. Measurement of Stage and Discharge*. U.S. Geological Survey Water-Supply Paper 2175

Sauer, V. B., and Meyer, R. W. 1992. *Determination of Error in Individual Discharge Measurements*: U.S. Geological Survey, Open-File Report 92-144, 21p.

Sauer, V.B., and Turnipseed, D.P. 2010. *Stage Measurement at Gaging Stations: U.S. Geological Survey Techniques and Methods* book 3, chap. A7, 45 p. (Also available at <http://pubs.usgs.gov/tm/tm3-a7/>.)

U.S. Geologic Survey website, [www.usgs.gov](http://www.usgs.gov)

Washington Conservation District. 2007. *Standard Operating Procedure (S.O.P.) No. 1: Flow Monitoring*, Version 2.

**APPENDIX A**

**STREAM FLOW MONITORING PROTOCOL**



## **APPENDIX A: Stream Flow Monitoring**

### **INTRODUCTION**

Monitoring stream flow involves a series of steps to develop a reliable dataset. Each step requires attention to detail and may need professional judgment to evaluate field conditions and determine the best location for measurements.

In tributary basins, stream flow may need to be monitored in a number of locations. The steps in establishing a stream flow monitoring station include:

- 1) Selecting the gaging station locations
- 2) Selecting the type of gage
- 3) Installing the gage
- 4) Surveying the channel cross section and points of known elevation at the gage site
- 5) Completing discharge measurements
- 6) Creating a stage/discharge rating curve for the station
- 7) Maintaining the elevation and stage/discharge rating through continued measurements
- 8) Managing data

Stream flow is typically described in cubic feet per second (cfs) or the volume of water moving past the monitoring station per unit of time. This volume can vary greatly throughout the year, so stream flow needs to be continuously monitored in the most accurate manner possible.

There are several types of instruments used for stream flow monitoring that measure the stage or depth of the flow. Stage is the elevation of the surface of the water above the channel bottom. Several additional steps are needed to relate the stage measurements to actual elevations and to convert them to discharge or cubic feet per second. These additional steps make the stage measurements at one station relevant to other stations and to diversions. These measurements are carried out when establishing the station and revised over time to maintain the accuracy of the monitoring data.

These are key references for stream flow monitoring:

- Harrelson, Cheryl, C.L. Rawlins and John Potyondy. 1994. ***Stream Channel Reference Sites: An Illustrated Guide to Field Techniques***. USDA Forest Service Report RM-245.
- McCobb, Timothy D. and Peter K. Weiskel. 2003. ***Long-Term Hydrologic Monitoring Protocol for Coastal Ecosystems***. U.S. Geological Survey Open-File Report 02-497
- Rantz, S. E. 1982. Measurement and Computation of Stream Flow: Volume 1. ***Measurement of Stage and Discharge***. U.S. Geological Survey Water-Supply Paper 2175
- Sauer, V.B., and Turnipseed, D.P., 2010, ***Stage measurement at gaging stations: U.S. Geological Survey Techniques and Methods*** book 3, chap. A7, 45 p. (Also available at [http://pubs.usgs.gov/tm/tm3-a7/.](http://pubs.usgs.gov/tm/tm3-a7/))
- U.S. Geologic Survey website, [www.usgs.gov](http://www.usgs.gov)

## **APPENDIX A: Stream Flow Monitoring**

### **Constraints**

The biggest constraint to the development of high quality datasets for stream flow monitoring is the location of the monitoring station. Poorly located stations will not provide accurate measurements of streamflow. Typical problems include stations that do not allow for measurement of all of the flow passing the site due to losses to groundwater, choice of a site with multiple channels, or a wide area of flow at higher flows, or a wide and shallow flow at low water, or sites located in a meander of an alluvial channel. Data from poorly selected stations have limited value. Another constraint is a lack of frequent checks and measurements to maintain the gage site and rating curve. Finally, it should be recognized that several-to-many years of data and analysis are needed to produce datasets to characterize stream flow for a particular location.

### **Quality Assurance/Quality Control (QA/QC)**

Quality Assurance/Quality Control is a critical component of all monitoring. QA/QC provides the necessary checks to determine if a dataset is reliable.

The features of a QA/QC program address the following:

- Precision is the measure of how similar repeated measurements are to each other. It describes how well repeated measurements agree.
- Accuracy measures how close results are to a true value and can be determined through comparison to a standard or reference measurement.
- Completeness is the fraction of data that must be collected in order to fulfill the statistical criteria of the project.
- Comparability is the degree to which data can be compared directly to similar studies.
- Representativeness is the degree to which data can truly characterize the actual environmental conditions.

A separate QAPP (Quality Assurance Project Plan) has been prepared for this protocol and QA/QC procedures are included here.

### **1. SELECTING STREAM FLOW GAGING STATION LOCATIONS**

The selection of stream flow gaging sites is the most critical step in producing reliable data which accurately represents stream flow levels in a creek.

The purpose of installing a stream flow gage is to create a continuous record of the depth and volume of flow at the station. There are a number of features needed for a good stream gaging location including:

- The general course of the stream is straight for about 300 ft. upstream and downstream from the stream gaging site
- The total flow is confined to one channel at all stages, and no flow bypasses the site as subsurface flow
- The streambed is not subject to scour and deposition and is free of aquatic growth
- Banks are permanent, high enough to contain floods, and free of brush
- A pool is present upstream from the control at extremely low stages to ensure recording a stage at extremely low flow and to avoid high velocities near stream gaging station intakes during periods of high flow

## **APPENDIX A: Stream Flow Monitoring**

- The stream gaging site is far enough upstream from the confluence with another stream to escape from any variable influence the other stream may have on the stage at the stream gaging location
- A satisfactory reach for measuring discharge at all stages is available within reasonable proximity of the stream gaging station (it is not necessary that the low and high flows be measured at the same stream cross-section)
- The site is readily accessible for ease in installation and operation of the stream gaging station

In the Napa River, there are two large categories of stream channels: those confined in a canyon or within a streambed of bedrock, and those unconfined with an erodible gravel/cobble bed. Confined channels occur mostly in the mountains. Rock dominates the streambed controlling the channel location and width. Alluvial channels are not confined in canyons or gorges, but instead course over the broad river valley. The channel bottom is made up of cobble, gravel and sand and stream flow may infiltrate into the gravel bed at certain times of the year (Figure 1).

### Methods

For a particular tributary basin of interest, the perennial streams provide the main area for stream gaging.

- On a topographic map or using a Geographic Information System (GIS), identify the blue line streams in the tributary basin.
- Identify the reaches of each stream in rockbound areas such as mountain gorges. These are likely naturally confined channels.
- Identify the reaches of each stream in alluvial valleys. These are probably unconfined channels.
- Identify the alluvial fans in the basin

### Choosing a Location

In the rockbound confined channels (Figure 2), it may be easier to find locations which fit the needed features for gaging stations. These include:

- straight channel
- limited scour and deposition
- little loss of flow to groundwater
- no secondary channels
- banks are permanent and high enough to contain floods
- pools are more likely to be present year-round
- a cross-channel weir can be an excellent site for a gaging station

In these confined channels, flood flows can be deep and very swift so the instrument may need to be carefully placed to avoid damage or loss. It may also be difficult to access the site at high flow to complete discharge measurements.

In alluvial channels (Figure 3 and 4), it is more difficult to identify gaging sites which fit the needed features for a gaging station. These include:

- Alluvial fans located at the rock canyon outlet of the creek infiltrate large amounts of stream flow. The channel may be straight though the fan, but the loss of flow to groundwater makes these poor gaging locations (Figure 5)
- alluvial channels may also gain flow from groundwater during certain seasons or in particular locations

## APPENDIX A: Stream Flow Monitoring

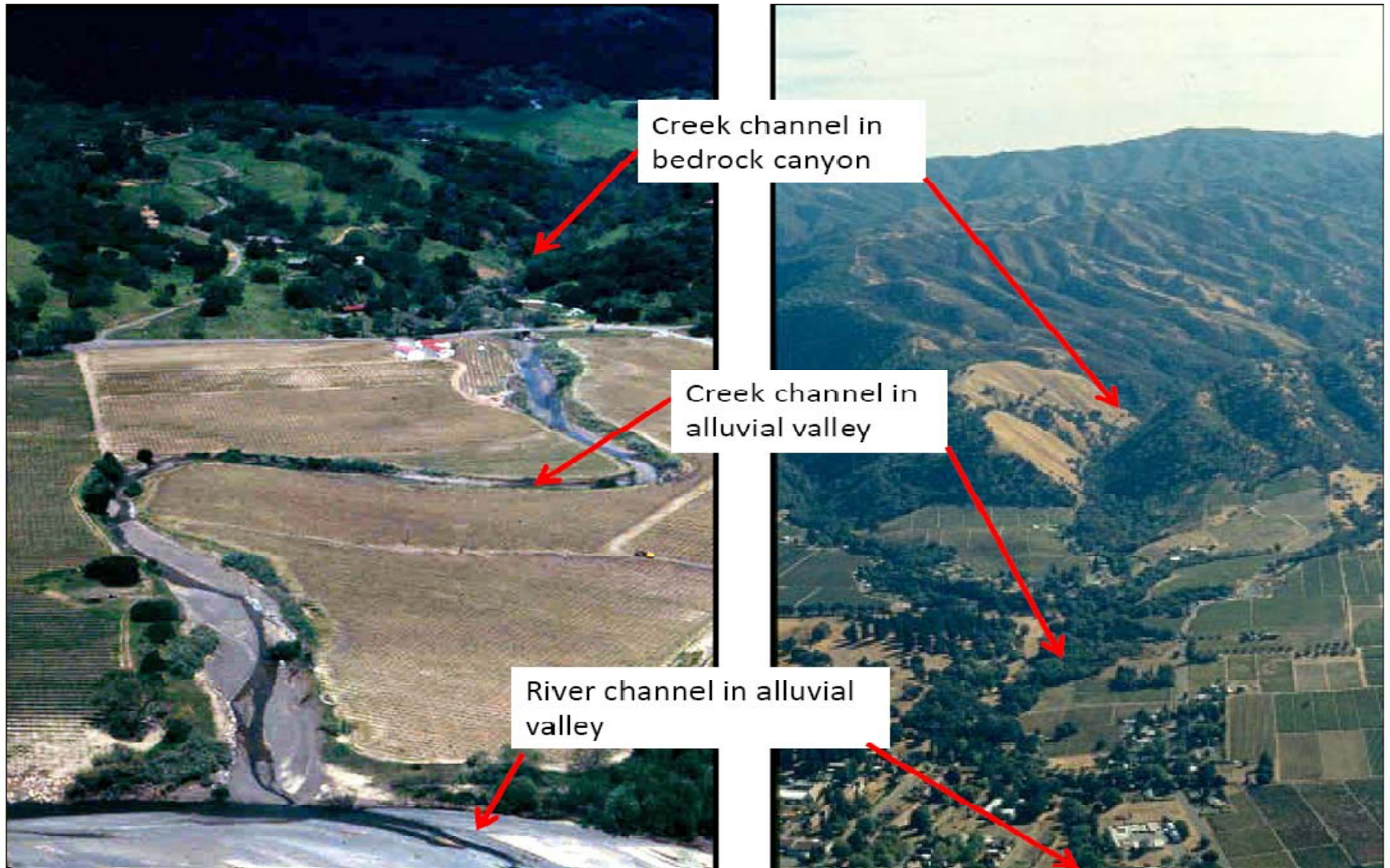
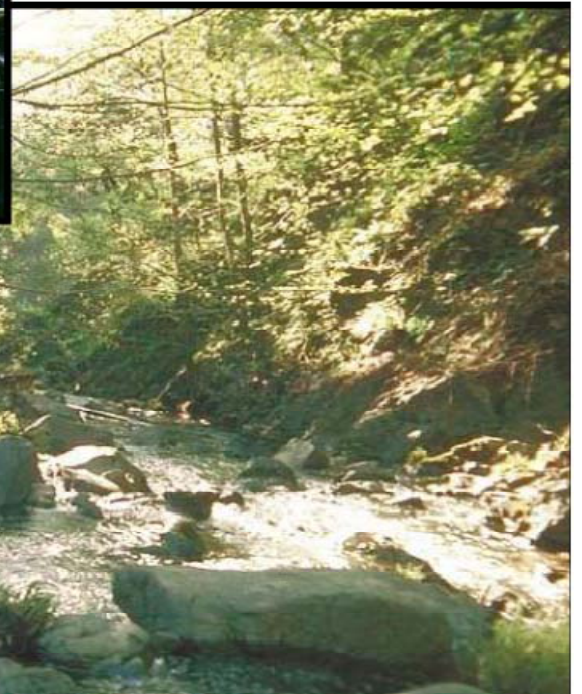

Figure 1: Different types of channel occur in different areas of the watershed

## APPENDIX A: Stream Flow Monitoring



**Rock bound channels  
do not lose much  
flow to groundwater**

**Figure 2: Confined stream channels**

**APPENDIX A: Stream Flow Monitoring**

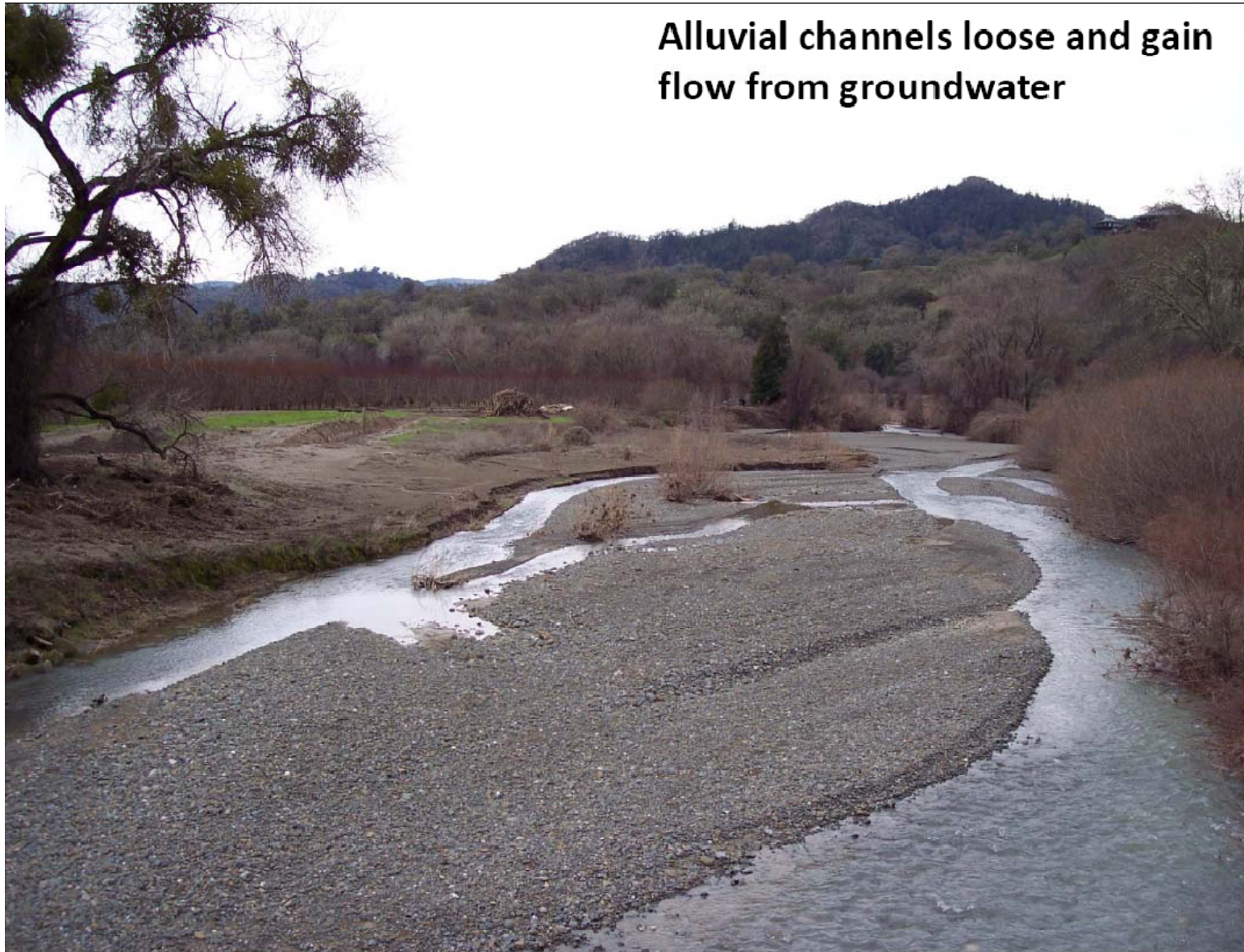

**Alluvial channels loose and gain flow from groundwater**

**Figure 3: Example of an alluvial stream channel**

## APPENDIX A: Stream Flow Monitoring

**General course of the stream is straight for about 300 ft upstream and downstream from the stream gaging site. These example streams meander.**



**Figure 4: Selection of the gaging site should avoid meandering stream areas**

**APPENDIX A: Stream Flow Monitoring**

**Total flow is confined to one channel at all stages, and no flow bypasses the site as subsurface flow**



**Alluvial fan where stream flows infiltrate into the alluvial basin**

**Figure 5: Alluvial fans are areas of high infiltration of surface flows into groundwater and are not good locations for gaging stations**



## APPENDIX A: Stream Flow Monitoring

**The stream gaging site is far enough upstream from the confluence with another stream to escape from any variable influence the other stream may have on the stage at the stream gaging location**



**Figure 6: Tributary confluences do not make good gaging site**

## APPENDIX A: Stream Flow Monitoring



**A satisfactory reach for measuring discharge at all stages is available within reasonable proximity of the stream gaging station (it is not necessary that the low and high flows be measured at the same stream cross-section)**

**General course of the stream is straight for about 300 ft upstream and downstream from the stream gaging site**



**Figure 7: Straight channel reach**

## APPENDIX A: Stream Flow Monitoring

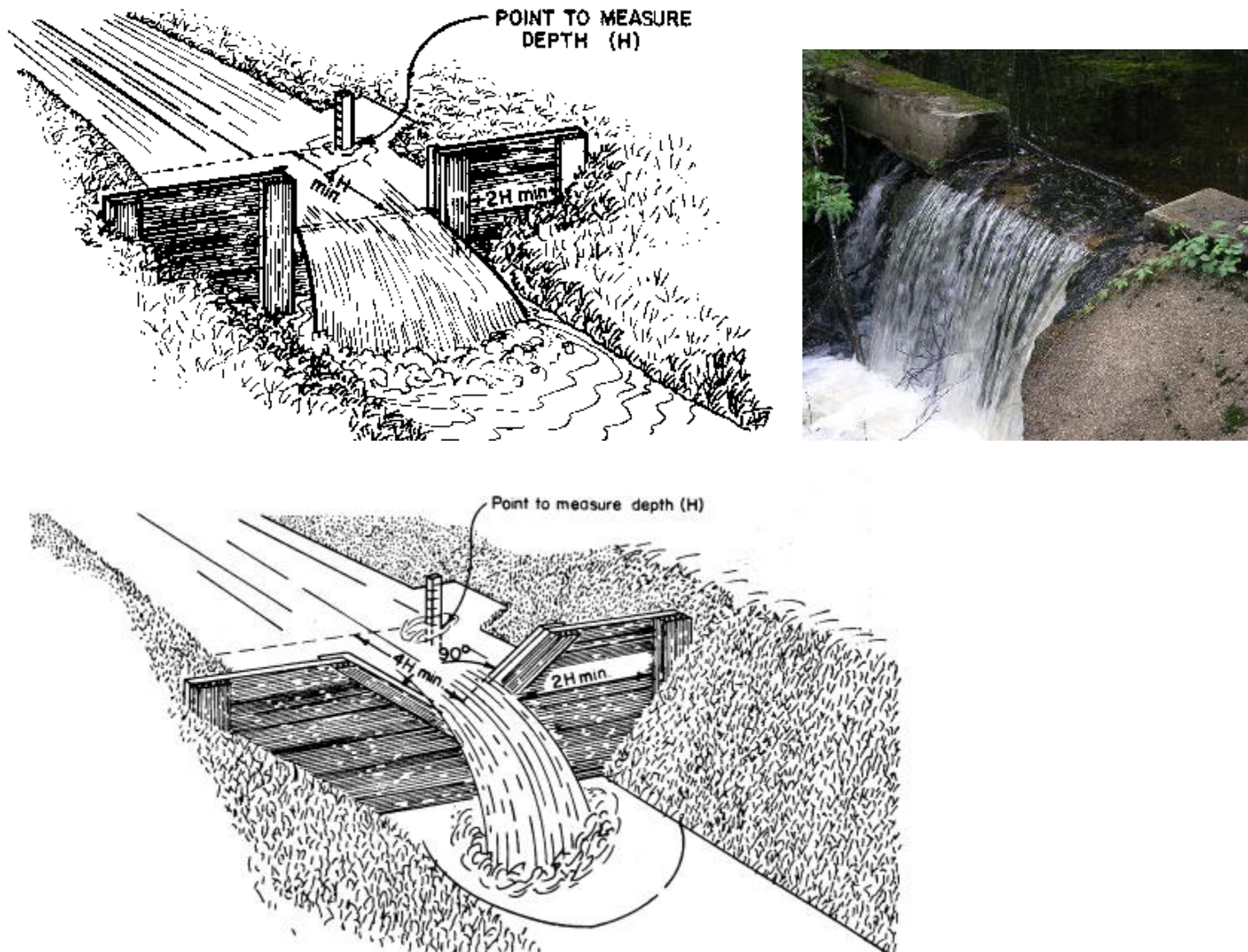

Figure 8: Weirs are often good locations for gaging sites and provide a stable grade control for low flow measurements

## **APPENDIX A: Stream Flow Monitoring**

- many unconfined alluvial channels meander and straight channel sections are often short (Figures 4, 6 and 7)
- most alluvial channels experience scour and deposition and do not have “permanent” banks
- alluvial streams may not have pools during low flow conditions and may dry up in summer

Locations for stream flow gages in alluvial channels need to be carefully chosen. Bridges and weirs are often good choices (Figure 8). The weir can provide a long term grade control to create a stable site for measuring discharge. It may also be possible to install a Parshall flume. Because alluvial channels lose flow to groundwater, subsurface water levels and, in some locations, river stage also has to be measured in order to correctly characterize stream flow processes.

In choosing a stream gage site, the landowner will need to approve of the use of the site and sign a landowner access agreement. Fill out Data Sheet #1 for each gage site.

### **2. SELECTING THE TYPE OF GAGE AND INSTALLING THE GAGE**

The most common stream flow monitoring instruments are: 1) water level recorder installed in a stilling well on the stream bank or at a bridge pier; 2) bubble system gage; 3) pressure transducer installed in a pipe set on the bed of the stream; 4) acoustic water level recorder installed on the underside of a bridge or similar structure. Each type of instrument provides continuous recording of water stage or elevation. The accuracy level of the gage in recording water stage should be  $\pm 0.01$  ft.

#### **Stilling Well**

Water from the creek enters and leaves the stilling well through underwater pipes, allowing the water surface in the stilling well to be the same elevation as the creek water surface (Figure 9). The stage is measured inside the stilling well using a pressure, optic, or acoustic sensor. Many locations are not physically appropriate for installing a stilling well and pipe system in the stream bank.

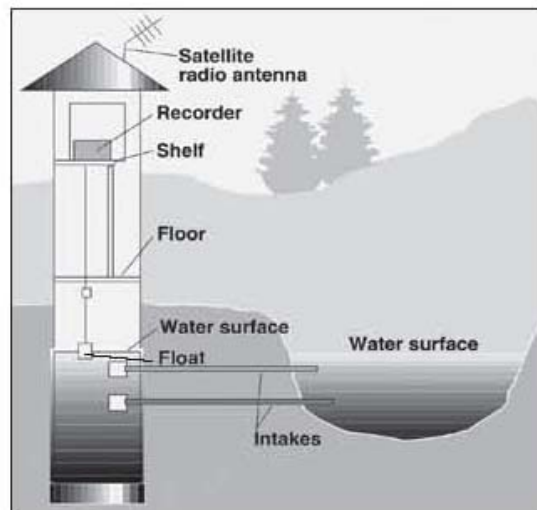
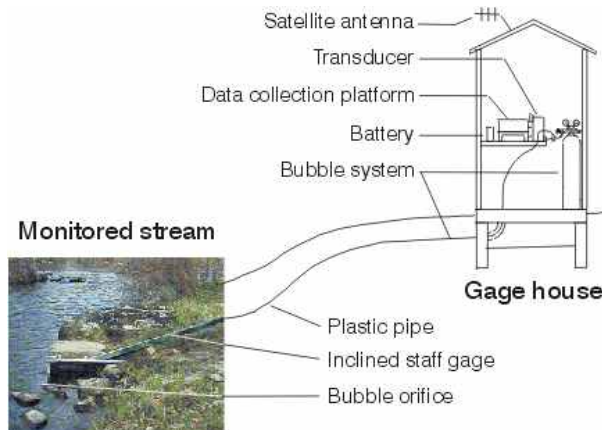

**Figure 9: Stilling well type stream flow gage**

## **APPENDIX A: Stream Flow Monitoring**

### **Bubble System**

This type of gage is established with a permanent gage house similar to the stilling well. A long, open-ended pipe extends from the gage to the waterway. The end of the pipe in the creek is fixed securely below the water surface. Pressurized gas is forced through the pipe from the gage house and out the orifice of the pipe. The pressure in the pipe is determined by how deep the water is over the orifice. Change in creek flow provides a change in the pressure in the pipe which is sensed by a pressure transducer in the gage house and recorded by a data logger in the gage house. This type of system is best for a long term permanent gage site.



**Figure 10: Bubble system type stream gage**

### **Pressure Transducer**

These instruments measure the weight or pressure of the water above the sensor. There are two types of pressure transducers: a differential pressure transducer and an absolute pressure transducer. The differential pressure transducer corrects for barometric pressure by having a vent tube. The vent cannot be submersed and so must be long enough to stay outside the flood zone.



**Figure 11: Example of a differential-pressure transducer. Note the cable extended above the transducer on the wooden lath.**

## **APPENDIX A: Stream Flow Monitoring**

The absolute pressure transducer is enclosed and submersible. It does not correct for barometric pressure. Data have to be corrected for barometric pressure recorded by a separate barometer in the immediate vicinity of the transducer.



**Figure 12: Absolute pressure transducer attached to a wooden lath and secured with nylon ties.**

The pressure transducer records stage at a selected time interval (every 30 minutes, for example). Most transducers record after 0.15 ft. of submergence of the transducer.

The differential pressure transducer is typically placed in a plastic pipe with an open end and the vent cable is stretched through the pipe to a location outside the creek flow. The transducer is submersible but the data logger is on the “dry” end of the cable. Only the differential pressure transducer can be used with telemetry to produce real time data available on the internet.

### Acoustic Water Level Recorder

These instruments are mounted above the water and emit a sound pulse that bounces back to the instrument, providing a depth reading. High levels of algae or debris can lead to false readings.

### Non-Recording Staff Gage

This type of gage is manually read and provides for a comparison with data from a recording gage. A staff gage consists of a scale marked in feet and tenths on a post or bridge pier in the stream to show the elevation of the water surface. The staff gage should be located where a continuous recording gage will be used in order to provide an accuracy check for the recording gage. The staff gage is located such that the lower end of the scale is in the channel at low flow. The scale can be calibrated to elevation using the same surveyed cross section as the recording gage.



**Figure 13: Staff gage**

## APPENDIX A: Stream Flow Monitoring

Table 1 provides a comparison of the features of some water level recorders.

TABLE 1. STREAMFLOW MONITORING INSTRUMENTS								
Company & Product	Logger	Available Applications	Memory Size	Battery Life	Accuracy	Telemetry Compatible	Cost	Comments
Solinst Levelogger <a href="http://www.solinst.com">www.solinst.com</a>	Levelogger – sealed, cable not required, user defined, linear and event-based sampling modes, need Barologger to correct for barometric pressure (in 20 mile radius). Several types					Yes, using data logger with cable. Solinst telemetry system or SDI-12 network via cable. 9100 STS telemetry system has cellular, satellite, landline, and radio options	Levelogger: \$595 Barologger: \$487	In field download cable and 3001 leveloader. Logger can be used for wells also. Cable, software extra.
	3001 Gold Levelogger 7/8" x 6"	Depth— Pressure transducer and temperature	40,000 data points	10 years	0.05% FS <sup>1</sup> ±0.05°C	Yes		
	3001 Levelogger Junior	Depth— Pressure transducer and temperature	32,000 data points	5 years	0.1% FS	Yes		
	LTC Levelogger Junior	Depth— Pressure transducer , temperature, and conductivity	16,000 data points	5 years	0.1% FS	Yes		

<sup>1</sup> Full Scale or FS is the maximum measurable pressure for a particular measurement instrument. To have the most accurate data, choose a pressure transducer with a range of water depths closest to conditions to be monitored.

## APPENDIX A: Stream Flow Monitoring

TABLE 1. STREAMFLOW MONITORING INSTRUMENTS								
Company & Product	Logger	Available Applications	Memory Size	Battery Life	Accuracy	Telemetry Compatible	Cost	Comments
Onset Water Level Logger <a href="http://www.onset.com">www.onset.com</a>	Loggers defined by depth range; available in stainless steel or titanium							
	U20 Water Level Data Logger 1– 13 ft. depth	Depth-pressure transducer and temperature	21,700 data points	5 years	0.05% FS 0.1°C	No. Need to use a data logger with vented cable so that “live” data is corrected.	USB base station: \$230; shuttle: \$230; Hoboware software with USB cable: \$99; U20 data loggers 1– 13 ft. depth stainless steel (1-9 units): \$495 each; 10-99 units: \$458 each; 100+ units: \$424 each;	Need barometric pressure logger. Can launch and download pressure transducer in field with shuttle. Can purchase kit with datalogger shuttle, software, and case. Also can purchase loggers rated for deeper water.



## APPENDIX A: Stream Flow Monitoring

<b>TABLE 1. STREAMFLOW MONITORING INSTRUMENTS</b>								
<b>Company &amp; Product</b>	<b>Logger</b>	<b>Available Applications</b>	<b>Memory Size</b>	<b>Battery Life</b>	<b>Accuracy</b>	<b>Telemetry Compatible</b>	<b>Cost</b>	<b>Comments</b>
Rickly Hydrological Company <a href="http://www.rickly.com">www.rickly.com</a>	Model 3500 Aqualor Submersible Pressure Transducer has cable and vent tube to automatically compensate for barometric pressure	Depth-pressure transducer and temperature	Need to use separate datalogger mounted out of water. CR 510 – 62,000 data points	Battery is separate	0.002% FSO <sup>2</sup> ± 0.01 ft. ±1.0°C	Yes		25 ft. standard vented cable; logger located out of water
	Model 3550 Submersible Pressure Transducer	Depth-pressure transducer and temperature			±0.1% FS			Cable length must be specified when ordered
	Model 2490 Aqua SPT Submersible PT & Logger	Depth-pressure transducer	6,000 data points	3 years	0.2% FS	Yes		Cable with data logger
	Model 2495 Aqua SPT Submersible PT & Logger	Depth-pressure transducer	24,400 data points	3 years	0.2% FS	Yes		25 ft. cable is standard. Can order up to 500 ft. Comes with software. Deploy in PVC pipe vented for barometric pressure compensation.

<sup>2</sup> FSO=full scale output over temperature range

## APPENDIX A: Stream Flow Monitoring

TABLE 1. STREAMFLOW MONITORING INSTRUMENTS								
Company & Product	Logger	Available Applications	Memory Size	Battery Life	Accuracy	Telemetry Compatible	Cost	Comments
Automata <a href="http://www.automata-inc.com">www.automata-inc.com</a>	Pressure transducer	Depth-pressure transducer		Separate from sensor	±1% FS	Yes – with NanoCourier field station and custom web access at <a href="http://www.automata-inc.com">www.automata-inc.com</a>	\$280	Comes with a 9 ft. cable; can order a longer cable
	Ultra Ultrasonic Level Sensor Sonic velocity	Depth-programmable water level		Separate from sensor	0.25% over temperature range of 40-70°C	Yes – with NanoCourier field station and custom web access at <a href="http://www.automata-inc.com">www.automata-inc.com</a>	\$718	Mounted above stream on bridge or pole
	Bubbler Water Level	Depth- water level		Separate from sensor	±1% FS	Yes – with NanoCourier field station and custom web access at <a href="http://www.automata-inc.com">www.automata-inc.com</a>		Requires stilling well

## APPENDIX A: Stream Flow Monitoring

<b>TABLE 1. STREAMFLOW MONITORING INSTRUMENTS</b>								
<b>Company &amp; Product</b>	<b>Logger</b>	<b>Available Applications</b>	<b>Memory Size</b>	<b>Battery Life</b>	<b>Accuracy</b>	<b>Telemetry Compatible</b>	<b>Cost</b>	<b>Comments</b>
Global Water <a href="http://www.globalw.com">www.globalw.com</a>	WL-16 Water Level Logger	Depth-pressure transducer	81,759 data points	1 year	1% FS	Yes	\$913	25 ft. vented cable with longer cables available; comes with software. Deploy in 2" PVC with data logger located out of creek.
	DCX-22 Self-Contained Level Logger	Depth-pressure transducer and temperature	28,000 data points	10 years	1% FS, 1°C	No	\$989	No cable required; need DCX-22 Baro for barometric pressure correction; comes with software, separate USB cable to computer; order based on expected water depth range
	WL400 – good low flow sensitivity (0.3 ft.) and sensitivity in small stage change  WL- 450 transmitter	Depth -pressure transducer and vented cable				1% FS	Yes	\$566 and \$646

## APPENDIX A: Stream Flow Monitoring

<b>TABLE 1. STREAMFLOW MONITORING INSTRUMENTS</b>								
<b>Company &amp; Product</b>	<b>Logger</b>	<b>Available Applications</b>	<b>Memory Size</b>	<b>Battery Life</b>	<b>Accuracy</b>	<b>Telemetry Compatible</b>	<b>Cost</b>	<b>Comments</b>
Global Water <a href="http://www.globalw.com">www.globalw.com</a>	WL -700 Ultrasonic Level Logger and WL-750 Ultrasonic Level Transmitter	Water level measured from above. Data logger available in four ranges based on distance from water surface			0.5% FS		\$641 and \$877	10 ft. cable
Azonde <a href="http://www.azonde.com">www.azonde.com</a>	Azonde 2220CRV	Depth-pressure transducer, temperature		Solar or battery	0.15 ft.	Yes – designed for telemetry using cellular, wireless, or radio		20-40 ft. cable
Adcon <a href="http://www.adcon.com">www.adcon.com</a>	LEV1 level sensor	Depth-pressure transducer	Designed to work with telemetry stored remotely	3-4 days, but mostly solar-powered	0.1%FS (@ 0-40°C)	Yes	\$2,200 with telemetry	Works with Adcon stations

## **APPENDIX A: Stream Flow Monitoring**

### **3. INSTALLING THE GAGE**

The selection of gage sites should reflect consideration of the purpose of the stream flow gaging project. If floods levels are interest fewer sites may be preferable with sturdy gage installations. If low flows are of interest, more stream flow gages coupled with groundwater measurements may be needed.

The installation process for the gages will be very site specific and should be overseen by a professional hydrologist. The sites will need to be suitable for answering the primary monitoring question and for fulfilling the site selection criteria listed in section 1.

If a stilling well of bubble system gage is to be installed, there needs to be an area adjacent to the channel that can accommodate the gage house and well. It is only feasible to go through the expense of installing these if the gage is meant to be permanent and used for a long period time. A hydrologist with significant experience in establishing gages should determine if this type of gage is appropriate for a particular site.

Pressure transducer gages are easier to install, but are also more prone to damage and loss than the more permanent types of gages. The differential pressure transducer requires a pipe housing with an open pipe at the creek end that extends along the bank to allow for the cable and datalogger to be secured outside the creek flow.



**Figure 14: Pressure transducer in plastic pipe housing**

Sometimes a separate battery is also attached at the upland end. Absolute pressure transducers also require a pipe housing of some type. For both of these gages, the pressure transducer needs to be as close to the channel bottom as possible, or maintained at a fixed elevation above the bottom.

The pipe housing needs to be secured to a post, a bridge, or other structure if the gage is to withstand flood flows. If this site does not allow for securing the gage, it should be removed for the flood season.

## **APPENDIX A: Stream Flow Monitoring**

The holes in the pipe should provide for water level in the pipe to rapidly equalize. However, depending on the gage location, large holes may allow the sediment to accumulate in the pipe. If this occurs, measure the offset from the bottom of the pipe the sediment caused for the transducer and the dates it occurred. If the gage is upstream of a weir, algae buildup on the weir should be cleared frequently to assure proper function and that no debris or other problem is occurring. The staff gage should be read and the value recorded during each visit.

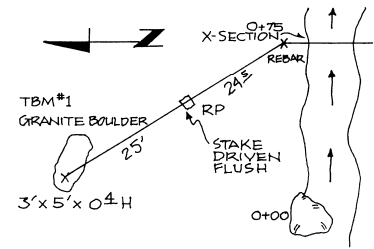

**Figure 15: Map of a benchmark set in a boulder.**

### **4. SURVEYING THE CHANNEL CROSS SECTION AND POINTS OF KNOWN ELEVATION AT THE STATION**

The gage will measure stage or the elevation of water above the stream bed at the station. This elevation needs to be related to a constant reference elevation known as a datum.

A surveyed cross section of the channel is completed at the gage site. The end points are surveyed to an object outside the channel with a known elevation. This object serves as the elevation benchmark allowing for the stage measurements to be converted to elevation and compared to fish habitat surveys and other information.

#### **Establishing a Project Benchmark**

The project benchmark is a permanent mark near the area to be surveyed that can be located every year. The benchmark serves as the vertical or elevation reference point for the survey. Establishing a permanent benchmark is the first step in every survey. A benchmark is a point of known elevation. Sometimes an existing benchmark may be available, for example, benchmarks are often found on or near a bridge. Benchmarks are also marked on USGS topographic maps. If an existing benchmark is found near your survey, use it. Otherwise, establish your own benchmark.

#### **Directions for establishing a benchmark**

- Use a piece of rebar or pipe 3' to 4' long.
- Locate the benchmark where it can be seen from the stream channel. It must be located above the stream channel so that it will not be washed away by high water. Figure 15.
- Choose a location that will not interfere with the landowner's operations.
- Locate the benchmark near an obvious landmark such as a large boulder or tree.
- Drive the rebar into the ground until the top is within a half inch of the ground surface. Write an identifying note on a piece of flagging and tie it to the stake. Bury the flagging with dirt to protect it from the sun.
- Mark the benchmark stake with a second stake. Drive the second stake about 6" from the benchmark stake. It should be 18" to 24" long and rise 6" to 12" above the ground. Increase its visibility by spray painting it or wrap duct tape around it. Tie a piece of flagging to it.
- Draw a detailed map of the location of the benchmark in the survey notebook. Mark the elevation of the benchmark if you know it. Note the distance from the benchmark to two or more obvious landmarks,

## APPENDIX A: Stream Flow Monitoring

such as large trees, boulders, fence posts etc. (Figure 15). Use a GPS to record the coordinates of the benchmark.

If you do not know the elevation of the benchmark, temporarily assume an elevation of 100 feet for the benchmark. Later, you should determine the actual elevation of your benchmark. If your benchmark is destroyed or lost you will then be able to use the actual elevation to establish another benchmark. This will allow you to compare your original survey to a subsequent survey. Another advantage to determining the actual elevation of your benchmark is that you will then be able to compare the elevation data of one gaging station to another, and to in-stream habitat sites. Determine the actual elevation of your benchmark by running a *differential level survey* (see page 28) between a point with known elevation and your benchmark.

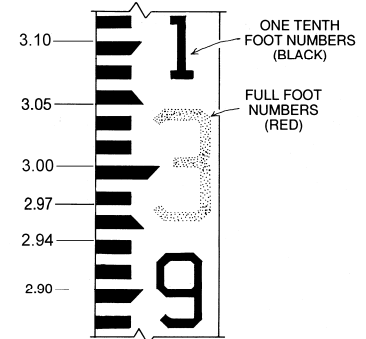

Figure 16: Face of the survey rod

### Surveying: Directions for Instrument Person

#### **Step 1: Setting Up the Tripod**

- Extend the legs of the tripod until the top of the tripod is level with your chin.
- Push one of the legs firmly into the ground. Spread the tripod legs 3' to 4' apart. Push the other two legs into the ground.
- Level the top of the tripod by raising or lowering the legs. The head of the tripod does not need to be perfectly horizontal. However, leveling the instrument will be easier if the tripod head is on a nearly horizontal plane.
- After the head is level check that the leg adjusting screws are tight and that the legs are firmly in the ground.

#### **Step 2: Setting Up the Level**

- Place the instrument on the tripod.
- Screw the level snugly (finger-tight) to the head of the tripod. Do not over-tighten the screw.
- Move the level screws in pairs to bring the bubble into the target circle on the level vial.
- Rotate the scope 90° degrees and re-level.
- Repeat until the bubble stays in the target circle throughout a 360°-degree rotation. This procedure brings the instrument into the range where the self-leveling pendulum prism can operate.
- Turn the telescope to bring the rod into the field of vision.

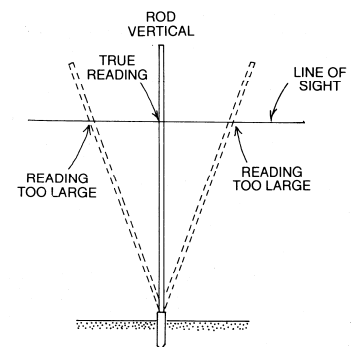

#### **Step 3: Reading the Rod**

The numbers on the face of the rod show the distance measured from the ground in feet. The scale can be read to one hundredths of a foot. Whole numbers of feet are marked off on the scale on the left of the rod by the longer line with an angled end. For example, see the number 3.00 in Figure 16. The number of feet is read at the top of this line and is indicated by the large red numbers. Tenths-of-feet are

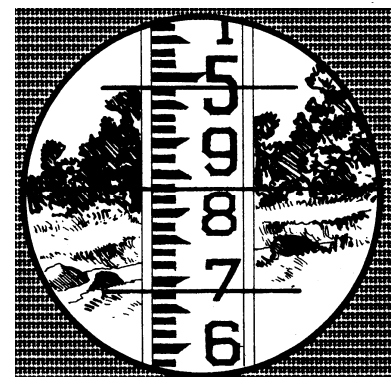

Figures 17 and 18: Reading the rod. The elevation is read at the middle line. The upper and lower lines are called stadia.

## **APPENDIX A: Stream Flow Monitoring**

also marked by a line with an angled end. For example, see the number 2.90 in Figure 16. The black numbers indicates the number of tenths-of-feet.

Each black line and each white space on the scale is exactly one hundredths of a foot. The top of each black line, between the angled tenth-of-a-foot lines, mark off 2/100th's of a foot. Even number hundredths of a foot can be read at the top of the lines. Odd number hundredths of a foot are read at the bottom.

Point the telescope towards the rod. The center crosshairs should cross the face of the rod (Figure 18). Turn the focus knob until the rod can be clearly seen. Adjust the eyepiece to darken or lighten the crosshairs. If the rod is leaning to the side, ask the rod person to move the top of the rod until it is vertical (Figure 17). The rod person should try to keep the rod vertical along your line-of-sight. The center crosshair gives the elevation. Do not use the upper or lower lines for elevation. The upper and lower lines are called stadia. Using the stadia lines to measure distance will be described later.

### **Step 4: Recording the Data**

The survey notebook is the most important piece of surveying equipment. Be neat and orderly so that the data you record can be easily read. Note all pertinent details in your descriptions and field maps. Over the years, the field book will be used to re-locate the benchmark and various survey stakes or markers. The field book will also be the source of data used to analyze the changes in stream shape with time.

Use a *Rite-in-the-Rain* (or equivalent brand) All-Weather Level Notebook No. 311. These books are about 5" x7". They have 48 numbered pages. Each page has six columns. The first page is a blank *Table of Contents*. Be sure to fill in the *Table of Contents* after your survey. Write your name, phone number and project description inside the front cover in the space provided.

Use Figure 21 as a guide to labeling the columns and recording the information for a differential survey. Be sure to draw a map, see Figure 21, showing the location of all the instrument setups, turning points and benchmarks.

### **Surveying: Directions for the Rod Person**

The rod person decides where to set the rod, which is the most critical part of the survey. Place the level on the back of the rod. Use the bubble on the level to adjust and maintain the rod so that it is vertical. Stand behind the rod so that the rod can be held vertical and the level can be read. Holding the rod vertical is essential. If the rod leans forward or backwards the reading will be larger than the true value, see Figure 17.

The rod can be extended to 16 feet. When changing the length of the rod it is essential that each section be fully extended and properly secured. When a section of the rod is fully extended a locking button should pop into place.

### **Measuring Distance**

#### **Measuring with Tape**

- Tapes marked in feet that can be read to the hundredth of a foot can be used to measure distance.
- When measuring horizontal distance stretch the tape tight before making the reading.



## APPENDIX A: Stream Flow Monitoring



**Figure 19: Surveying the channel cross section at a stream flow gaging station**

## **APPENDIX A: Stream Flow Monitoring**

- Do not use a tape to measure the horizontal distance if the tape cannot be stretched out on a horizontal line between the points.

### **Measuring distance with surveying level**

Use the level and the survey rod to estimate distances where stretching a tape would be difficult. To do this read the *stadia*, the short crosshairs above and below the central crosshair on the survey rod.

- Set up the level at one end of the distance to be measured. Place the Survey Rod at the other point.
- Read the rod at the upper and the lower stadia line.
- Subtract the lower stadia reading from the upper stadia reading
- Multiply the difference by 100 to get the distance from the instrument to the rod.

### **Survey the Cross Section at the Gage Station**

- Step 1:** Stretch the tape from the left bank stake to the right bank stake, Figure 19. Read and record the horizontal distance between the stakes. Leave the tape stretched to guide the rod person as he moves from point to point along the cross section.
- Step 2:** Start the survey at the left bank stake. Starting at the left bank facilitates graphing the data. Distances will be referenced to the left bank stake; that is, the distance of the left bank stake will be zero. Take a GPS point for the left bank stake and the right bank stake as the end points of the cross section.
- Step 3:** Set up the surveyor's level along the cross section where you can clearly see both ends of the cross section. A good location to setup is a few feet behind one of the stakes so that the instrument and the two stakes are in line. The instrument can also be set up between the stakes, as long as the top of the stakes are lower than the instrument's line of sight. Setting up on the cross section line ensures that all points on the cross section will be visible and simplifies the calculations.
- Step 4:** Shoot the *backsight* by placing the rod on top of the cross section stake, or other point, whose elevation you have already established. Read the rod and record the value as a *backsight*. Determine the *instrument height* by adding the rod reading to the elevation of the stake.
- Step 5:** Place the rod vertically on top of the left bank stake. Read the rod and record the value as a *foresight*. The distance along the cross section of the left bank stake is zero.
- Step 6:** Place the rod vertically on the ground next to the stake. Read the rod and record the value as a *foresight*. The cross section distance of this shot is also zero.
- Step 7:** The rod person then proceeds to the next slope break or the next channel feature, such as a bankfull indicator, terrace or floodplain. The rod person calls out the type of feature the rod is placed on. The instrument man records the rod reading as a *foresight*.
- Step 8:** The horizontal distance from the left bank stake to the rod is measured and recorded. The distance can be measured using the tape stretched between the cross section stakes. If the tape is too high for the rod person to read the instrument person can read the distance from the instrument to the rod using the stadia lines. If the distance between the rod and the instrument is measured, make sure that it is recorded as such. It will be necessary to convert the distance from, "*the distance from the instrument*" to, "*the distance from the left bank stake*".

## APPENDIX A: Stream Flow Monitoring

- Step 9:** Continue shooting the elevation and recording the distance at each point along the cross section. Finish the cross section by shooting the elevation at the ground next to the right bank stake and on then the top of the right bank stake.
- Step 10:** It is important to determine the elevation of the top of each stake. Each year the elevation of the cross section stakes is checked. Comparing the new elevation of the stake to the elevation of the stake from prior surveys is a good check for errors in the survey. It is also a way of verifying that the stake has not been altered.
- Step 11:** Occasionally you will have to move the instrument to complete the cross section survey. This may happen if an obstacle such as a large tree limb is blocking your line of sight. Remember to set one or two turning points before you move the instrument.
- Step 12:** If you move the instrument remember to close the survey by running a differential survey back to the stake you used as the backsight.
- Step 13:** Plot the data in the field book before you leave the site (Figure 20). Plotting the data helps you catch errors. Make sure that all distances have been converted to, “*distance from the left bank stake*”. Draw a vertical scale that covers the range of elevation values. Draw a horizontal scale that covers the distance between the stakes. The horizontal and vertical scales will be different. Plot each elevation point at the appropriate distance.
- Step 14:** If you discover errors in the data, re-shoot points as needed to correct the problem.

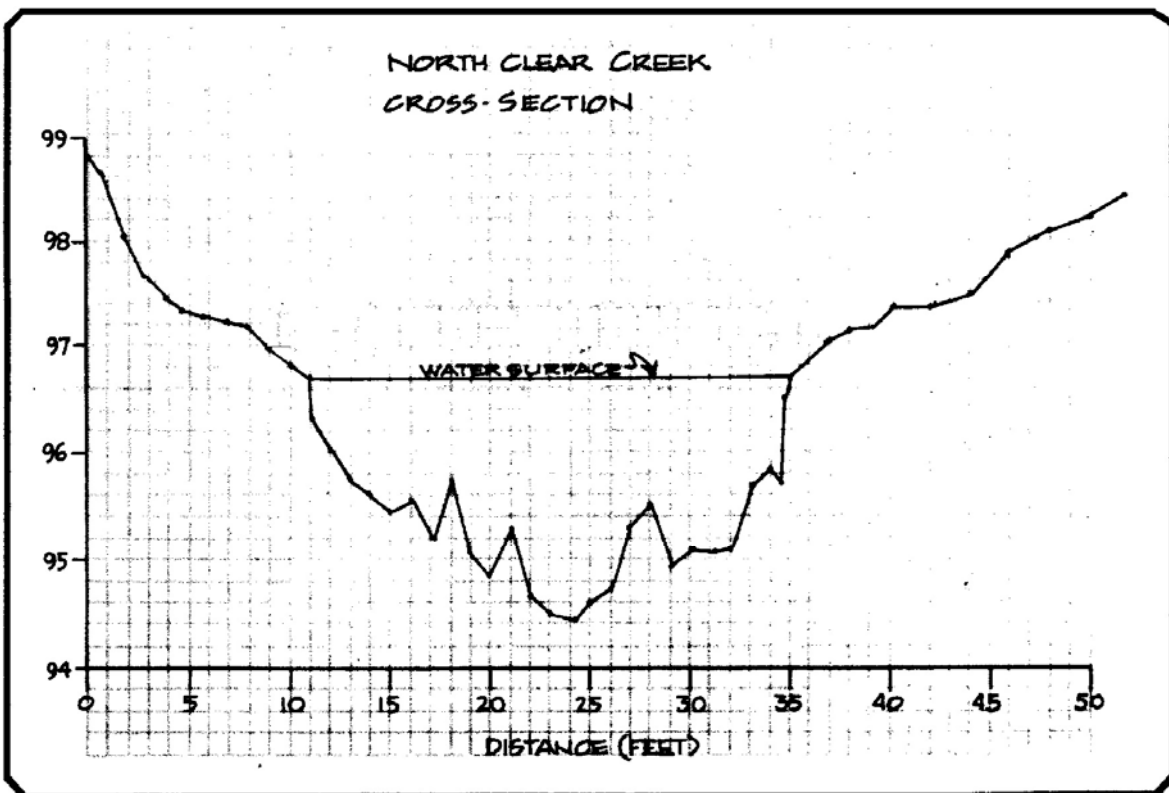
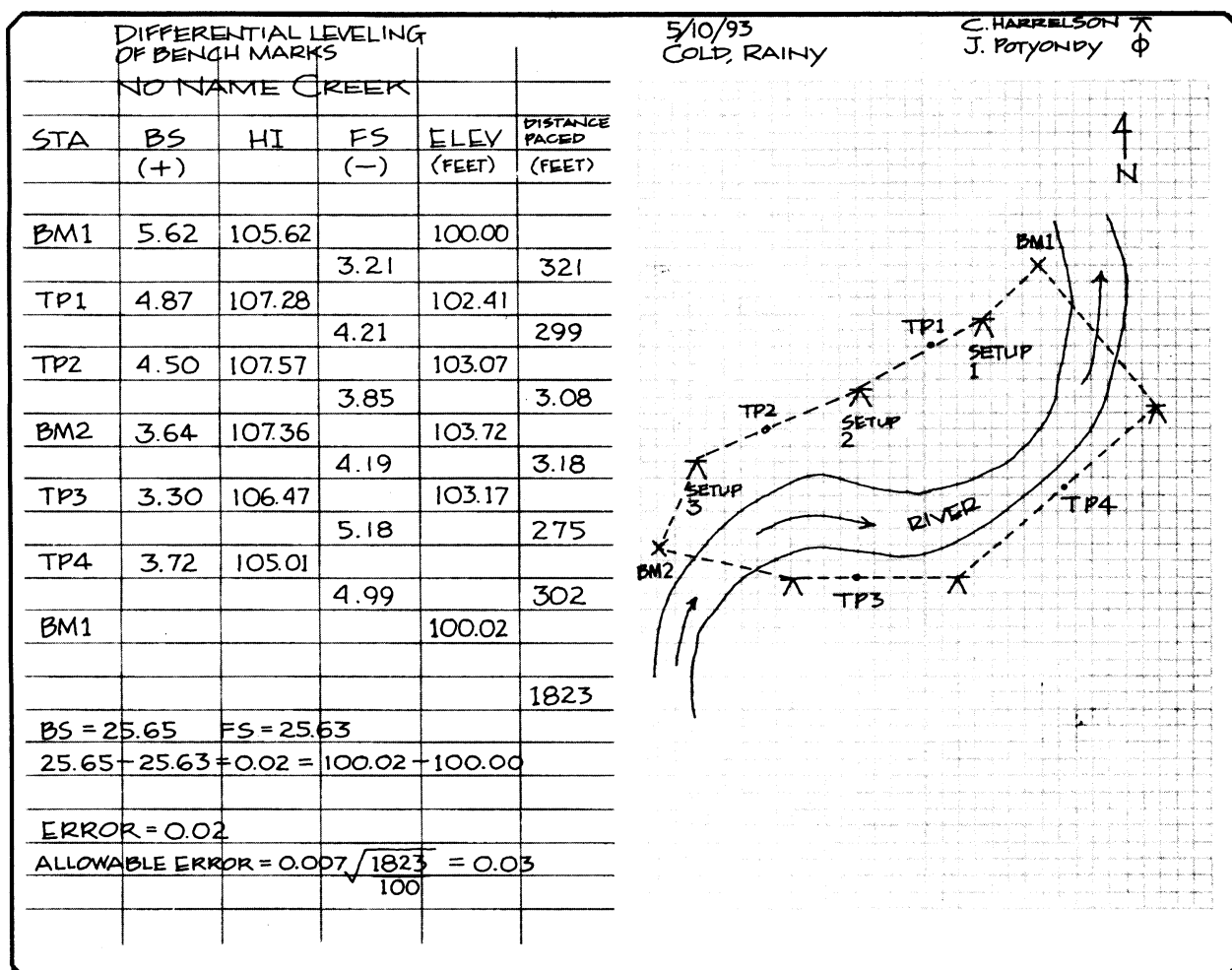

**Figure 20:** An example of a field plot of a cross section. The line labeled “water surface” indicates the water surface at the time of the survey (from Harrelson et al 1994).

## APPENDIX A: Stream Flow Monitoring

### Differential Level Survey

A differential level survey is used to measure the relative elevation of points that are quite far apart. For example, a differential level survey can be used to determine the true elevation of your benchmark if a point of known true elevation is several hundred feet from your site. It consists of making a series of instrument setups along a route that ends back where it began. The route of the survey is called a *traverse*. From each instrument setup, the rod is taken to a point of known elevation to establish the *instrument height*. The instrument height is used to calculate the elevation of new points after the rod is read on the new point. Temporary reference points, called *turning points*, are established before the instrument is moved to a new location. The details of the process are described below.

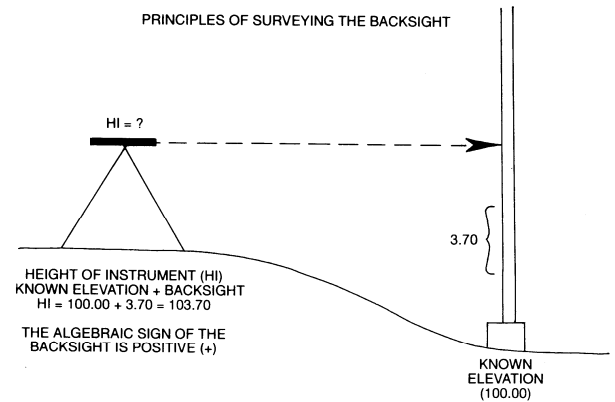

**Figure 21: Field notes from a differential survey. The purpose of the survey is to find the elevation of BM-2 relative to BM-1. The traverse starts at BM-1. Returning to BM-1 closes the survey (from Harrelson et al 1994).**

## APPENDIX A: Stream Flow Monitoring

**Step 1:** The first reading (a reading is also called a *shot*) is to the benchmark. In Figure 21, the benchmark is BM-1. The elevation of the benchmark is known or assumed, Figure 22. If the elevation of the benchmark is assumed it is strongly recommended that you survey from your benchmark to a benchmark with known elevation.

- Place the rod on the benchmark.
- Get the rod vertical.
- Read the scale where the crosshair crosses the rod face.
- Record the reading in the field book as a *backsight*. In the notes, *backsight* is abbreviated as BS.



**Figure 22: Shooting the backsight to find the instrument height.**

**Step 2:** The shot to the benchmark is called a backsight. The backsight reading is added to the elevation of the benchmark to calculate the *instrument height*, see Figure 22. The instrument height is the elevation of the instrument crosshair.

The notes shown in Figure 21 give an example of a differential survey. The elevation of BM-1 is given as 100.00 feet. The backsight to BM-1 is 5.62 feet. Thus, the height of the instrument, for the first setup, is 105.62 feet.

**Step 3:** Use a tape, the stadia method, or pacing to measure the distance from the instrument to the benchmark. Record the distance in the field book. The total distance covered by the survey is used to calculate the allowable error of the survey. This will be explained below.

In Figure 21, the distance was determined by pacing. The distance between BM-1 and TP-1 is shown as 321 feet.

**Step 4:** The rod person should drive a stake in the ground as a temporary reference known as a turning point, TP. The TP should be in the direction of the survey and about the same distance from the instrument as the benchmark. The stake should be solidly in the ground so that it does not shift.

**Step 5:** The rod is then placed on the TP and the instrument person reads the elevation and records it as a foresight, see Figure 23. For example, in Figure 21, the foresight, FS, of TP-1 is 3.21.

**Step 6:** The foresight of TP-1 is subtracted from the instrument height to determine the elevation of TP-1. For example, in Figure 21, the foresight of TP-1 (3.21) is subtracted from the instrument height (105.62) to calculate the elevation of TP-1 (102.41).

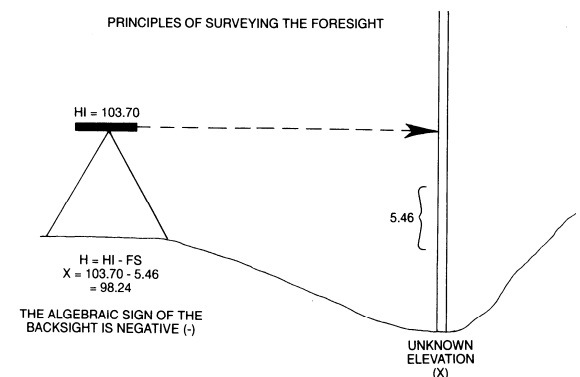
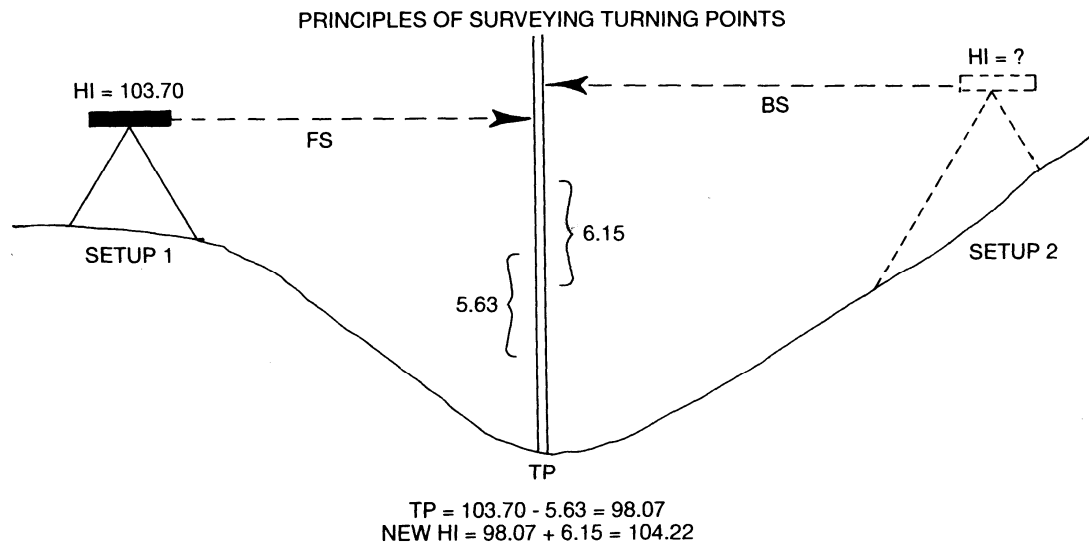

**Figure 23: Shooting a foresight. The instrument height is already known.**

**Step 7:** The instrument is then moved to the other side of TP-1.

**Step 8:** The rod is then placed on TP-1 and the rod is read as a backsight, after the instrument has been setup and leveled. The backsight is added to the elevation of TP-1 to calculate the instrument height, see Figure 24.

## APPENDIX A: Stream Flow Monitoring



**Figure 24: Using turning points to move the instrument.**

For example, in Figure 21, the backsight to TP-1 from setup 2 is 4.87 feet. The backsight (4.87) is added to the elevation of TP-1 (102.41) to calculate the instrument height (107.28) at setup 2.

**Step 9:** The process outlined in steps 1-8 is repeated until the traverse is closed by shooting the original benchmark as a foresight. See the map in Figure 21.

**Step 10:** After you have closed the survey, the elevation of the benchmark at the end of the survey is compared to its original value. This process is known as closing the survey. The difference between the calculated elevation of the benchmark and its original value is the error.

$$Acceptable Error \leq 0.007\sqrt{(total\ distance)/100}$$

The acceptable amount of error depends on the total distance of the differential level survey. One equation to estimate the acceptable error is:

Where the *total distance* is the sum of the distances between the instrument stations in the differential level survey loop. For example, in Figure 21, the total distance of the differential level survey is 1,823 feet and the acceptable error is 0.03 feet.

### **5. COMPLETING DISCHARGE MEASUREMENTS**

Although measuring stage produces valuable information, most gaging data are changed to discharge or volume of water per unit time such as cubic feet per second (cfs). Stage data are changed into discharge data through the completion of discharge measurements and creation of a stage-discharge relation for the particular station.

## **APPENDIX A: Stream Flow Monitoring**

In general, discharge is computed by multiplying the area of water in the channel cross section by the average velocity of the water in that cross section (Figure 25). The continuity of flow equation describes this relationship:

$$\text{discharge} = \text{area} * \text{velocity}$$

Velocity varies over the channel cross section so many measurements must be done to accurately calculate discharge.

A current meter is used to measure velocity at numerous points along a cross section near the gaging station. In this method, the stream channel cross section is divided into a number of vertical subsections. In each subsection, the area is obtained by measuring the width and depth of the subsection, and the water velocity is determined using the current meter. The discharge in each subsection is then computed by multiplying the subsection area by the measured velocity. The total discharge is then computed by summing the discharge of each subsection.

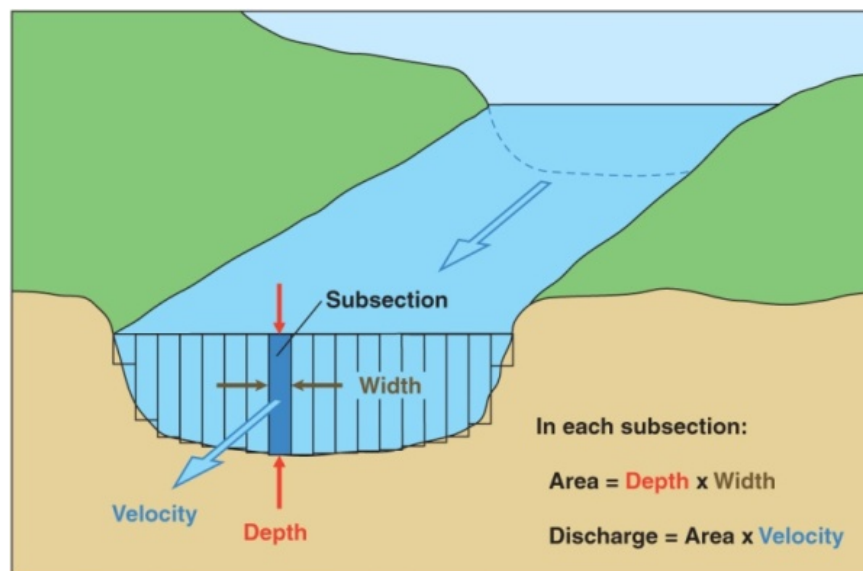

**Figure 25:** Current-meter discharge measurements are made by determining the discharge in each subsection of a channel cross section and summing the subsection discharges to obtain a total discharge (drawing from USGS website).

### Selecting the cross section for the measurement

Choose a location near the gage site where there is a stable channel cross section and a straight section of channel where velocity threads are parallel and there is little slope change. The current should be uniform, free of eddies, dead water near banks, or excessive turbulence. The flow should have primarily downstream current uninterrupted by rocks of different sizes or vegetation. If there is a weir in the channel, measure the current just upstream of the structure. The location of the cross section will not be the same at different flow levels but the features of the location of the cross section should always be the same - even level of flow, minimal turbulence, primarily smooth downstream moving currents without eddies, vertical or side moving currents, unbroken by vegetation. Sometimes rocks need to be re-arranged to create these conditions. Features of the cross section and measurement should be recorded on Data Sheet 2.

## **APPENDIX A: Stream Flow Monitoring**

### Measure channel width and defining subsections

The width of the cross section is measured by stretching a vinyl measuring tape marked in tenths of feet from one edge of the wetted width to the other and perpendicular to the direction of flow. Stake the tape across the width for use in the measurement. This width is then split into subsections with no single subsection carrying more than 5-10% of the total flow. For stream widths of less than 5 ft., the subsections should be spaced at least 0.25 ft. apart. If the stream width is greater than 5 ft. the minimal number of subsections is 15-25. The preferred number is 20 to 30.

### Laying out the subsections

The cross section is determined by measuring the width and dividing it by the number of subsections. For example, if the wetted width is 26 ft. with 20 subsections, each subsection will cover 1.3 ft. The first subsection will extend from the edge of the flow to 1.3 ft (0.0 on the tape) on the measuring tape. The midpoint of this subsection is 0.65 ft. This midpoint is where the current meter reading is completed. The rest of the subsection midpoints are determined by adding 1.3 ft. to the prior midpoint location.

### Current Meters

The velocity of the streamflow is measured using a current meter (Figure 26). There are several types of current meters. Some have rotating cups, other have a pair of electronic contacts on a small head. The older types click for each complete rotation and the operator uses headphones and counts clicks for a set time period. Newer technology has a digital readout. The most common current meter used is the Price AA current meter. The Price AA current meter has a wheel of six metal cups that revolve around a vertical axis. Because the rate at which the cups revolve is directly related to the velocity of the water, counting the revolutions determines the water velocity. Current meters are attached to a wading rod for measuring in shallow waters or are mounted just above a weight suspended from a cable and reel system for measuring in fast or deep water. In shallow water, a pygmy current meter can be used. It is a two-fifths scale version of the meter and is designed to be attached to a wading rod. The pygmy meter can measure velocity in water as shallow as 0.3 ft. Velocity in water shallower than this cannot be readily measured.

### Testing the meter before use

The current meter is a precision instrument, treat it with care. The meter is put together and the cups must spin freely and evenly in order to produce accurate measurements. Every time the meter is used, a test is needed. Using the headphones or digital readout, count the number of revolutions the meter cups make once spun. A count over 45-60 seconds with the manufacturer's specified number of revolutions shows the meter is operating properly.

### Making current measurements using a current meter and top setting wading rod

The wading rod is adjustable to allow for placement of the meter at the 20%, 60%, and 80% level of depth. The depth is measured by placing the wading rod on the streambed and reading the total depth on the wading rod.



## APPENDIX A: Stream Flow Monitoring

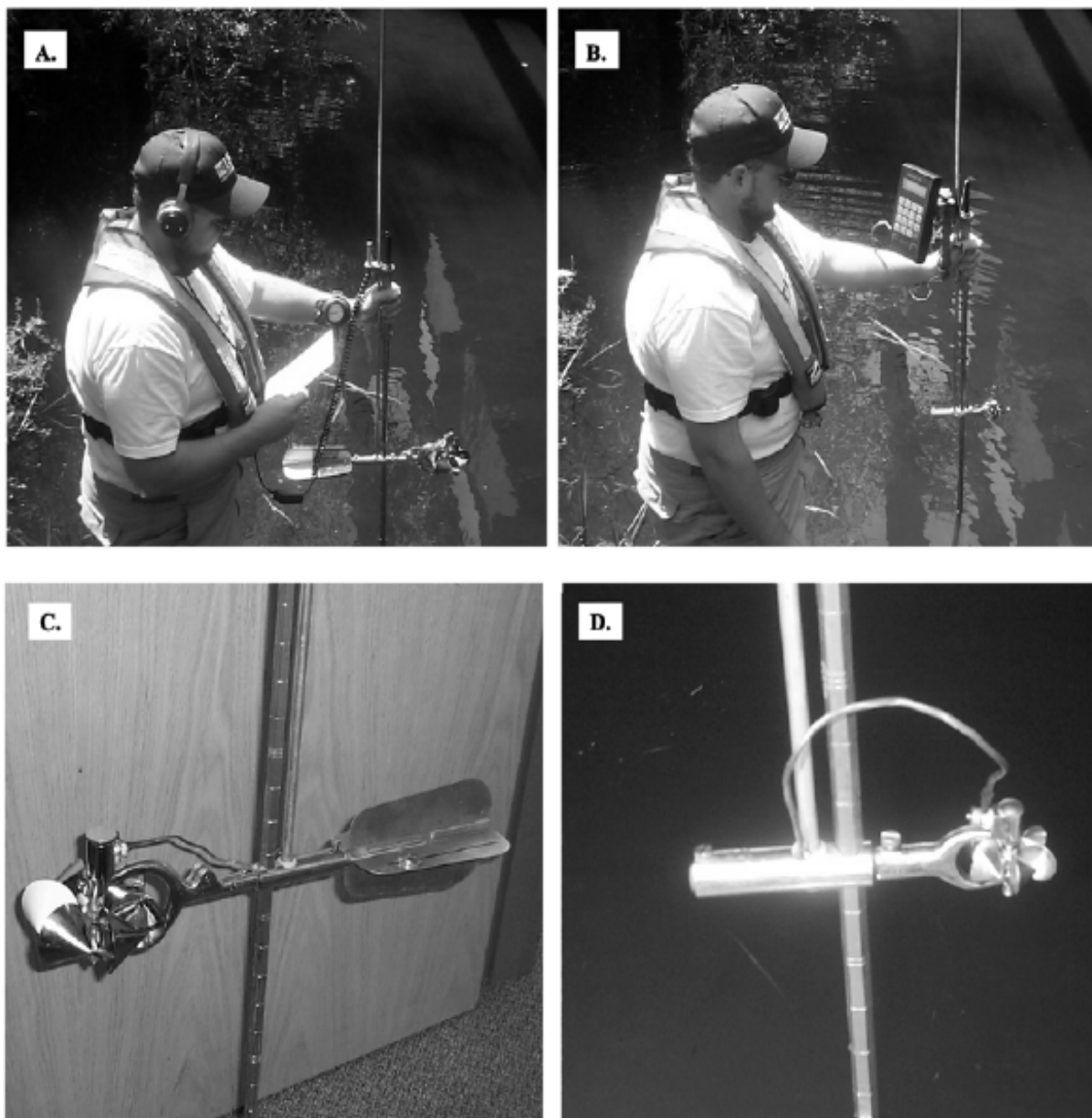

**Figure 26: Types of current meters from McKobb and Weiskel 2003)**

If the depth at the subsection is greater than 30 inches, the velocity is measured at the 20% and 80% water depths at the midpoint of the subsection.

If the water depth is less than 30 inches, the velocity is measured at 60% of the water depth. Keep the wading rod vertical and the current meter perpendicular to the flow.

A team of two people is needed. One person records the data and the other reads and reports the measurements (Figure 27). The measurements start at the left (facing downstream) edge of the water and progresses to the right. The left edge should be recorded as 0.0. At the center of each subsection the

## APPENDIX A: Stream Flow Monitoring



**Figure 27: Discharge measurements**

## APPENDIX A: Stream Flow Monitoring

reader reports the distance (from the 0.0 pt), the total depth, sets the current meter to the appropriate percentage of the depth, and makes the current meter measurement (Figure 28). The reader needs to stand downstream of the cross section when completing the current meter reading. In areas of the channel where the water is deeper or faster, additional readings within the subsection are done. After the reader reports the measurements, the recorder repeats them to confirm the correct number. The current meter reading, if using the type of meter where clicks are counted, is done with a timer. The clicks are counted for a 40-60 second period. Then the number is translated to velocity with a standard table for the particular meter (Attachment 1). Digital meters read out as velocity.

### Calculating the Discharge

After all the measurements are made before removing the tape across the channel, the discharge calculation should be completed in case additional measurements are needed.

When velocity measurement is complete, calculate the total discharge (Q). Determining total discharge accurately is a complex issue, and a variety of methods and equations exist. The mid-section method is currently recommended by the U.S. Geological Survey. (At the risk of offending those with the proper math skills, the method is explained step-by-step.)

The following formula defines the basic method for calculating discharge:

$$Q = \sum (a V)$$

Where Q is the total discharge, a is the area of a rectangular subsection, the product of width (w) and depth (d) for that subsection, and V is the mean velocity of the current in a subsection.

**Step 1** Using the mid-section method, compute the area ( $a_n$ ) of each subsection:

$$a_n = d_n (b_{(n+1)} - b_{(n-1)})/2$$

where  $b$  is the distance along the tape from initial point. "Lost" discharge in the triangular areas at the edges is assumed negligible.

**Step 2** Next, multiply the subsectional area  $a_n$  by the mean velocity  $V$  for the subsection to get the subsection discharge (Q). If only one velocity measurement was taken at 0.6 depth, it is the mean velocity. If two measurements ( $v_1$  and  $v_2$ ) were taken at 0.2 and 0.8 depth, compute the mean value as below:

$$V = (v_1 + v_2)/2$$

**Step 3** To compute the discharge for each subsection, use the equation:

$$Q_n = (a_n V_n)$$

where

$Q_n$  = discharge for subsection n

$a_n$  = area of subsection n, and

$V_n$  = mean velocity for subsection n.

The calculation repeats this process for each subsection, as shown below:

$$Q_1 = (a_1 V_1), Q_2 = (a_2 V_2), Q_3 = (a_3 V_3), Q_4 = (a_4 V_4), \text{ and so on...}$$

## APPENDIX A: Stream Flow Monitoring

BIGHORN NATL. FOREST		8/10/93		DISCHARGE (CONT) 8/10/93					
NORTH CLEAR CREEK		10:05 A.M.		TAPE	WIDTH	DEPTH	VELOCITY	AREA	Q
CLEAR, COOL				(FT)	(FT)	(FT)	(FT/SEC)	(FT <sup>2</sup> )	(CFS)
DISCHARGE MEASUREMENT @ X-SECTION									
PRICE AA METER									
RAWLINS - NOTES      HARRELSON - METER.									
TAPE									
DISTANCE	WIDTH	DEPTH	VELOCITY	AREA	DISCHARGE				
(FT)	(FT)	(FT)	(FT/SEC)	(FT <sup>2</sup> )	(CFS)				
28.0	1.0	0.40	1.618	0.40	.647				
29.0		0.44	1.871	0.44	.823				
30.0		0.93	1.010	0.93	1.939				
31.0		0.52	0.498	0.52	.259				
32.0		0.45	0.45	0.45	.338				
33.0		0.20	0.963	0.20	.193				
REW 34.0	.5	0.30	0.653	0.15	.098				
					19.31				
					CFS				
13.0	1.0	0.22	∅	0.22	∅				
14.0		0.40	0.845	0.40	.338				
15.0		0.44	0.768	0.44	.338				
16.0		0.55	1.388	0.55	.763				
17.0		0.73	1.713	0.73	1.251				
18.0		0.36	1.656	0.36	.596				
19.0		0.58	2.208	0.58	1.281				
20.0		0.70	1.558	0.70	1.091				
21.0		0.64	0.811	0.64	.519				
22.0		0.62	1.821	0.62	1.165				
23.0		2.00	1.352	2.00	2.704				
24.0		1.36	1.483	1.36	2.017				
25.0		1.10	0.149	1.10	.824				
26.0		1.28	1.513	1.28	1.937				
27.0		0.48	2.484	0.48	1.192				

DISCHARGE USING FLOAT METHOD:

AVERAGE VELOCITY ESTIMATED = .50 FT

CHANNEL WIDTH = 34 FT

(A) AREA = 17 FT<sup>2</sup>

(V) VELOCITY (ORANGE PEGEL USED)

DISTANCE = 100 FT

TIME = 85 SEC

82 SEC

83 SEC

84 SEC

87 SEC

AVG TIME = 84.7 SEC

$V = 100 / 84.7 = 1.19 \text{ FT/SEC} \times B = 0.95 \text{ FT/SEC}$

$Q = AV = 17 \text{ FT}^2 \times 0.95 \text{ FT/SEC}$

= 16.15 CFS

**Figure 28: Field notes of discharge measurement (from Harrelson et al 1994).**

**Step 4** The subsection products are then added to get total discharge (Q):

$Q = Q + Q + Q + Q + \dots$  and so on...

Thus, total discharge (Q) equals the sum of all discharges  $\sum (aV)$ , as stated earlier in the basic equation:

$$Q = \sum (aV)$$

A current meter reading should be done every few weeks after the gage is installed and, if water levels fluctuate, more frequently to include low and high flow.

### **6. CREATING THE STAGE-DISCHARGE RATING CURVE**

Stream gages continuously measure stage. This continuous record of stage is translated to river discharge by applying the stage-discharge relation (also called the rating curve). The stage-discharge

## **APPENDIX A: Stream Flow Monitoring**

relation is developed by measuring width and depth and velocity with a current meter over a wide range of stages. These measurements are used to calculate discharge, then plotted against a corresponding measurement of stage recorded with a water level gage. This plot is refined as more discharge measurements are made, especially at the high and low flow levels.

An example of a stage-discharge relation is shown in Figure 29. The stage-discharge relation depends upon the shape, size, slope, and roughness of the channel at the stream gage and is different for every stream gage.

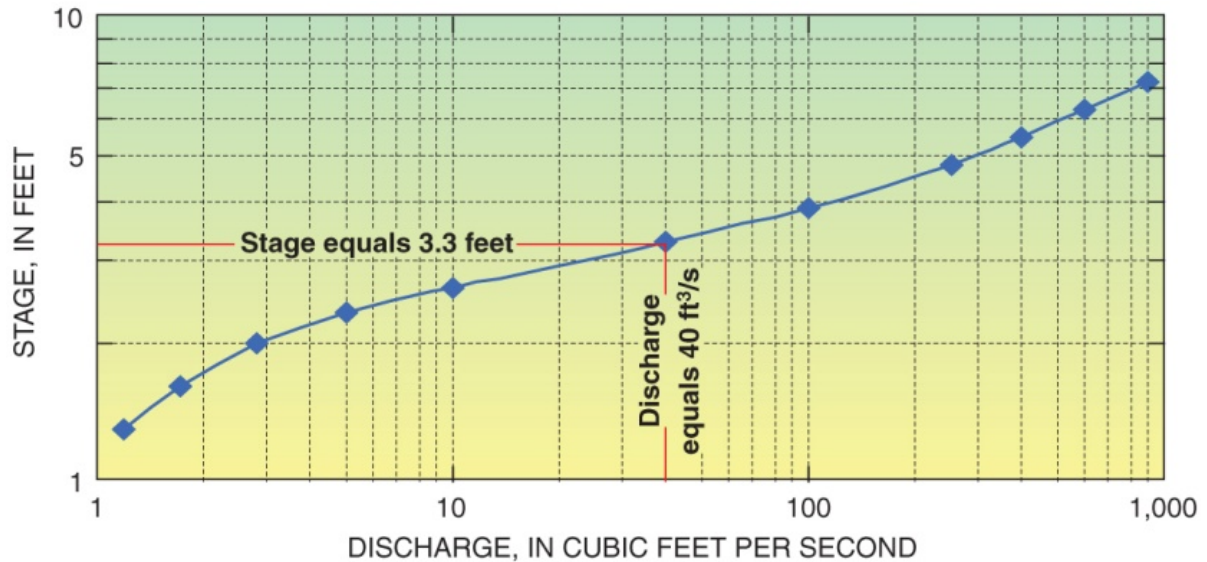
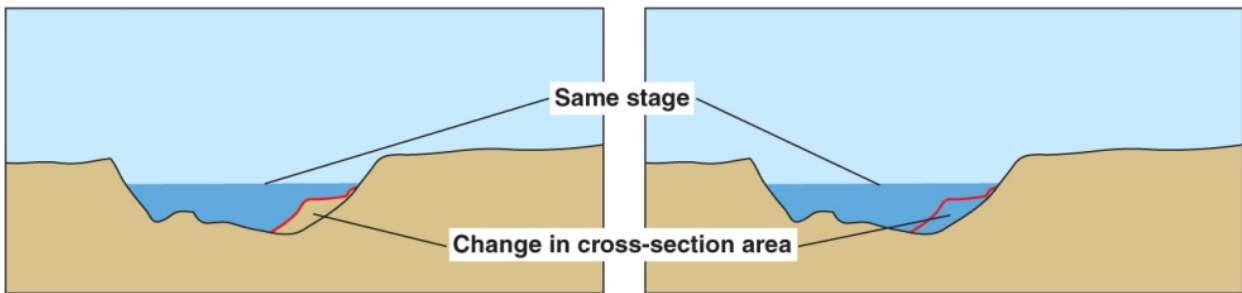

**Figure 29: Example of a typical stage-discharge relation; here, the discharge of the river is 40 cubic feet per second (ft<sup>3</sup>/s) when the stage is 3.30 feet (ft). The dots on the curve represent concurrent measurement of stage and discharge (from USGS website).**

### **7. MAINTAINING THE ELEVATION AND STAGE/DISCHARGE RATING THROUGH CONTINUED MEASUREMENTS**

The development of an accurate stage-discharge relation requires numerous discharge measurements at all ranges of stage and streamflow. In addition, these relations must be continually checked against on-going discharge measurements because stream channels are constantly changing. Changes in stream channels are often caused by erosion or deposition of streambed materials, seasonal vegetation growth or debris. Figure 30 shows an example of how erosion in a stream channel increases a cross-sectional area for the water, allowing the river to have a greater discharge with no change in stage. New discharge measurements plotted on an existing stage-discharge relation graph would show this, and the rating could be adjusted to allow the correct discharge to be estimated for the measured stage.

## **APPENDIX A: Stream Flow Monitoring**



**Figure 30: Erosion of part of a channel results in an increased cross-sectional area in the diagram on the right and the potential for conveying a larger quantity of water at the same stage (from USGS website).**

The cross section at the gage site also needs to be resurveyed after major floods and at least once every 5 years. The survey should verify the datum used when establishing the gage and if the gage has moved determine the change and correct the record as needed.

### **8. MANAGING DATA**

Implementation of this protocol will create two types of data: digital data from data loggers, GPS units and, if used, digital survey data and current meter measurements and surveying notes recorded in field logbooks. Following a field day when the field books are returned to the office all of the prior day's notes and data sheets are copied and placed in a separate file. This assures that the loss of the field book I on a future date will not result in data loss.

Digital files will also be copied and stored on a hard drive that is separate from the location where the original files are stored.

When data sets are reviewed if any adjustments are made a separate spreadsheet of notes will be created with the reviewers initials the date and the reason for the change including the location of other data sources used for the revision.

## **APPENDIX A: Stream Flow Monitoring**

### **Attachment 1**

## STREAM FLOW (DISCHARGE) MEASUREMENT FORM

Stream \_\_\_\_\_

Date \_\_\_\_\_

Station Description \_\_\_\_\_

Time Begin \_\_\_\_\_

Time Ended \_\_\_\_\_

Meter Type \_\_\_\_\_

Observers \_\_\_\_\_

Stream Width<sup>1</sup> \_\_\_\_\_

Section Width \_\_\_\_\_

Observations

Section Midpoint (ft)(m)	Section Depth (ft)(m)(cm)	Observational Depth <sup>2</sup> ft-m-cm	Velocity		Area W x D (ft <sup>2</sup> ) (m <sup>2</sup> )	Flow (Q) V x A (m <sup>3</sup> /s) (ft <sup>3</sup> )
			At Point (ft/s) (m/s)	Average (ft/s) (m/s)		
①						
②						
③						
④						
⑤						
⑥						
⑦						
⑧						
⑨						
⑩						
Total Discharge ( $\Sigma Q$ )(ft <sup>3</sup> /s)						

<sup>1</sup>Make a minimum of 10 measurements when the total width is > 5.0 ft., 20 measurements preferred.

<sup>2</sup>Measure at 60% of depth from surface where < 2.5 ft. deep. Measure at 20% and 80% of depth in waters > 2.5 ft. deep.





9-275-F (Rev. 10-81) UNITED STATES DEPARTMENT OF THE INTERIOR GEOLOGICAL SURVEY WATER RESOURCES DIVISION

Sta. No. 01058783 DISCHARGE MEASUREMENT NOTES Checked by ...

Herring River near Wellfleet, MA

Date Sept 26, 2000 Party R. Fogel, B. G. in (NPS)

Width 3.05 Area 0.663 Vel. 0.335 G.H. 7.47 Disch. 0.27

Method No. secs. 16 G.H. change 0.01 in 1.50 hrs. Susp.

Method coef. 1.0 Hor. angle coef. 1.0 Susp. coef. 1.0 Meter No. 4583

Type of meter S.H. 8777 Date rated Tag checked

Meter 0.01 ft. above bottom of wt. Spin before meas. 1.20 after 1.00

Mess. plots % diff. from rating. Levels obtained

GAGE READINGS		WATER QUALITY MEASUREMENTS	
Time	Inside ADR	Graphic Outside	No. X. Yes. Time
3:25		7.47	
			Samples Collected
			No. Yes. Time
			Method Used
			EDI EWI Other
			No. X. Yes. Time
			Method Used
			EDI EWI Other
			No. X. Yes. Time
			BIOLOGICAL SAMPLES
			Yes. X. Time
			No. Time

Weighted M.G.H. 7.47

G. H. correction 7.47

Correct M.G.H. 7.47

Check bar chain found changed to 1.0 at 1.00

Wading cable, ice, boat, upstr., downstr., side bridge 1.0 feet - above, below - gage

Measurement rated excellent (25% good (5%)) fair (8%), poor (over 8%); based on the following cond:

Flow 500

Cross section 300

Control 5.000 - 2000 ft. sectional

Gage operating Weather Cond. 147.45

Intake/Orifice cleaned Air 15.9 °C @ 1403

Record removed Extreme Indicator: Max. Min. per min.

Manometer N<sub>1</sub> Pressure Tank Feed Blbl rate

CSG checked Stick reading

Observer

HWM

Remarks Est. RP of top of orange painted edge of upstream center outside, in well

of head wall, E. 100 = 9.99 ft. 9.99 - 2.57 = 7.42

C.H. of zero flow ft. Sheet No. of sheets

Discharge	Area	Adjusted angle or	Area	Discharge
0.015	0.015		0.015	0.007
0.034	0.034		0.036	0.016
0.036	0.036		0.036	0.019
0.036	0.036		0.036	0.017
0.036	0.036		0.036	0.018
0.036	0.036		0.036	0.010
0.040	0.040		0.040	0.008
0.040	0.040		0.040	0
0.048	0.048		0.048	0.015
0.056	0.056		0.056	0.022
0.056	0.056		0.056	0.022
0.058	0.058		0.058	0.020
0.058	0.058		0.058	0.021
0.063	0.063		0.063	0.009
0.019	0.019		0.019	0
Total				0.222

Appendix 6b. Discharge measurement field sheet from Herring River near Wellfleet, MA, September 2000.



STANDARD RATING TABLE NO. 2 FOR PYGMY CURRENT METER (6/99)  
 EQUATION:  $V = 0.9604 R + 0.0312$  (R=revolutions per second)

Seconds	VELOCITY IN FEET PER SECOND														
	Revolutions														
	3	5	7	10	15	20	25	30	40	50	60	80	100	150	200
40	0.103	0.151	0.199	0.271	0.391	0.511	0.631	0.752	0.992	1.23	1.47	1.95	2.43	3.63	4.83
41	0.101	0.148	0.195	0.265	0.383	0.500	0.617	0.734	0.968	1.20	1.44	1.91	2.37	3.54	4.72
42	0.100	0.146	0.191	0.260	0.374	0.489	0.603	0.717	0.946	1.17	1.40	1.86	2.32	3.46	4.60
43	0.098	0.143	0.188	0.255	0.366	0.478	0.590	0.701	0.925	1.15	1.37	1.82	2.26	3.38	4.50
44	0.097	0.140	0.184	0.249	0.359	0.468	0.577	0.686	0.904	1.12	1.34	1.78	2.21	3.31	4.40
45	0.095	0.138	0.181	0.245	0.351	0.458	0.565	0.671	0.885	1.10	1.31	1.74	2.17	3.23	4.30
46	0.094	0.136	0.177	0.240	0.344	0.449	0.553	0.658	0.866	1.08	1.28	1.70	2.12	3.16	4.21
47	0.093	0.133	0.174	0.236	0.338	0.440	0.542	0.644	0.849	1.05	1.26	1.67	2.07	3.10	4.12
48	0.091	0.131	0.171	0.231	0.331	0.431	0.531	0.631	0.832	1.03	1.23	1.63	2.03	3.03	4.03
49	0.090	0.129	0.168	0.227	0.325	0.423	0.521	0.619	0.815	1.01	1.21	1.60	1.99	2.97	3.95
50	0.089	0.127	0.166	0.223	0.319	0.415	0.511	0.607	0.800	0.992	1.18	1.57	1.95	2.91	3.87
51	0.088	0.125	0.163	0.220	0.314	0.408	0.502	0.596	0.784	0.973	1.16	1.54	1.91	2.86	3.80
52	0.087	0.124	0.160	0.216	0.308	0.401	0.493	0.585	0.770	0.955	1.14	1.51	1.88	2.80	3.73
53	0.086	0.122	0.158	0.212	0.303	0.394	0.484	0.575	0.756	0.937	1.12	1.48	1.84	2.75	3.66
54	0.085	0.120	0.156	0.209	0.298	0.387	0.476	0.565	0.743	0.920	1.10	1.45	1.81	2.70	3.59
55	0.084	0.119	0.153	0.206	0.293	0.380	0.468	0.555	0.730	0.904	1.08	1.43	1.78	2.65	3.52
56	0.083	0.117	0.151	0.203	0.288	0.374	0.460	0.546	0.717	0.889	1.06	1.40	1.75	2.60	3.46
57	0.082	0.115	0.149	0.200	0.284	0.368	0.452	0.537	0.705	0.874	1.04	1.38	1.72	2.56	3.40
58	0.081	0.114	0.147	0.197	0.280	0.362	0.445	0.528	0.694	0.859	1.02	1.36	1.69	2.51	3.34
59	0.080	0.113	0.145	0.194	0.275	0.357	0.438	0.520	0.682	0.845	1.01	1.33	1.66	2.47	3.29
60	0.079	0.111	0.143	0.191	0.271	0.351	0.431	0.511	0.671	0.832	0.992	1.31	1.63	2.43	3.23
61	0.078	0.110	0.141	0.189	0.267	0.346	0.425	0.504	0.661	0.818	0.976	1.29	1.61	2.39	3.18
62	0.078	0.109	0.140	0.186	0.264	0.341	0.418	0.496	0.651	0.806	0.961	1.27	1.58	2.35	3.13
63	0.077	0.107	0.138	0.184	0.260	0.336	0.412	0.489	0.641	0.793	0.946	1.25	1.56	2.32	3.08
64	0.076	0.106	0.136	0.181	0.256	0.331	0.406	0.481	0.631	0.782	0.932	1.23	1.53	2.28	3.03
65	0.076	0.105	0.135	0.179	0.253	0.327	0.401	0.474	0.622	0.770	0.918	1.21	1.51	2.25	2.99
66	0.075	0.104	0.133	0.177	0.249	0.322	0.395	0.468	0.613	0.759	0.904	1.20	1.49	2.21	2.94
67	0.074	0.103	0.132	0.175	0.246	0.318	0.390	0.461	0.605	0.748	0.891	1.18	1.46	2.18	2.90
68	0.074	0.102	0.130	0.172	0.243	0.314	0.384	0.455	0.596	0.737	0.879	1.16	1.44	2.15	2.86
69	0.073	0.101	0.129	0.170	0.240	0.310	0.379	0.449	0.588	0.727	0.866	1.14	1.42	2.12	2.81
70	0.072	0.100	0.127	0.168	0.237	0.306	0.374	0.443	0.580	0.717	0.854	1.13	1.40	2.09	2.78
	3	5	7	10	15	20	25	30	40	50	60	80	100	150	200

Appendix 8. Standard rating table No. 2 for Pygmy current meters (USGS, 1999b)

**APPENDIX B**  
**STREAM FLOW MONITORING**  
**DATA SHEETS 1-3**

**DATA SHEET #1: STREAM FLOW GAGING STATION: SITE SELECTION**

Rate the location of the stream flow gaging station for each of these features

Station Name:

GPS Coordinates

**Confined Channel Location**

**Alluvial Channel Location**

<b>Rating</b>	<b>Characteristic</b>	<b>Notes, description</b>
H M L	Perennial	
H M L	Artificial structure (bridge, dam, weir or flume)	
H M L	Straight channel ~300 ft upstream and downstream of site	
H M L	Limited scour, deposition, algal growth	
H M L	Low loss to groundwater	
H M L	No secondary channel	
H M L	Permanent banks high enough to contain floods, brush-free	
H M L	Persistent pool upstream of site (how far?)	
H M L	Upstream of a confluence (how far?)	
H M L	Good for measuring discharge at all stages (how far from site?)	
H M L	Accessible and safe	
H M L	Streambed characteristics (stable, even, not soft)	
<b>H M L</b>	<b>OVERALL</b>	

Assessment of site, advantages, disadvantages

**DATA SHEET #2: STREAM FLOW GAGING STATION: DISCHARGE SITE**

**Rate the location of the discharge measurement for each of these features**

<i>rating</i>	<i>criteria</i>	<i>notes, description</i>
H M L	Perennial flow	
H M L	Artificial structure (bridge, dam, weir or flume)*	
H M L	Stable cross section*	
H M L	Straight channel ~100 ft upstream and downstream of measurement site	
H M L	Little slope change	
H M L	Velocity threads are parallel	
H M L	Uniform current at measurement site free of eddies, side currents and dead water	
H M L	Little water turbulence at measurement site	
H M L	Flow has primarily downstream current uninterrupted by rocks of different sizes or vegetation	
H M L	<b>OVERALL</b>	
	*Describe grade control at measurement site below including if rocks in channel were rearranged to improve measurement	
	Take a photo of the site where the discharge measurement was done and record a GPS point	

Assessment of site, advantages, disadvantages, affect on discharge measurements

**DATA SHEET #3: STREAMFLOW GAGING: STAGE-DISCHARGE MEASUREMENT**

PAGE 1

Date

Field Team

Weather conditions

Stream observations

Flow conditions

Current meter instrument number and model:

Was spin test completed prior to measurement

**CURRENT METER READINGS**

Start time

Water level

Staff gage:

Velocity readings

Distance from reference point feet	Panel number	Panel width	Time hh:mm	Water depth feet	Velocity readings				Panel discharge cfs	Notes
					20% depth fps	60% depth fps	80% depth fps	Mean velocity fps		
	1									
	2									
	3									
	4									
	5									
	6									
	7									
	8									
	9									
	10									
	11									
	12									
	13									
	14									
	15									
	16									

**COMPLETE ON PAGE 2**



**CURRENT METER READINGS CONT.**

Distance from reference point feet	Panel number	Panel width	Time hh:mm	Water depth feet	Velocity readings				Panel discharge cfs	Notes
					20% depth fps	60% depth fps	80% depth fps	Mean velocity fps		
	17									
	18									
	19									
	20									
	21									
	22									
	23									
	24									
	25									
	26									
	27									
	28									
	29									
	30									

Total of panel discharges

cfs

Stop time

Water level

Staff gage: